

bühler

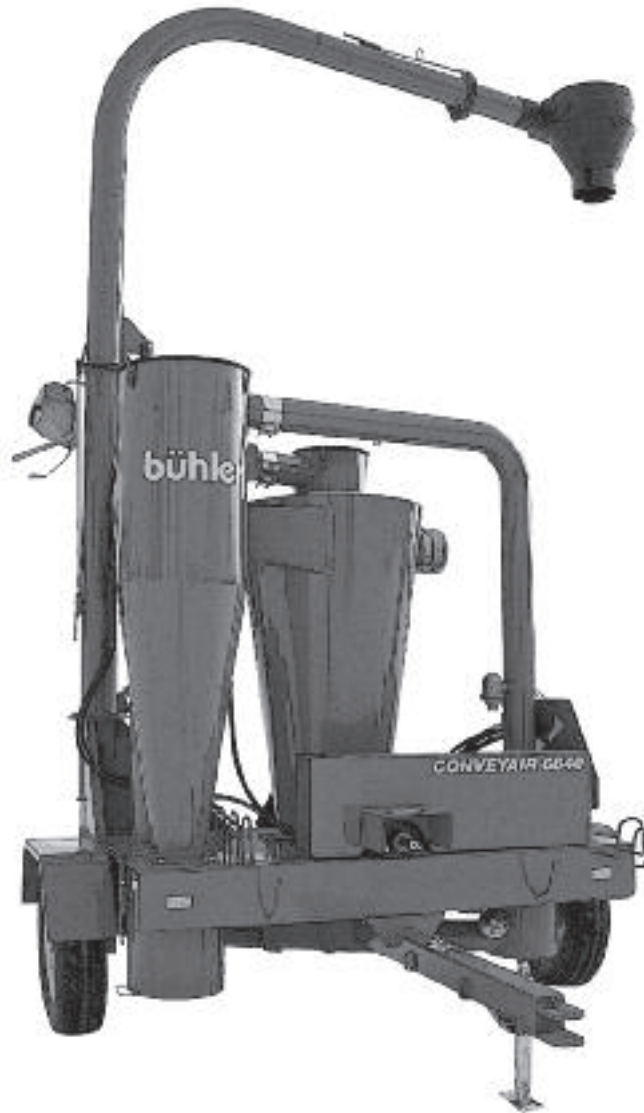

Conveyair Grain Vac 6640

Operator's and Parts Manual
FK376

2009

Introduction

Congratulations, you have selected a Buhler Conveyair Grain Vac which is designed and engineered to help you make farming Easier, Healthier and Safer.

Our knowledgeable engineering and production staff have built both performance and durability into each Buhler Conveyair. Our grain vacs have been sold to farmers in Canada, Europe, the USA, Australia and the Middle East.

To get the maximum benefit from your Buhler Conveyair please read the owner's manual carefully.

How to use this manual

We recommend that you study this manual from beginning to end BEFORE operating your new Buhler Conveyair Grain Vac. We have tried to keep it brief and to the point. It is important that you pay special attention to the safety cautions in this book and on your equipment.



Safety Warnings and Symbols



As with all farm equipment, it is extremely important that you familiarize yourself with all the safety precautions and follow them wisely.

Words like CAUTION or DANGER will tell you about things that could hurt you if you were to ignore the warning!



This safety symbol means:

“Don’t”
“Don’t do this” or
“Don’t let it happen”

Index Page

Introduction	Inside Front Cover
Warranty Registration	-
Sign-off Form	-
Serial # Registration	4
Specifications	4
Safety Precautions	6-9
Transport	10
Setting Up	11-14
Break In	14
Operation	15-18
(a) Short Distance	16
(b) Long Distance	17
(c) Top Loading	17
(d) Clean Up	17
(e) Bins and Storage	18
Accessories	19
Lubrication	20-21
Service Record	22
Service and Maintenance	23-27
Torque Charts	28
Hydraulic Schematics	29-30
Trouble Shooting	31-34
Storage	35
Parts Manual	37-49
Warranty	Inside Back Cover

Serial Numbers

When you order parts or require service, provide your dealer with complete **PARTS, MODEL & SERIAL NUMBER(S)!**

You will find **TWO** serial numbers on your unit, we suggest you enter these in your manual now for quick reference later:



LOCATIONS

- 1. Machine Serial number -**
Look at rear of machine, right side
- 2. Blower Serial number -**
Look at front of machine at side of blower facing receiver tank

.....
Machine Serial Number

.....
Blower Serial Number

Specifications

Minimum Horse Power (1000 PTO RPM)	110
Length	2.43 m (96")
Width	2.36 m (93")
Height (transport)	2.54 m (100")
Clearance (under cyclone)	3.50 m (138")
Weight (complete with accessories)	1204 Kg (2650 lb)
Tire size	6.70 x 15 (8 ply)
Tire Pressure	35 PSI

SPECIFICATIONS ARE SUBJECT TO CHANGE WITHOUT NOTICE



Read and understand the operation manual before operating the Conveyair. Always follow safety and operating instructions as outlined in this manual. Familiarize yourself with the terms shown on this page.

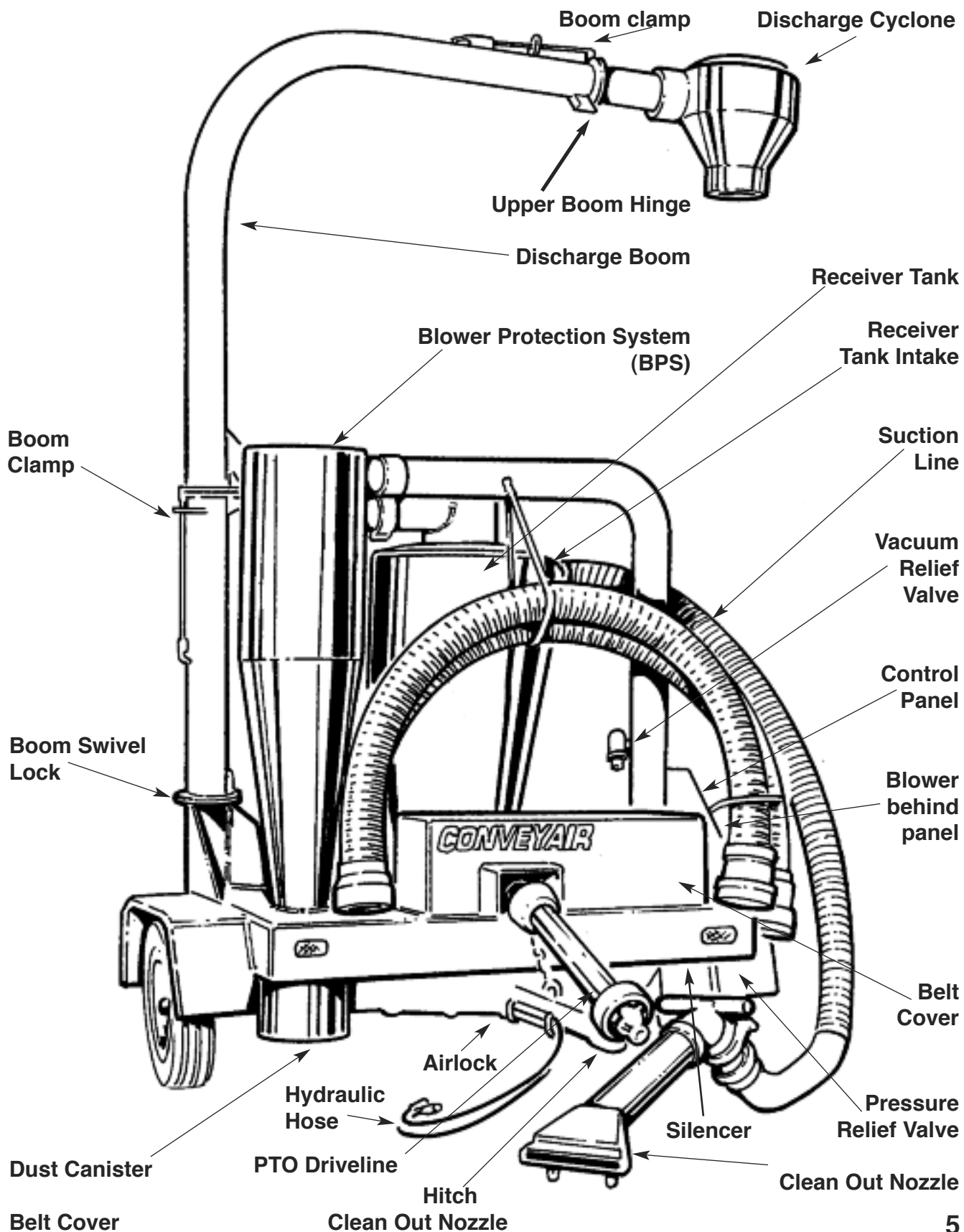

Safety Precautions

Buhler Industries is concerned about your safety and is committed to the prevention of accidents. SAFE AND CORRECT USE of this equipment will help prevent accidents. **Be sure anyone who operates the Buhler Conveyair Grain Vac has read and understood this manual! BEFORE operating, maintaining, adjusting or unplugging the grain vac.** Review at least annually as per OSHA (Occupational Safety and Health Administration) regulations 1928.57

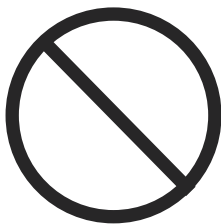

Do not modify the equipment in any way. Unauthorized modifications may impair the function and/or safety and could affect the life of the equipment.

SAFETY WARNINGS AND SYMBOLS



**This Safety Alert symbol means -
ATTENTION!
BE ALERT!
YOUR SAFETY IS INVOLVED!**

**Watch out for this symbol on
your Buhler Conveyair Grain Vac and
throughout the manual**

SIGNAL WORDS:

DANGER - An immediate and specific hazard which **WILL** result in severe personal injury or death if the proper precautions are not taken.

WARNING - A specific hazard or unsafe practice which **COULD** result in severe personal injury or death if proper precautions are not taken.

CAUTION - Unsafe practices **COULD** result in personal injury if proper practices are not taken, or as a reminder of good safety practices.



Operating Safety



1. Wear appropriate ear protection.
2. Never wear ill-fitting, baggy or frayed clothing when working around or on any of the drive system components.
3. Always know where all overhead electrical wires are located and stay away from them.
4. Do not allow riders.
5. Install and secure all guards and shields before starting or operating.
6. Keep hands, feet, hair and clothing away from moving parts.
7. Place all controls in neutral, stop tractor engine, set park brake, remove ignition key and wait for all moving parts to stop before servicing, adjusting, repairing or unplugging.
8. Place all tractor and machine controls in neutral before starting.
9. Never operate the Conveyair and power unit inside a closed building.
10. Clear area of bystanders, especially small children, before starting.
11. Stay away from PTO shaft, intake nozzle and discharge when engaging PTO.
12. Keep all hydraulic lines, fittings and couplers tight and free of leaks.
13. Clean reflector, SMV and lights before transporting.
14. Use proper lighting when transporting.
15. Use a retainer or drawbar pin, secure PTO shaft and install a safety chain when attaching to tractor.
16. Stay away from overhead electrical wires when operating boom or when moving.
17. Do not remove receiver inspection window while tractor is running.
18. Do not remove elbow from airlock outlet when tractor is running.
19. Stay clear of truck loading boom when folding it.
20. Review safety instructions with all operators annually.

Safety Precautions

SAFETY DECAL LOCATIONS

Decals with “CAUTION”, “ DANGER”, “WARNING”, and other information appear on your machine for your safety. Read the information carefully and replace the decals that are no longer legible.

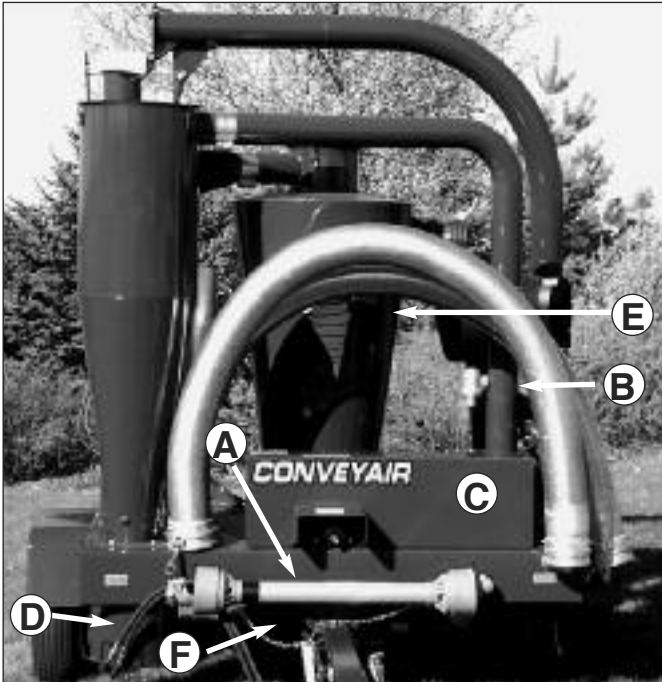



DANGER



ROTATING DRIVELINE HAZARD

To prevent serious injury or death from rotating driveline:

- Keep all guards in place when operating.
- Operate only at 1000 RPM.
- Keep hands, feet, hair and clothing away

Shield & Shaft “A”



CAUTION

- Read and understand the Operator’s Manual before starting and operating.
- Never operate the machine inside a closed building.
- Install and secure all shields before operating.
- Clear the area of people, especially small children, and the machine of foreign objects before using.
- Keep hands, feet, clothing and hair away from moving parts and inlet nozzle.
- Place all controls in neutral, stop engine, remove key and wait for all moving parts to stop before servicing, lubricating, adjusting or unplugging.
- Watch for overhead electrical wires and obstructions. Electrocution can occur without direct contact.
- Never operate machine with hydraulic leaks.
- Secure hitch, fasten safety chain and connect lights before transporting.
- Wear suitable ear protection for prolonged exposure to excessive noise.
- Chock wheels and block hitch before operating.
- Review safety items with all operators annually.

68.040



DANGER

ELECTROCUTION HAZARD

To prevent serious injury from electrocution: Stay away from overhead electrical wires when operating the discharge boom. Electrocution can occur without direct contact.

68 056

Control Panel “B”

Safety Precautions

 WARNING	ROTATING PART HAZARD To prevent serious injury or death from rotating parts: 1. Close and secure guard before operating. 2. Shut-off engine and wait for moving parts to stop before opening to adjust, service, lubricate or unplug. 3. Keep hands, feet, clothing and hair away from moving parts.
--	---

Guard "C"

CAUTION

**EMPTY DUST CANISTER
FREQUENTLY
AS PER OPERATORS MANUAL**

Dust Canister "D"



Dust Canister "D"

 WARNING	ROTATING AIRLOCK HAZARD To prevent serious injury or death from airlock blades: 1. Do not place hands in tank when airlock is turning. 2. Shut-off engine and wait for moving parts to stop before opening door to adjust, service or unplug.
---	---

Receiver Tank "E"

 WARNING	ROTATING AIRLOCK HAZARD To prevent serious injury or death from airlock blades: 1. Do not place hands in tank when airlock is turning. 2. Shut-off engine and wait for moving parts to stop before opening door to adjust, service or unplug.
--	---

Back Frame "F"



"F" Airlock behind frame

 **WARNING**

Do not place intake tube near feet when standing on top of grain. Sufficient material can be removed to draw the operator and intake tube into the grain. Submersion in grain can cause suffocation.

Bin Nozzle "G"



Bin Nozzle "G"

Transport

The Buhler Conveyair Grain Vac is designed to be easily moved from location to location. When transporting, follow this procedure:



TRANSPORT SAFETY

1. Make sure you are in compliance with all local regulations regarding transporting equipment on public roads and highways.
2. Make sure the SMV(Slow Moving Vehicle) emblem and all the lights and reflectors that are required by the local highway and transport authorities are in place, are clean and can be seen clearly by all overtaking and oncoming traffic.
3. Do not allow anyone to ride on the grain vac or tractor during transport.
4. Do not exceed 32 km/h (20 mph). Reduce speed on rough roads and surfaces.
5. Use a retainer on the drawbar pin and install a safety chain before transporting.
6. Always use proper lighting on the tractor when transporting.
7. Stay away from overhead electrical wires. Electrocutation can occur without direct contact.

8. When using a ball and socket, make sure the locking jaws are pinned securely in position.

9. Make sure all components and accessories are retracted and securely stowed before moving.

Speed VS Weight Ratio

Road Speed	Weight of fully equipped or loaded implement(s) relative to weight of towing machine.
Up to 32 km/h (20 mph)	1 to 1, or less
Up to 16 km/h (10 mph)	2 to 1, or less
Do not tow	More than 2 to 1

EQUIPMENT MATCHING

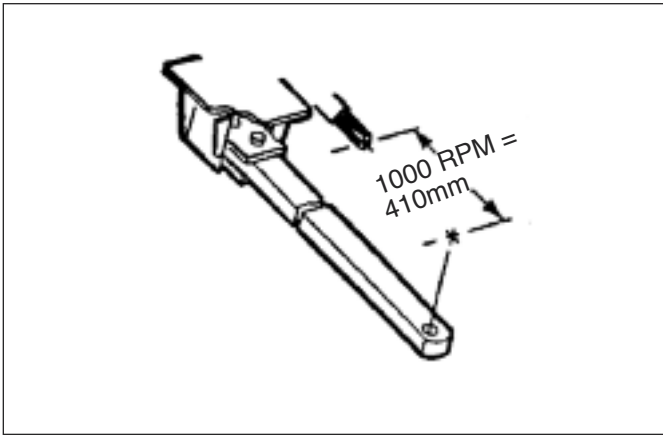

Drawbar

To provide sufficient clearance for turning and to allow telescoping of the shaft, leave 410mm between the end of the shaft and drawbar pin-hole centre. Consult your tractor manual for the drawbar adjustment procedure.

Tractor Horsepower (PTO RPM -1000)

Minimum Horsepower: 110

PTO Shaft

1000 RPM - 21 Spline. 35cm.

Attach PTO shield safety chain to hitch.

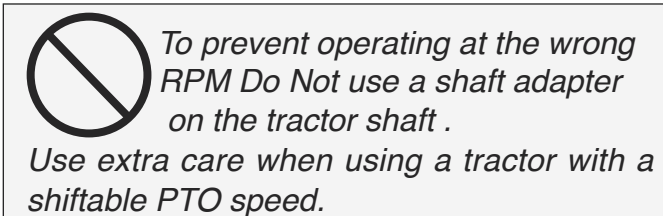

To prevent operating at the wrong RPM Do Not use a shaft adapter on the tractor shaft .

Use extra care when using a tractor with a shiftable PTO speed.

Hydraulic System

The power unit must have dual remote hydraulic outlets to operate the airlock motor and the boom lift circuit. The system must deliver at least 6 gpm (23 lpm) @ 1800 PSI.

ATTACHING TRACTOR

Drawbar

1. Clear area of bystanders.
2. Use the jack on the hitch to adjust the height

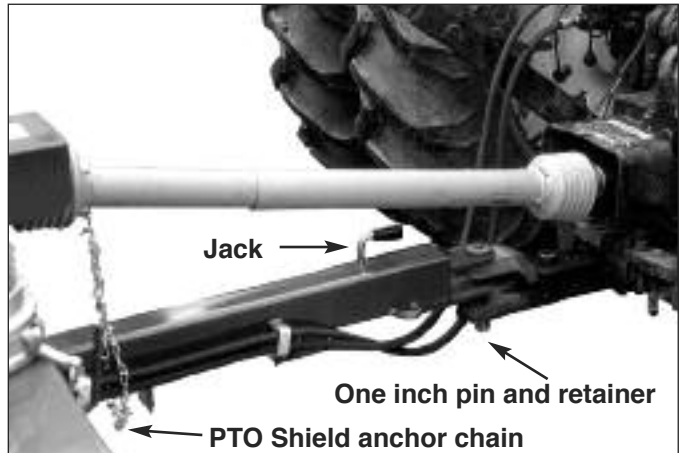

of the hitch to the drawbar.

3. Slowly back up to the machine and align the drawbar with the hitch.
4. Place all controls in neutral, stop tractor engine, set the park brake, remove ignition key and wait for all moving parts to stop before dismounting.
5. Insert a 1 inch (25 mm) hardened drawbar pin and install a retainer such as a Klik pin.
6. Attach a safety chain between tractor and Grain Vac.

Getting Ready

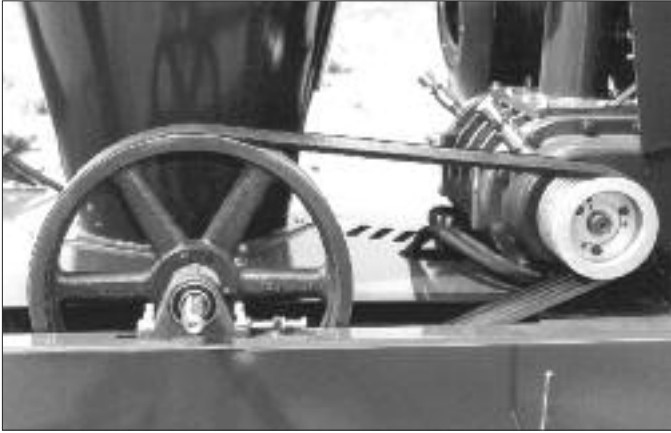

7. Open the belt cover and rotate the large pulley by hand to be sure the air pump turns freely.



Machine is shown with guard open for illustrative purposes only! Do not operate the machine with guard open.

Attach PTO Shaft

1. Clean splined yokes on the driveshaft.
2. Check that the driveshaft telescopes easily and that the shield turns freely on the shaft. Lubricate or clean before attaching if it does not move freely.
3. Pull back locking collar on the yoke and slide the yoke over the splined shaft of the large pulley. Rotate the pulley by hand as needed to align the splines of the yoke and the shaft.
4. Be sure the locking pin clicks into its locking groove on the shaft.
5. Attach the shield anchor chain to the frame.
6. **Close and secure the belt cover.**

Attach Hydraulic Lines

1. Clean hydraulic couplers and male tips. (Buhler factory supplied male tips are Standard 150 Tips).
2. Route the hydraulic hoses along the hitch and away from moving parts. Secure in position with clips or ties. (Be sure hoses are not pinched or crimped).

BPS and Receiver Tank Screens

Before moving grain or other materials ensure both BPS screen and main receiver tank screen are installed in machine properly at all times. (see: location on drawing, page 13)

Oil Level

Check the oil level in the blower reservoir. Add correct oil as required.

Position Boom

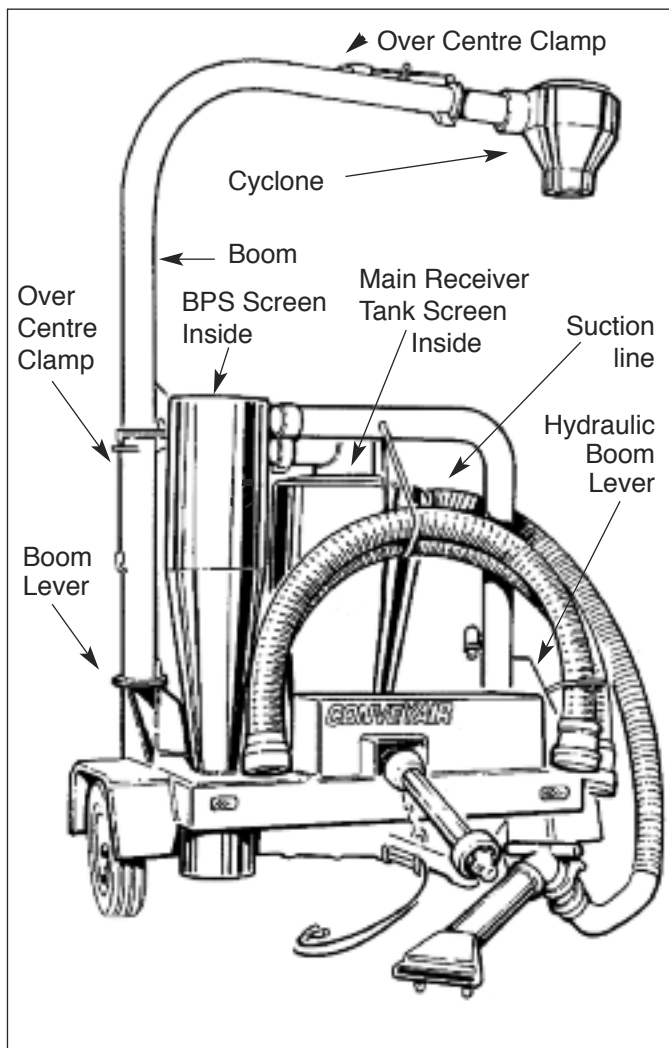

Boom Swivel

Boom Swivel

1. Set the park brake and run the tractor at low idle engine RPM. Place all controls in neutral. Place chocks ahead and behind rear tires to prevent machine movement when operating.
2. Use the control lever in the cab to engage the remote hydraulic circuit.
3. Unlatch boom transport clamp, flip up the boom lock, and swing boom back until it clears the transport step.



All bystanders should stay well clear of boom when raising or lowering it!!

Getting Ready



DANGER

Stay at least 15 feet (5 m) away from overhead power lines when moving the boom. Electrocutation can occur without direct contact.

4. Use hydraulic boom lever (Up to raise, down to lower). Carefully raise boom high enough to allow cyclone assembly (at end of boom) to swivel into position.
5. Secure cyclone into position, using over-center clamp.
6. Now lift boom all the way into working position.
7. Secure boom with Over Centre Clamp.
8. Attach suction line to the receiver tank intake coupler. Close camlock couplers.
9. Flip transport step up during operation of Conveyair.

Getting Ready

Airlock Rotation



Do not run the airlock in the reverse direction. Damage may occur to the hydraulic motor.



Check the rotation of the airlock. Coupler should turn as indicated by arrow.

If airlock rotates in wrong direction, stop and reverse direction of control lever on the tractor, or shut down the hydraulic system and reverse the order of the hoses plugged into the tractor couplers.

For Best Performance

1. Working area should be reasonably level and dry.
2. The tractor should be positioned to have the driveline angles at a minimum.
3. The Buhler Conveyair should be located so the intake line is as straight and as short as possible.
4. When using the Buhler Conveyair to load trucks, make sure there is adequate room for the receiving vehicle to get under the discharge cyclone.

Breaking In

Your machine has been operated for a short time at the factory to assure good performance. It can however not be considered broken in. It normally takes 5 to 10 hours of operation for all parts to be polished by the grain stream and for the machine to come up to full capacity.

We recommend the following checks during the break in period:

A. After operating for 1/2 hour -

1. Check for overheated bearing. Lubricate or adjust as required*.
2. Check for oil leaks. Tighten or replace part and oil as required*



WARNING

High pressure fluids can penetrate the skin and cause infection and toxic reaction.

3. Retorque all hardware - Wheel bolts and fasteners.
4. Check belt tension and adjust as required*.
5. Check the oil levels in the blower reservoirs. If low, add oil as required. Check for leaks and correct if problem persists*.

** Check maintenance section for proper procedures. (**Also see page 27 for hydraulic safety**)*

B. After operating for 2 to 10 hours -

1. Perform the same checks and inspections as done at 1/2 hour.
2. After the 10 hour inspection, go to normal service and maintenance procedures.

1. Set Airlock Speed

For maximum performance adjust speed most suitable for material moved.

Material	Airlock Speed (RPM)
Barley	50 - 60
Canola	45 - 60
Corn	45 - 60
Flax	35 - 55
Wheat	45 - 60
Oats	45 - 60

Material consistency varies widely in the field. Airlock speed is also affected by suction and discharge length. To obtain maximum performance, try different airlock speed, using above guide.

A rule of thumb is the larger and heavier the kernel, the faster the airlock should turn.

Tip - with light oats, or other light grains, slow PTO speed down to 900 or 950 RPM.



Adjusting Speed

Using a stop watch, the airlock can be set by counting the number of turns the coupler makes. Coupler is visible through the three slots in the deck of the machine. One turn per second equals 60 RPM.

Adjust airlock RPM by moving the airlock speed lever on your control panel towards # 10 to increase speed, toward # 1 to slow down. Move lever slowly, a small movement will make a significant change in airlock speed.

Operation

SHORT DISTANCE TRANSFER



Insert bin nozzle.

Connect hose from receiver intake to bin nozzle. Set the air slide on the full bin nozzle all the way open and push the nozzle into the material to be moved.



The line of the grain can be horizontal, angled or vertical depending on conditions.

Adjust the airslide on the full bin nozzle so that the material moves across the **sight glass window** of the receiver tank to approximately half way (no more than 2/3) up the window. If the machine starts to surge, slowly open slide till surging stops.

IMPORTANT

Note: Should the material stop moving and completely cover the sight glass window in the receiver tank, the machine will quickly plug. Immediately open the air slide fully, on the full bin nozzle, to allow the machine to clear itself. Remove the nozzle from the grain and forward and reverse the airlock several times to empty the tank. Then ensure the airlock is turning counter clockwise and resume operation as normal. Otherwise follow the next 6 steps:

IMPORTANT

If the machine still does not clear itself do the following:

- Stop machine** by slowly reducing tractor RPM to an idle, then disengage PTO. Remove dust pail which will allow any material in the bottom of Blower Protection Cyclone to run out.
- Remove nozzle from grain source
- Start the machine and allow the Receiver tank to empty itself. Then stop machine again
- Remove the top on the Blower Protection Cyclone and clean out any material in the top of the cyclone and in the pipe between the receiver tank and the Blower Protection Cyclone.
- Replace the Dust pail and the Top on the Blower Protection Cyclone.
- Start machine, (RECHECK AIRLOCK SPEED , page 15) and reset the air slide as per start up instructions.

Note: Airlock should not turn faster than 65 RPM or slower than 30 RPM.



LONG DISTANCE BLOWING



WARNING

Do not use P.V.C. or other plastic tubing for long distance application. The build-up of static electricity could lead to an explosion.

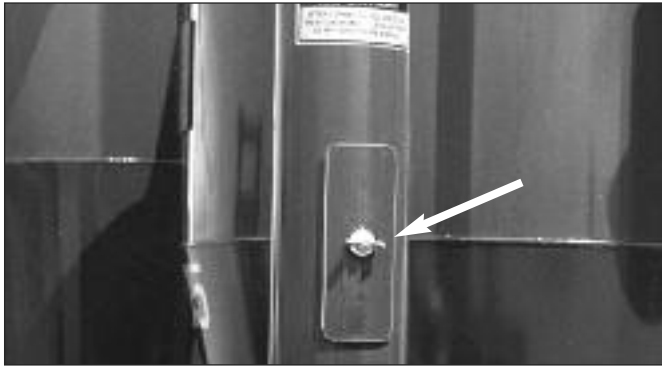

Auxiliary airslide. Located on the airline between the receiver tank and the air pump.

If discharge length is more than 40 ft. (12 m) or if blower gets too hot to the touch, open the airslide approximately 1/4" - 1/2" (6 - 12mm) for every 100 ft. (30 m) discharge. Open further if blower still gets hot.

Opening the airslide too far will affect capacity as adversely as not opening it at all.

TOP LOADING

(Push Only)

For top loading, remove top cover of large cyclone. To avoid feed back be sure grain enters below opening to BPS (smaller) cyclone.



LONG DISTANCE SUCTION

For sucking grain more than thirty feet, use straight piping where possible!

Remember: The straighter the suction line the greater the capacity of the Conveyair.

CLEAN UP

When machine need not be at full capacity, e.g. when cleaning bins, the tractor can be throttled down.



The rougher walls of the steel flex hose and the poly intake hose provide more resistance than smooth pipe. Capacity may be lowered by 20 to 40% compared to straight piping.

Use Poly hose for clean up only.



Do not dent, stretch or overbend steel flex line excessively.



Do not store poly hose in sunshine, avoid sharp obstructions that could cut or puncture the hose.

For regular cleanup use a combination of steel flex line, straight piping and poly hose. This will give you the needed flexibility to easily get into corners and around obstructions without sacrificing too much capacity.

SEED DRILL CLEAN OUT

When using the seed drill clean out kit, operate the tractor at idle only to reduce suction air flow. The receiver tank can be used as a holding tank by stopping the airlock until the seed can be discharged into a truck or storage.

Operation

CLEANUP OF SPILLS AND GROUND STORED GRAIN

Extreme caution should be exercised when cleaning spills or grain stored on dirt. Sand and dirt may cause excessive wear to blower, and life expectancy of the unit can be reduced significantly.

FILLING BINS AND TEMPORARY STORAGE



Rear discharge option required.

When discharging into bins, remove the airlock discharge elbow and couple the machine to stationary or movable piping.

For best performance, review recommended installation schematics. Use OEM parts to insure good sealing and maximum performance.

Contact your dealer for more information.

Silos over 100 feet tall can be filled with your CONVEYAIR!

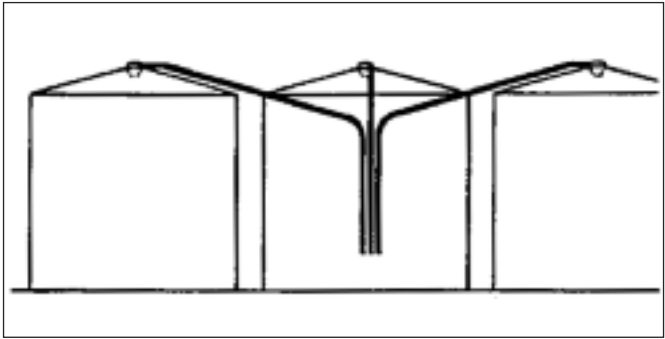

Multiple Bins (Parallel)

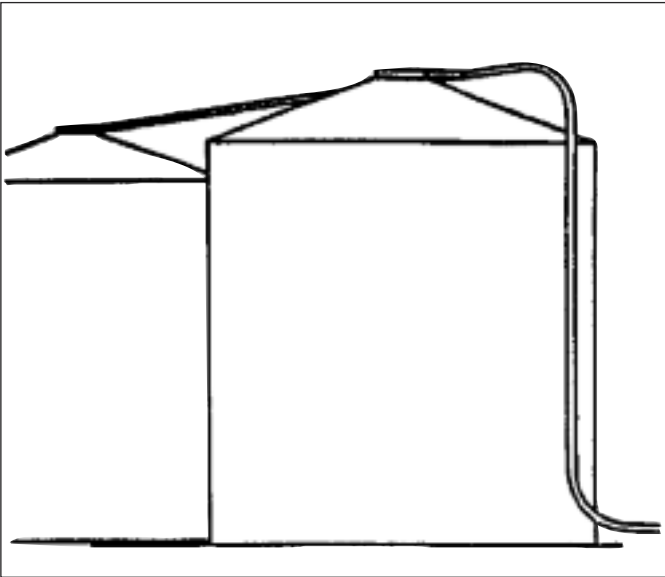

Multiple Bins (Series)

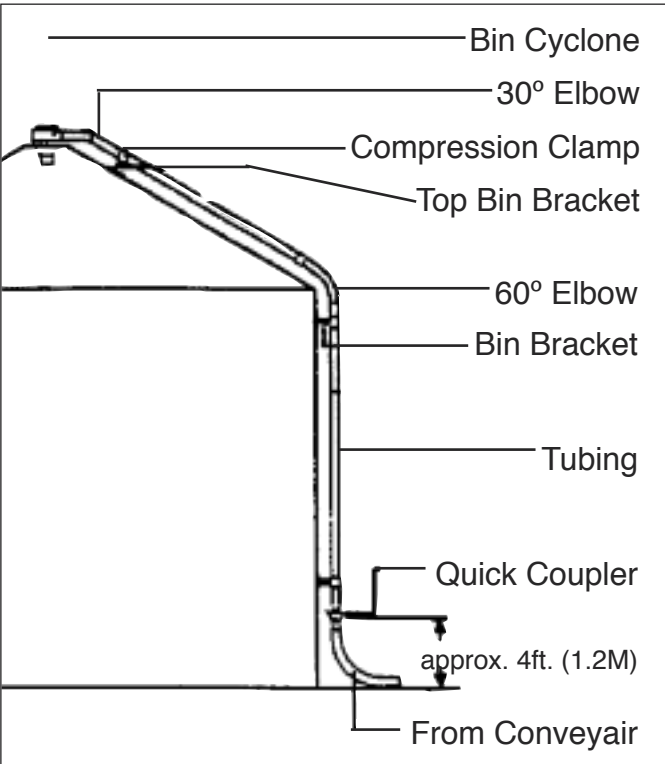

Bin Fill System

Accessories



Cam Lock Couplers



Cyclone sock for windy conditions



Seed Drill Cleanout Kit

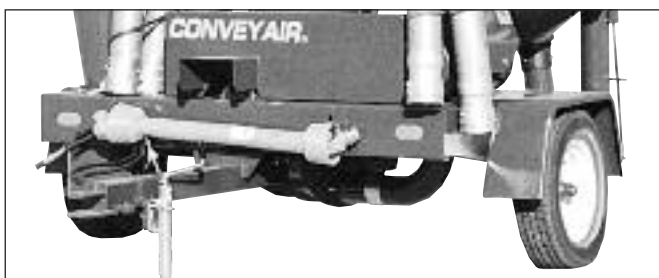

Fenders

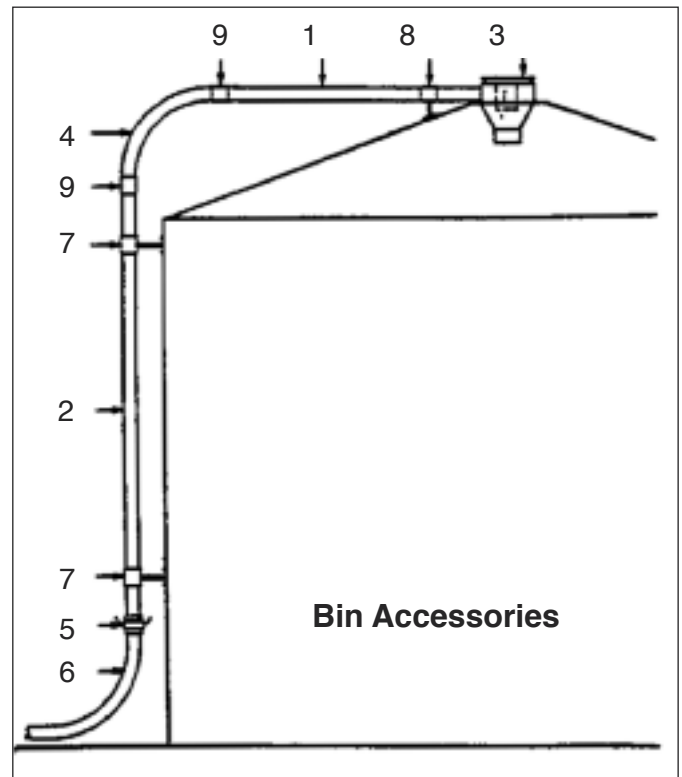

Bin Accessories

1. Horizontal Pipe Section.

Steel or aluminum. Matched to Buhler Conveyair Grain Vac.

2. Vertical Pipe Section. Specs as above. Sections may be welded or coupled together with 3-bolt clamp.

3. Bin Top Cyclone. Cyclones come equipped with a rain cap and can also double as aeration vents.

For temporary installations, use the lightweight poly cyclone and attach with quick couplers.

4. 90 Degree long radius elbow. Weld in place or secure with 3-bolt clamp.

5. 6" Female quick couplers.

6. Delivery from Buhler Conveyair to bin.

Use a combination of short stainless lined steel flex and long radius 90 degree elbow.

7. Side wall bin brackets.

8. Angle top mount bracket.

9. 3 Bolt clamp.

10. SEE PARTS LIST FOR STANDARD HOSE AND OTHER PARTS.

Lubrication

GREASING

Fluids and lubricants

Grease

Use any SAE multi -purpose high temperature grease with extreme pressure (EP) performances and containing at least 1.5% molybdenum disulfide or SAE Multi-Purpose Lithium Base Grease. Use cold temperature grease during the winter.

Oil

Only use **Blower Oil HD Synthetic Gear & Bearing Oil**. Do not blend with other oil. Available through your nearest Buhler Dealer. Part # **GV14220**

Capacity drive end 850 ml / 28.7 fl. oz US
Capacity gear end 1000 ml / 33.8 fl oz US

Hydraulic Oil Reservoirs: Self Contained Hyd.

AW32 Hydraulic oil equal to or exceeding SAE "SF" specifications.
Capacity - (31 qt. US)

Cleaning agent

WD40 or equivalent.

1. Use only a manual grease gun for all greasing. Air powered grease guns may damage the seal on bearings, leading to early bearing failure.



IMPORTANT

Do not over grease, it can damage bearing seals.

2. Wipe grease fitting with a clean cloth before greasing, to avoid injecting dirt and grit.
3. Replace and repair broken fittings immediately.

8 Hours or Daily

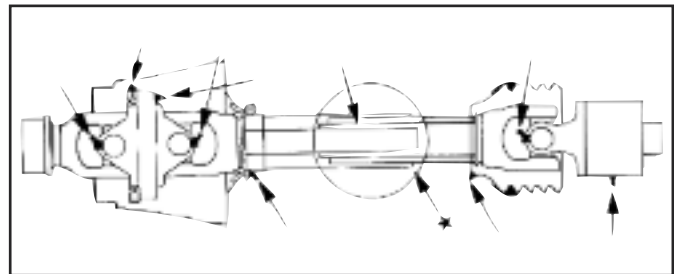

PTO SHAFT (9 Locations)

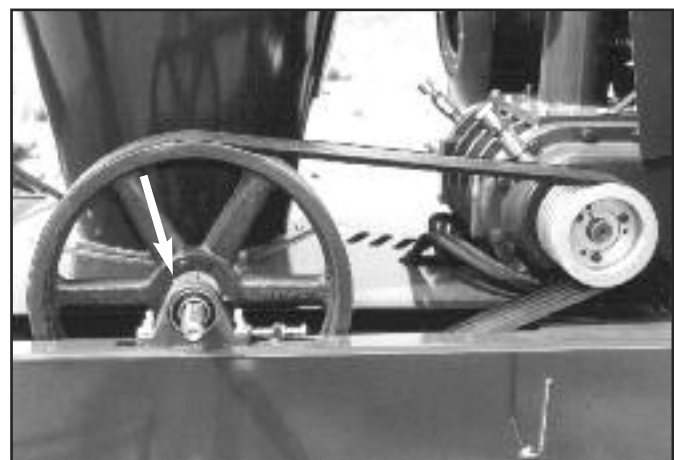

Input Pulley Shaft, front and rear



CAUTION

1. Place all controls in neutral, stop tractor engine, set park brake, remove ignition key and wait for all moving parts to stop before servicing.
2. Before applying pressure to a hydraulic system, make sure all lines, fittings and couplers are tight and in good condition.
3. Relieve pressure from hydraulic circuit before servicing or disconnecting from tractor.



CAUTION

Machine is shown with guard open for illustrative purposes only. Do not operate machine with guard open.

Lubrication

8 Hours or Daily



Check air pump oil levels in reservoirs, front and rear (2 locations). Add as required

NOTE

Check when the oil is cold and the machine is level.

100 Hours or 6 Months

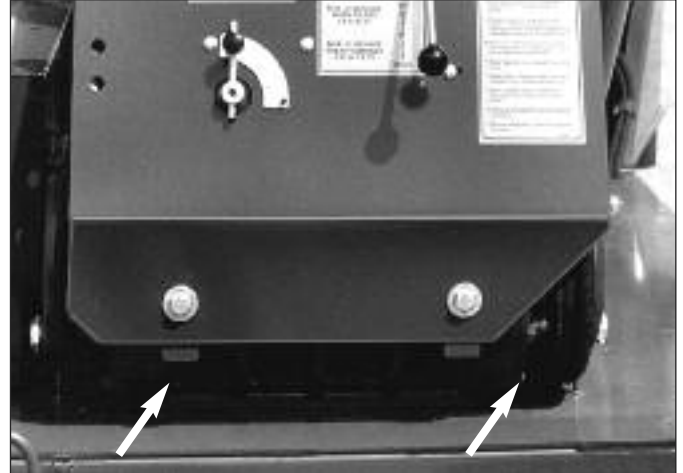

Change the oil in air pump reservoirs (front and rear).

NOTE

Change every 30 hours if operating in very dusty conditions

50 Hours

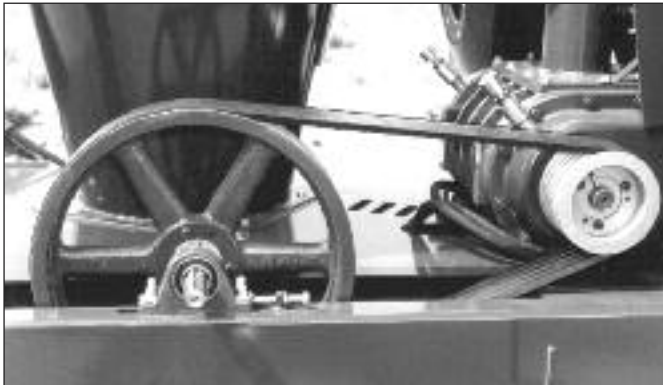

Clean oil reservoir breather caps (2 locations)

200 Hours or Annually



Repack wheel bearings (2 locations)

Grease as Required



Use winter friendly white lithium grease

**OBSERVE ALL SAFETY
PRECAUTIONS!**

V-BELT TENSION

5005 - force = 8 to 11 pounds
5006 - force = 8 to 11 pounds
6006 - force = 11 to 15 pounds

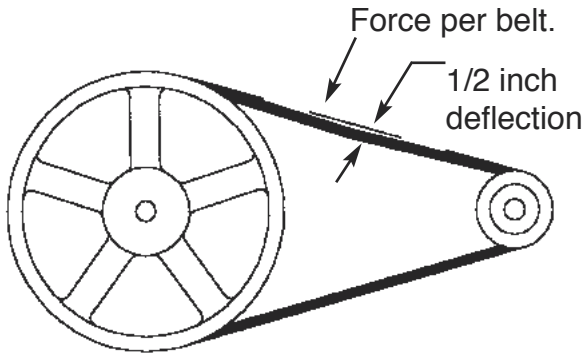

Check belt tension after initial one (1) to two (2) hours of operation and daily thereafter.

V Belt tension testers are available at most belt service centres.

1. Place PTO and hydraulic controls in neutral and shut-off engine. Disconnect the PTO shaft from the tractor.
2. Unlatch belt shield cover and open cover.

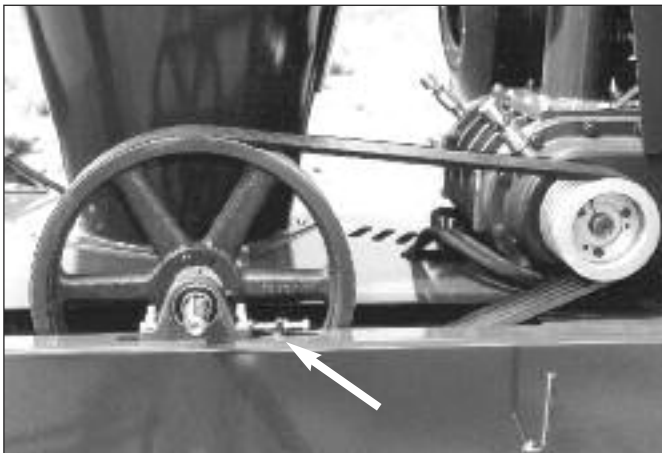

3. Loosen jam nut on adjuster bolts and loosen the bearing mounting bolts.

Maintenance

4. Use the adjusting bolts to move the pulley assembly to apply the proper tension to the belts and also to align the pulleys with each other.



CAUTION

Machine is shown with guard open for illustrative purposes only. Do not operate machine with guard open.

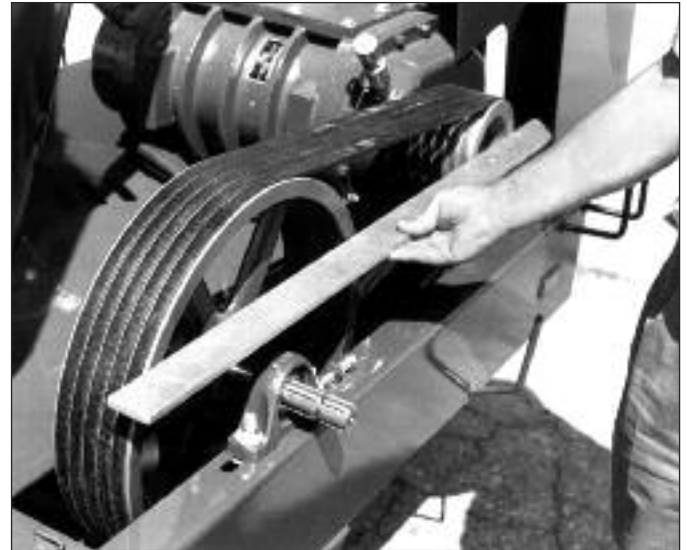

5. Place a straight edge across the faces of the two pulleys. Maximum allowable misalignment is 1/16" (2mm) on any of the pulley edges. Adjust as required.
6. Be sure the belt tension is correct.*
7. Tighten bearing mount bolts and jam nuts.
8. Close and latch belt cover.

*** DO NOT MIX OLD AND NEW BELTS!**

To extend the life of your bearings and shafts we recommend that you replace all 5 belts when one or more are frayed or broken. Older belts which have stretched over time require a different setting than new belts. To get the right tension on the old belts you will put too much tension on the new belt(s) putting undue strain on shafts and bearings!

Maintenance

AIRLOCK TIPS

Check Airlock Tips clearance when there is a noticeable drop in capacity of the Conveyair.

If clearance exceeds 0.015" (0.38mm) adjust as shown below.

a. Checking clearance:

Disengage PTO and hydraulic power and shut off engine. Wait for all moving parts to stop.

2. Relieve the pressure on the hydraulic lines and disconnect from tractor.

3. Remove hydraulic lines from the airlock drive motor to allow rotation of the airlock.



CAUTION

High pressure fluids can penetrate the skin and cause infection and toxic reaction.

4. Open the inspection door on the receiver tank. Use a feeler gauge to check the clearance between the tips and the shell.

b. Airlock Tip Adjustment

1. Remove the connector on the air line between the BPS and the receiver tank.

2. Attach an overhead hoist to the receiver tank.



3. Remove the eight bolts securing the receiver tank to the airlock mount plate. Remove the receiver tank from the frame.

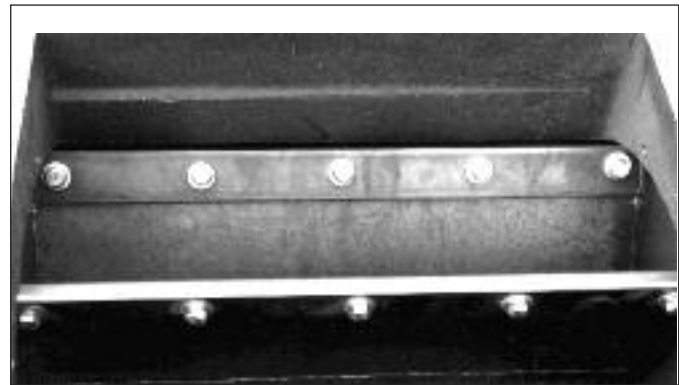

WARNING

ROTATING AIRLOCK HAZARD
To prevent serious injury or death from airlock blades:

1. Do not place hands in tank when airlock is turning.
2. Shut-off engine and wait for moving parts to stop before opening door to adjust, service or unplug.



4. Position tip next to top of shell.

5. Loosen slightly the 5 bolts attaching the tip to the blade of the airlock.

6. Move the tip until you have 0.006" (0.15 mm) clearance between tip end and clockwise side of shell.

7. Tighten the bolts and torque to 20-25 ft. lbs. (34-40 Nm).

8. Rotate the rotor clockwise to ensure that there is no contact between the tips, end plates and the shell. Adjust if there is contact.

9. Mark the tip with a felt pen as done and proceed with remaining tips till all have been adjusted.

10. Replace receiver tank and check that all connections are airtight.

Maintenance

RESERVOIR BREATHER

(Clean every 50 hours)

Clean breathers allow the pressure in the oil reservoir to equalize with the outside as the temperature changes.

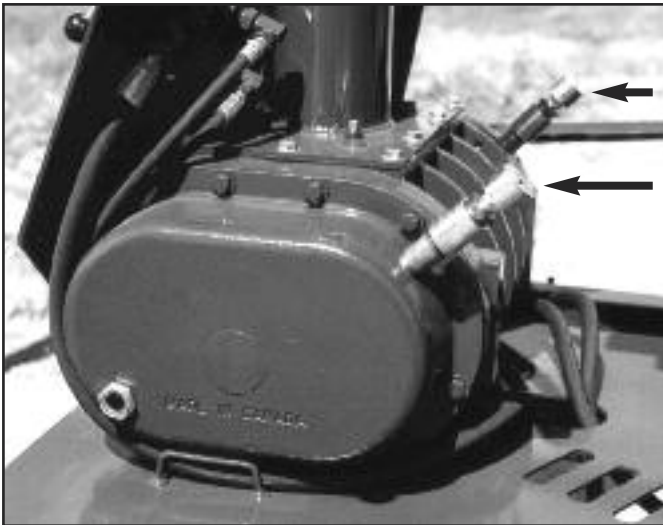

1. Remove breather from the top of the reservoirs.
2. Soak/wash in a good grade of solvent.
3. Dry with an airhose and re-install.

26042 Installation Instructions

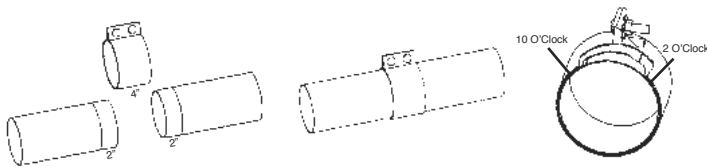

1. Remove burrs, dirt, grease from pipe ends.
2. Measure and mark both ends of the pipe at a distance that is half the length of the coupling.
3. Slide coupling over one pipe until it meets your mark, Insert next pipe section until pipes butt. Avoid disturbing gasket or inner sleeve.
4. Partially tighten 'CENTRE' bolt first, then uniformly alternate tightening all the bolts to 40 lbs. torque.
5. Tighten until top of flange is touching and there is approx. 3/16" of space at bottom of flange.
6. Make sure gasket joint and inner sleeve joint are at proper locations. (10 o'clock - 2 o'clock)

AIR PUMP OIL RESERVOIR

(Change oil every 100 hours, more often if conditions are very dusty).

1. Place small pan under the drain plug and remove plug. Drain for 10 minutes.
2. Re-install and tighten the drain plug.

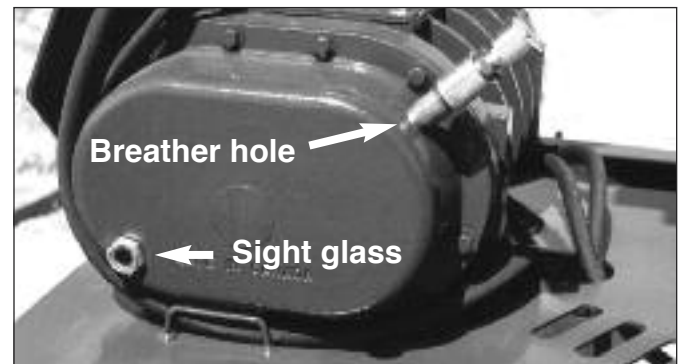

3. Remove breather and add oil through the breather hole. **Fill to center of the sight glass** and re-install breather.



IMPORTANT

- Overfilling causes heating from the oil churning.
- Underfilling causes heating from lack of lubrication.

4. Repeat on other reservoir.

Maintenance

BPS (Blower Protection System)

The air which is sucked from the receiver tank and drawn toward the air-pump contains dust which is harmful to the pump. This dust is trapped by the BPS system and collected in the dust canister. The amount of dust collected depends on the amount of dust and fines in the grain being moved.



Remove and empty dust canister regularly. Do not allow to overfill. When canister is three quarters full it should be considered full!

NOTE

If machine is allowed to overfill (plug) -

- Remove screen on top of BPS and clean if required and reinstall.



DO NOT strike the screen with any hard object as damage to the screen will diminish its effectiveness.

- Empty canister and also allow any grain which may have accumulated in BPS to run out.

Refer to unplugging instructions under OPERATION on page 16.

SHEAR PIN

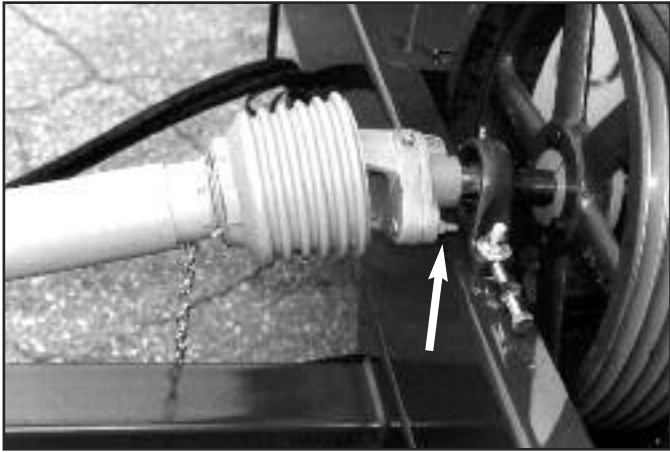

A shear pin is provided in the PTO shaft to protect the drive system during an overload.

Changing the Shear Pin

1. Place all controls in neutral, stop engine, set park brake, remove ignition key and wait for all moving parts to stop before dismounting.
2. Disconnect the PTO shaft from the tractor and lay to the side to provide maximum clearance for the shear bolt.
3. Carefully remove remaining shear bolt using a hammer and punch if necessary. Do not enlarge the holes.
4. Install the new shear bolt and tighten.



IMPORTANT

These shear bolts are specially designed to provide protection for the drive system. Do not install just any bolt, use genuine OEM parts.

HYDRAULIC SAFETY

1. Make sure that all components in the hydraulic system are kept in good condition.
2. Replace any worn, cut, abraded, flattened or crimped hoses and metal lines.
3. Before applying pressure to the system, make sure all components are tight and that lines, hoses and couplings are not damaged.



Do not use tape, clamps or cement to repair hydraulic lines. The hydraulic system operates under high pressure, creating a hazardous unsafe condition when such repairs fail suddenly.

4. Wear proper hand and eye protection when searching for a high pressure hydraulic leak. Use a piece of wood or cardboard as a backstop instead of hands to isolate and identify leak.



5. If injured by a concentrated high pressure stream of hydraulic fluid, seek attention immediately. Serious infection or toxic reaction can develop from hydraulic fluid piercing the skin surface.



WARNING

High pressure fluids can penetrate the skin and cause infection and toxic reaction.

Bolt Torque

Check tightness of bolts periodically, using bolt torque chart as a guide. Always replace hardware with the same strength bolt.

English Torque Specifications

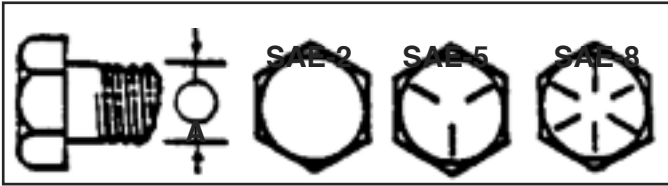

Bolt Dia. "A"	Bolt Torque*					
	SAE 2		SAE 5		SAE 8	
	N.m (lb-ft)		N.m (lb-ft)		N.m (lb-ft)	
1/4"	8	(6)	12	(9)	17	(12)
5/16"	13	(10)	25	(19)	36	(27)
3/8"	27	(20)	45	(33)	63	(45)
7/16"	41	(30)	72	(53)	100	(75)
1/2"	61	(45)	110	(80)	155	(115)
9/16"	95	(70)	155	(115)	220	(165)
5/8"	128	(95)	215	(160)	305	(220)
3/4"	225	(165)	390	(290)	540	(400)
7/8"	230	(170)	570	(420)	880	(650)
1"	345	(225)	850	(630)	1320	(920)

Metric Torque Specifications

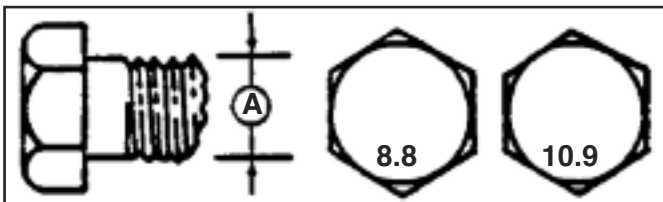

Bolt Diameter "A"	Bolt Torque*			
	8.8		10.9	
	N.m (lb-ft)		N.m (lb-ft)	
M3	.5	(.4)	1.8	(1.3)
M4	3	(2.2)	4.5	(3.3)
M5	6	(4)	9	(7)
M6	10	(7)	15	(11)
M8	25	(18)	35	(26)
M10	50	(37)	70	(52)
M12	90	(66)	125	(92)
M14	140	(103)	200	(148)
M15	225	(166)	310	(228)
M20	435	(321)	610	(450)
M24	750	(553)	1050	(774)

* Torque value for bolts and capscrews are identified by their head markings.

Torque values indicated above are valid for non-greased or non oiled threads and heads unless otherwise specified. Do not grease or oil bolts or capscrews unless otherwise specified in this manual. When using locking elements, increase torque values by 5%.

HYDRAULIC FITTING TORQUE

Tighten Flare Tube Fittings*

1. Check flare and flare seat for defects that might cause leakage.
2. Align tube with fitting before tightening.
3. Lubricate connection and hand tighten swivel nut.
4. To prevent twisting the tube(s), use two wrenches. Place one wrench on the connector body and with the second tighten the swivel nut to the torque shown.

Tube Size OD	Nut size Across Flats	Torque Value*	Recommended Turns to Tighten (After finger Tightening)	
			Flats	Turns
in.	in.	N.m (lb-ft)		
3/16	7/16	8 (6)	1	1/6
1/4	9/16	12 (9)	1	1/6
5/16	5/8	16 (12)	1	1/6
3/8	11/16	24 (18)	1	1/6
1/2	7/8	46 (34)	1	1/6
5/8	1	62 (46)	1	1/6
3/4	1 1/4	102 (75)	3/4	1/8
7/8	1 3/8	122 (90)	3/4	1/8

* The torque values shown are based on lubricated connections as in reassembly.

Hydraulic Hose

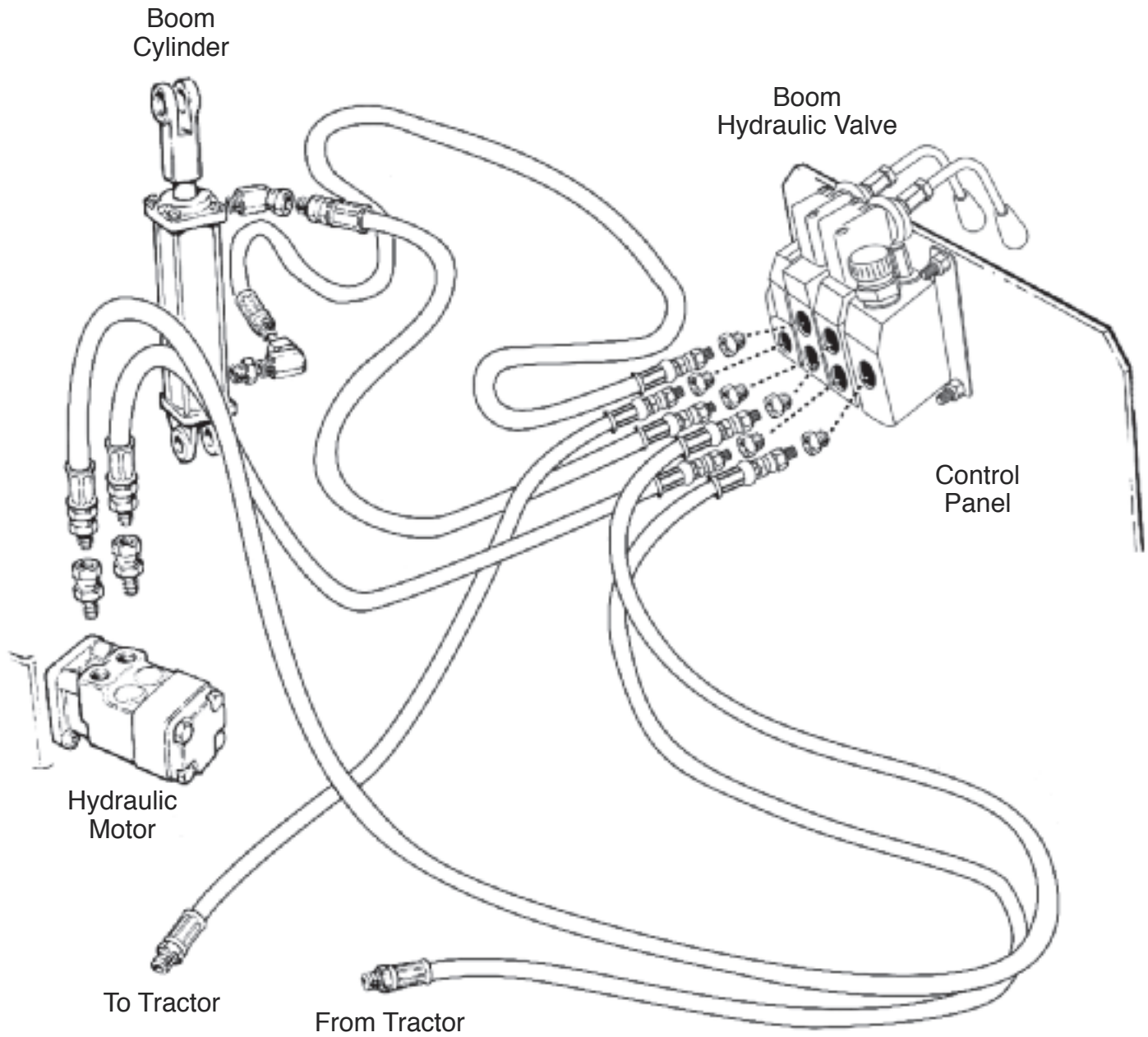

Hydraulic Hose

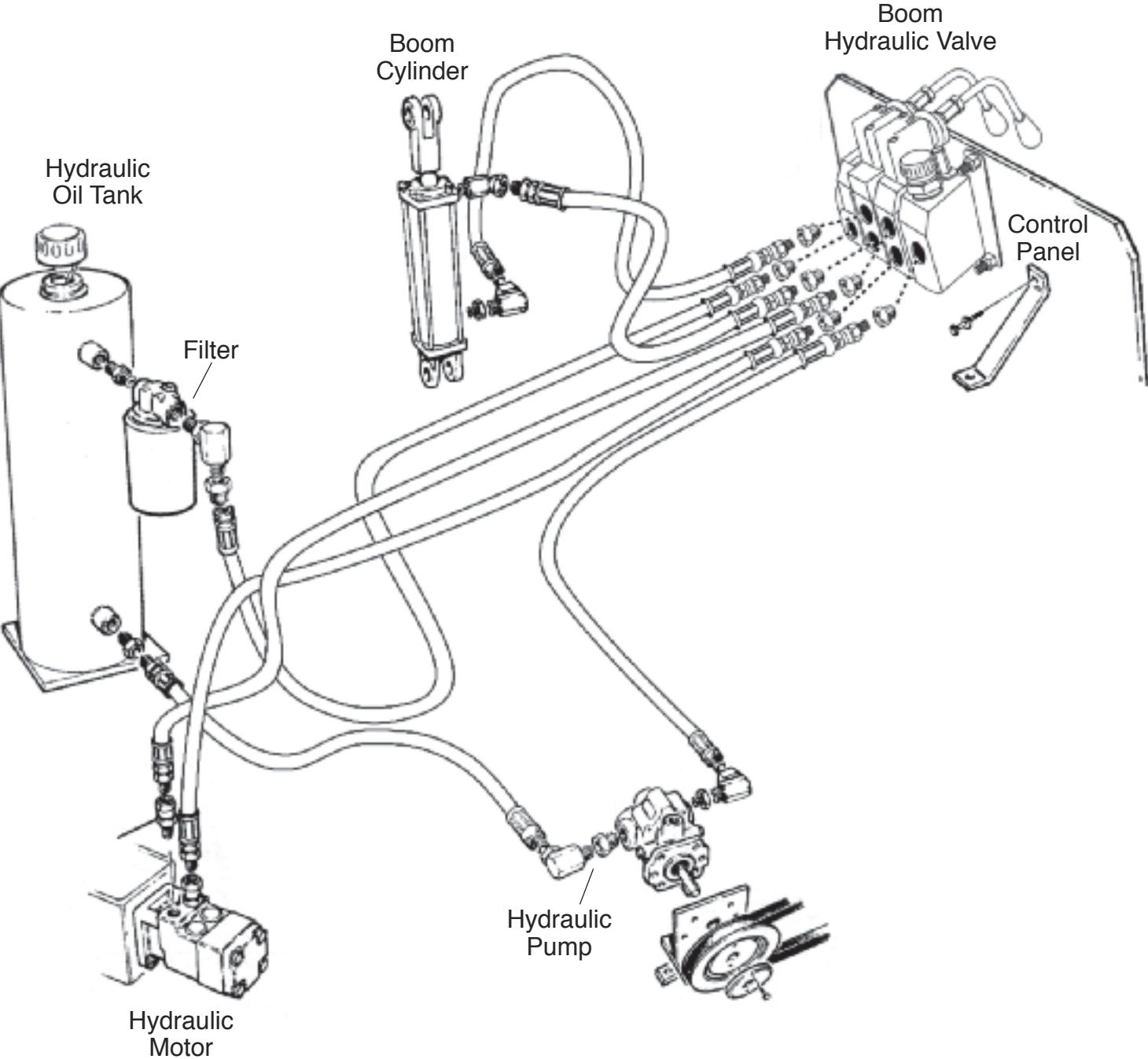

Troubleshooting

Troubleshooting

The heart and lungs of the Conveyair Grain Vac are the airlock and the blower (air pump). Both components must be operating at their recommended speed to obtain maximum efficiency from the machine.

The blower is driven by a belt and pulley system from the PTO on a tractor. The airlock is driven by a hydraulic motor powered by the hydraulic system on the tractor or by a self contained hydraulic system.

If you encounter a problem that is difficult to solve, even after having read through this troubleshooting section, please call your local dealer or the factory. **Before you call, please have this Operators Manual and the serial numbers from your Grain Vac ready.**

In North America call
(204) 822-4467

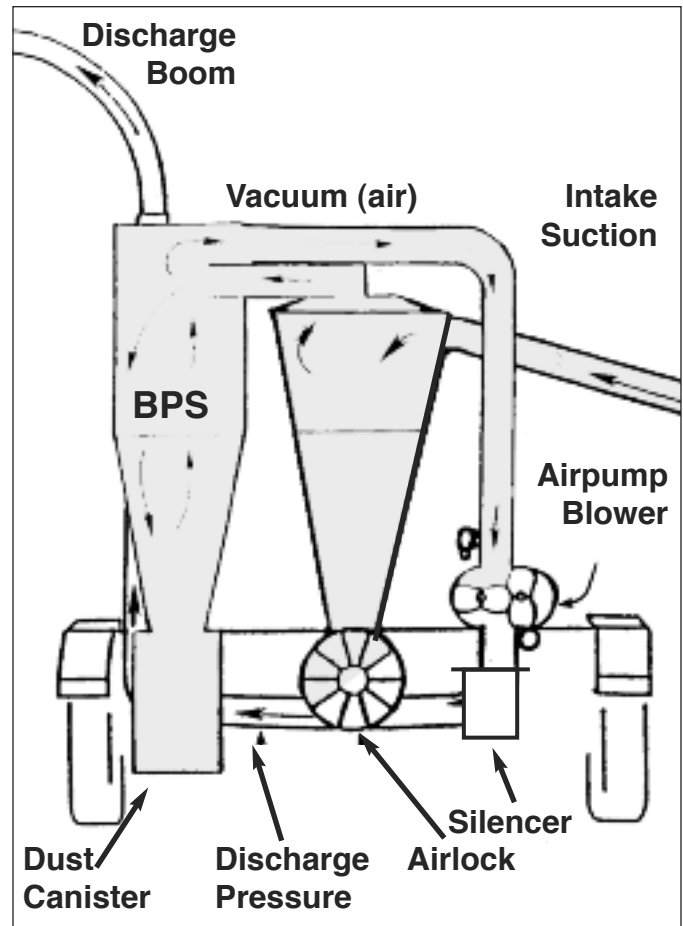

PROBLEM	CAUSE	SOLUTION
Low capacity	Tractor PTO runs slow.	Speed up tractor PTO to rated RPM for the model.
	540 Instead of 1000 RPM.	Change tractor or PTO speed shaft.
	Belts are slipping.	Tighten belts.
	Airlock runs too fast.	Slow down airlock speed until grain builds up to the level of inspection door.
	Improper air intake.	Adjust air intake.
	Improper use of nozzle.	Use full bin nozzle for larger piles and full bins. Use cleanup nozzle with flair for cleanup only. Do not submerge airslide in grain.
	Air leaks - Intake.	Check for worn coupler levers or missing coupler gaskets.
	Air leaks - Machine.	Check BPS, receiver section, and airlock gaskets.
		Check pressure and vacuum relief valve.
		Check clamps on airline between receiver tank and BPS and between BPS and blower.

Troubleshooting

PROBLEM	CAUSE	SOLUTION
Low capacity.	Improper piping.	Keep suction lines as short as possible. Minimize bends. Use straight length of pipe wherever possible. Use the poly hose for clean up only!
	Airlock tip clearance high.	Adjust airlock tips. (See PAGE 24)
	Airlock end plate clearance.	If rotor to end plate clearance is more than 0.015” consult the dealer or factory.
Excessive grain damage.	Too much air intake.	Adjust air intake nozzle.
	PTO running too fast.	Throttle down tractor.
	Damaged tubing or flexline.	Repair or replace.
	Insufficient grain supply.	Reposition nozzle.
Pulsation	Insufficient air at intake.	Open slide until grain flow becomes even.
	Airlock turning too fast.	Adjust airlock speed until grain is at level of the inspection door.
	Improper piping.	Replace steel flex or poly hose with rigid tubing wherever possible.
	Suction line too small.	Use proper line size.
	PTO running too slow .	Increase PTO RPM.
	Belts are slipping.	Tighten belts.
	Excessive airlock tip clearance.	Adjust airlock tips.
	Airlock turning too slow.	Adjust airlock speed until grain is at the proper level on the inspection door.
	Obstruction in suction.	Shut down machine and clear line obstruction.
BPS plugs	Airlock turning too slowly.	Increase airlock speed until grain is at the proper level on the inspection window.
	Airlock turning too fast.	Decrease airlock speed until the grain is at the proper level on the inspection door.
	Airlock not turning.	Check for proper hydraulic hook-up. Check for and remove obstruction airlock.

Troubleshooting

PROBLEM	CAUSE	SOLUTION
Airlock not turning at all.	Flow control valve wrong.	Reset flow control.
	Tractor hydraulic not properly engaged.	Reset tractor hydraulics.
	Obstruction in airlock.	Shift tractor hydraulic lever from FORWARD to REVERSE and back TO FORWARD. Repeat if obstruction does not clear up. If obstruction does not clear up, shut off tractor and grain vac, open inspection door and remove cause of obstruction.
Hydraulic oil heating up excessively.	Faulty tractor hydraulics.	Use different tractor.
	Low oil level.	Add oil.
Excessive wear on air lines.	Improper piping.	Minimize bends.
	Too much air flow.	Adjust airslides and airlock speed.
	Insufficient grain supply.	Reposition intake nozzle. Open grain supply doors.
	Excessive PTO speed.	Operate at proper recommended PTO speed.

Storage

Prior to storage we recommend that you thoroughly inspect your Conveyair.

1. Replace any worn or damaged components.
2. Wash and clean the machine. **After cleaning, run machine at low idle for 2 -3 minutes to dry the internal components.**



3. While machine is running at an idle, open the cleaning port and inject a cleaning agent such as WD40 for 45 - 60 seconds. This will coat the inside of the air pump to help prevent rusting.

4. Lubricate all grease points. Make sure all grease cavities have been filled with grease to remove any water residue.



5. Retract and stow all components and accessories and install cover over the boom pivot. (Keeps out dirt and small animals).

6. Inspect all hydraulic hoses, couplers, fittings and lines. Tighten any loose fittings. Replace any hose that is badly cut, nicked, abraded or is separating from the fitting.

7. Inspect, clean or empty the BPS.

8. Check the fluid level in the air pump oil reservoirs. Add oil as required.

9. Touch up all paint nicks and scratches to help prevent rusting.

10. For storage, select an area which is dry and level. Make sure unit is firmly blocked and will not tip or sink into a soft area. Place a plank under jack for added support.

ASSEMBLY	PARTS PAGE NO.
FRAME & WHEEL ASSEMBLY	37
RECEIVER TANK & DUST COLLECTOR	38
AIRLOCK & BLOWER ASSEMBLIES	39
BOOM & CYCLONE	40
BELT DRIVE	41
CLEAN UP & BIN NOZZLES	42
STEEL FLEX HOSE & COUPLERS	43
CLEAN UP HOSE & COUPLERS	44
DRIVESHAFT	45
SELF-CONTAINED HYDRAULIC SYSTEM	46 & 47
STANDARD CONTAINED HYDRAULIC SYSTEM	48 & 49

When ordering parts specify: model, size, serial number and ordering number.

Repair List FRAME & WHEEL ASSEMBLY

Revised 0109

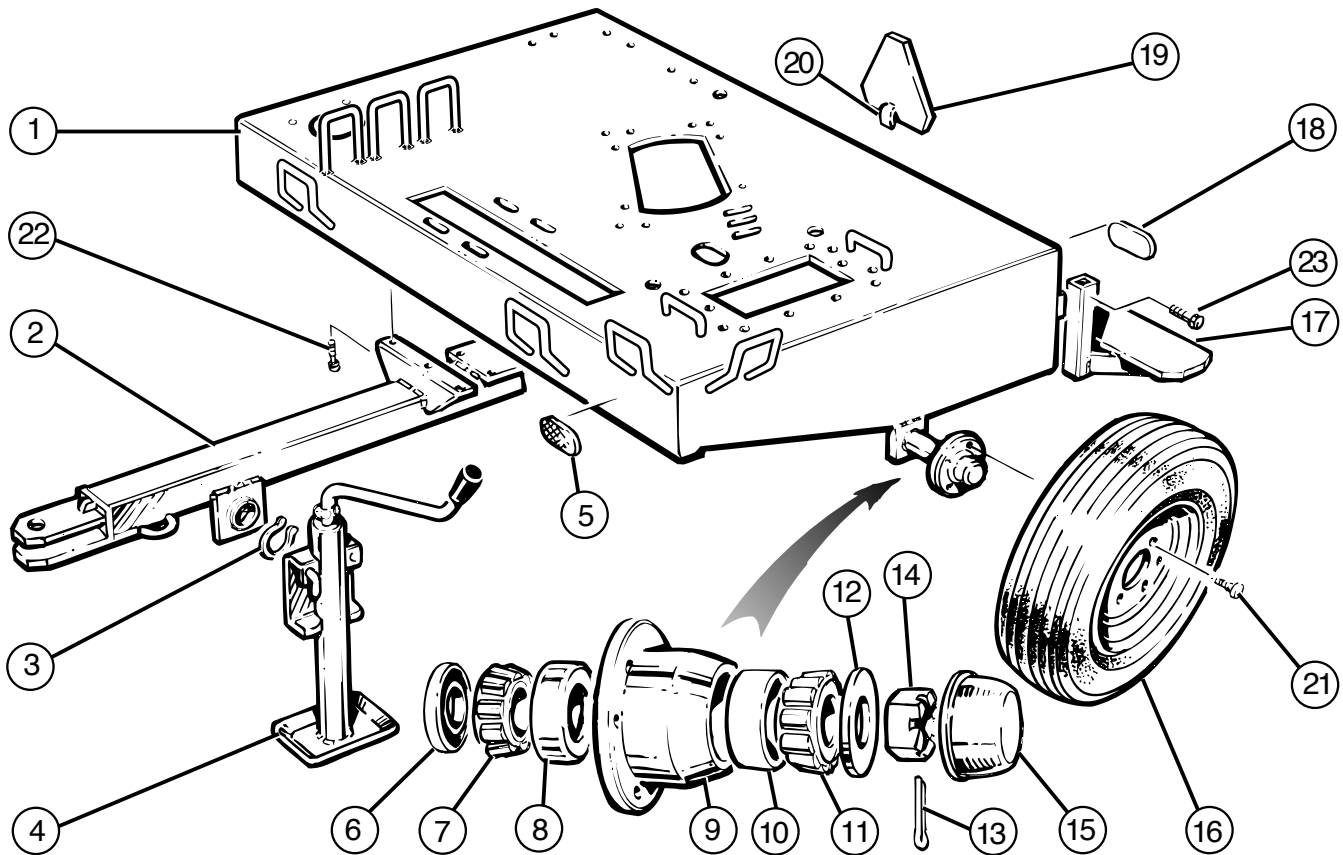

Item No.	Ordering No.	No. Req.d	Description
1	GV11600	1	Main frame
2	GV30500	1	Hitch assembly
3	GV30023	1	Snap ring
4	GV30001	1	Jack
5	GV60014	2	Amber reflector
6	GV20024	2	Wheel seal
7	GV20025	2	Bearing cone inner
8	GV20026	2	Bearing cup inner
9	GV30026	2	Wheel hub
10	GV20027	2	Bearing cone outer
11	GV20028	2	Bearing cup outer
12	GV56046	2	Flat washer 3/4"
13	GV60012	2	Cotter key
14	GV30027	2	Castle nut
15	GV30029	2	Dust cap
16	GV30512	2	Tire/rim assembly, ST205 x 15
17	GV11620	1	Boom support
18	GV60015	2	Red reflector
19	GV68503	1	Slow Moving Vehicle sign
20	GV11529	1	Slow Moving Vehicle spade 112409
21	GV30028	10	Wheel bolt
22	-	7	3/8" x 1 1/4" Gap screw, flat washer & lock nut
23	-	6	1/2" x 3" Gap screw, flat washer & lock nut

When ordering parts specify: model, size, serial number and ordering number

Receiver Tank & Dust Collector

REPAIR PARTS LIST

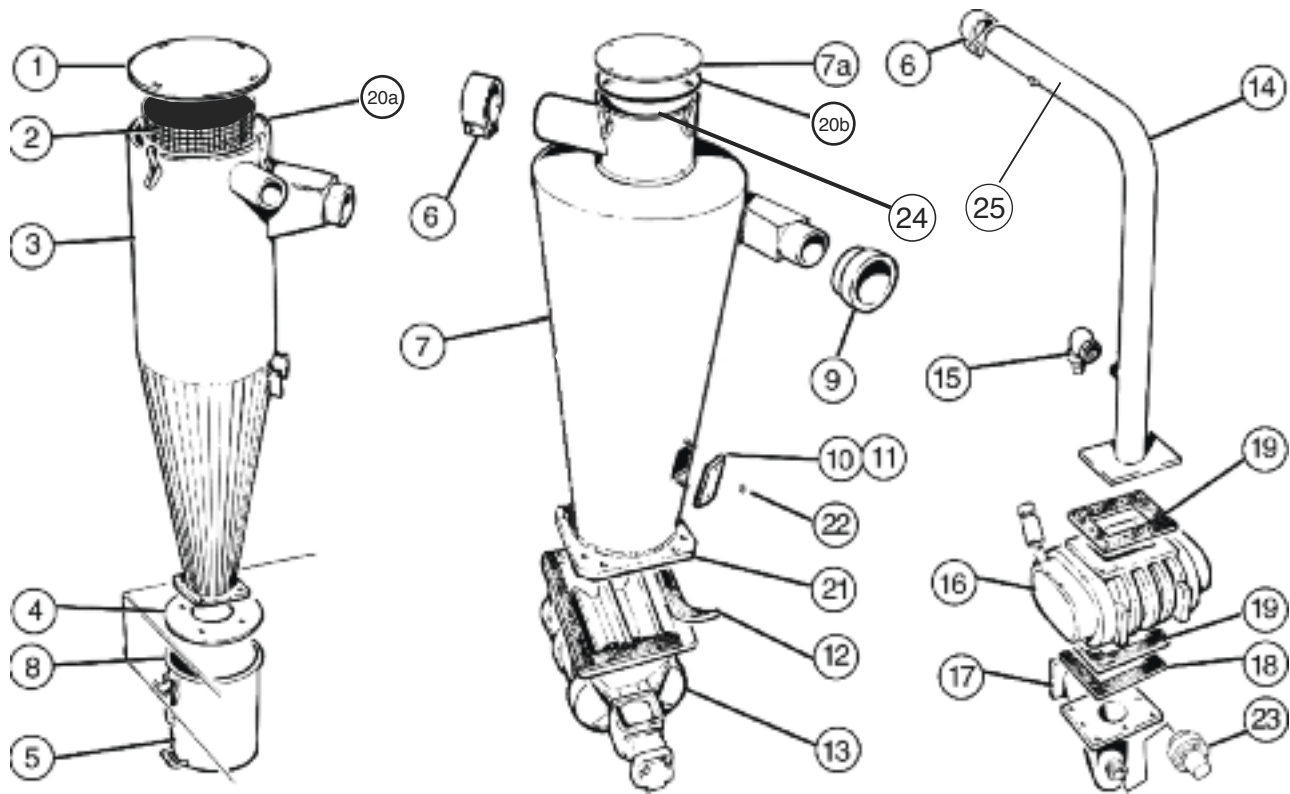

Item No	Ordering No. Model 6640	No. Req'd	Description
1	GV19504	1	Dust cyclone top plate
2	GV19514	1	Screen, Blower protection system
3	GV19500	1	Dust cyclone
4	GV15525	1	Ring, pail seal
5	GV19512	1	Dust cyclone pail
6	GV26011	2	5" Seal clamp
7	GV15640	1	Top Loading Receiver tank without coupler
7a	GV15632	1	Receiver tank top plate
8	GV64510	1	Pail gasket, 825 - 045 - 44 inches
9	GV26052	1	Female coupler
10	GV64001	1	Foam gasket - 1/4 in x 1 in x 28 inches
11	GV15520	1	Window receiver
12	GV64504	1	Foam gasket - 70 inches
13	GV10627	1	Airlock - see page 39
14	GV45505	1	Airline blower inlet
15	GV26119	1	Vacuum relief valve
16	GV14400	1	Blower complete with Oil filter - see page 39
17	GV45630	1	2 Piece airline blower output - see page 39
18	GV64030	1	Gasket Blower, 5.3 1/8
19	GV64501	2	Blower Gasket, 1/16 rubber
20a	GV64500	-	Rubber channel, 1/4 x 3/8 - 58"
20b	GV64500	-	Rubber channel, 1/4 x 3/8 - 38"
21	GV64503	-	Foam gasket, 60 inches
22	-	2	1/4" Flat washer & lock nut
23	GV26013	1	Pressure Relief Valve
24	GV15651	1	Screen Main Receiver Tank (anti-plug)
24	GV15653	1	Screen handle, factory installed

**REPAIR
PARTS LIST**

Airlock & Blower Assemblies

Revised 0109

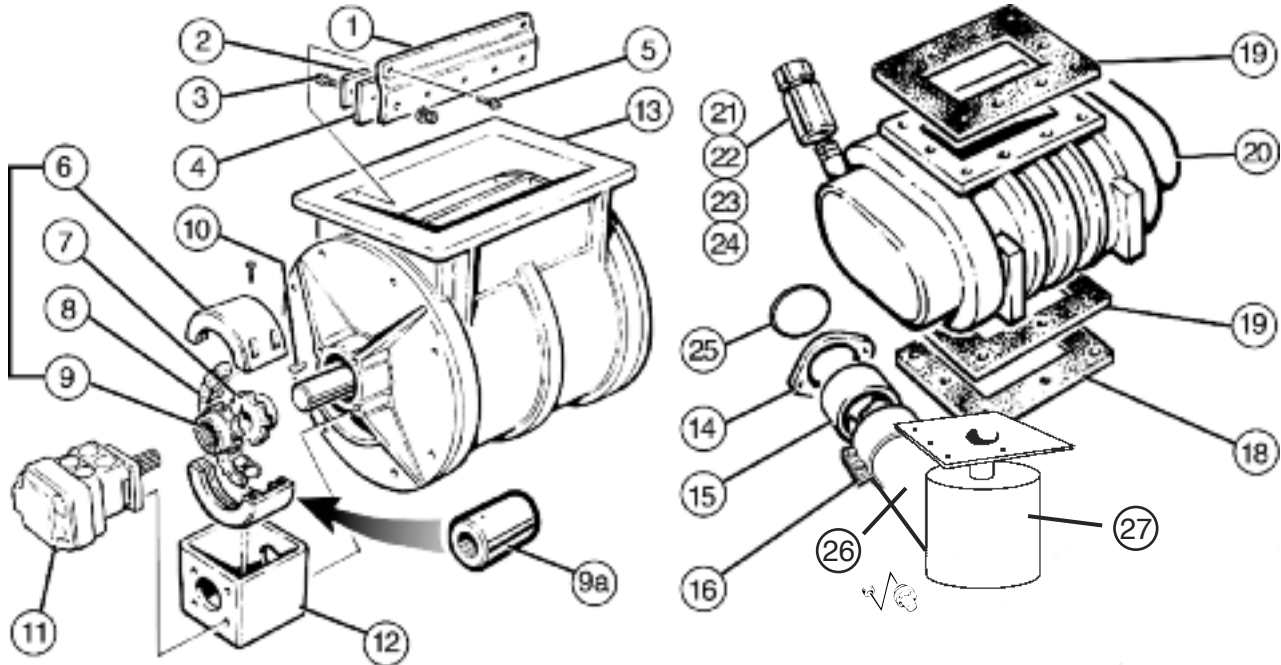

Item No.	Ordering No.	No. Req'd	Description
0	GV10627	1	Airlock assembly, complete with motor
1	GV10630	1	Wiper
2	GV10631	1	Retainer Wiper
3	-	3	Bolt, 1/4" x 1 1/2" complete with flat/L washer and nut
4	GV10632	1	Flex tip wiper
5	-	2	Bolt, 1/4" x 1 1/2" complete with flat/L washer and nut
6	GV20011	1	Chain coupler cover (to mid 1997)
7	GV20007	1	Chain coupler sprocket (to mid 1997)
8	GV20010	1	Chain - chain coupler (to mid 1997)
9	GV10021	1	Chain coupler sprocket - splined (to mid 1997)
9A	GV10513	1	Coupler weldment (mid 1997 models and up)
10	GV20006	1	Woodruff key
11	GV22228	1	Hydraulic motor - White
12	GV10017	1	Bracket for mounting airlock motor
13	GV10637	1	Airlock, less motor
00	GV14400	1	Blower complete with breather vents
14	GV45603	1	Flange airlock inlet
15	GV26044	1	reducer 6" to 5"
17	GV26011	1	Seal clamp. 5"
18	GV64030	1	Gasket, 5" x 3 1/8"
19	GV64501	2	Gasket, 1/16" rubber
20	GV14400	1	Blower less breathers
21	GV22136	2	Galvanized steel nipple, 3/4" x 2 1/2"
22	GV22044	2	Galvanized coupler nipple, 3/4"
23	GV22149	2	Galvanized hexagon bushing, 3/4" x 2 1/2"
24	GV14431	2	Breather vent
25	GV20015	1	O Ring
26	GV26013	1	Pressure relief valve
27	GV45650	1	Silencer

When ordering parts specify: model, size, serial number and ordering number

REPAIR PARTS LIST

BOOM & CYCLONE

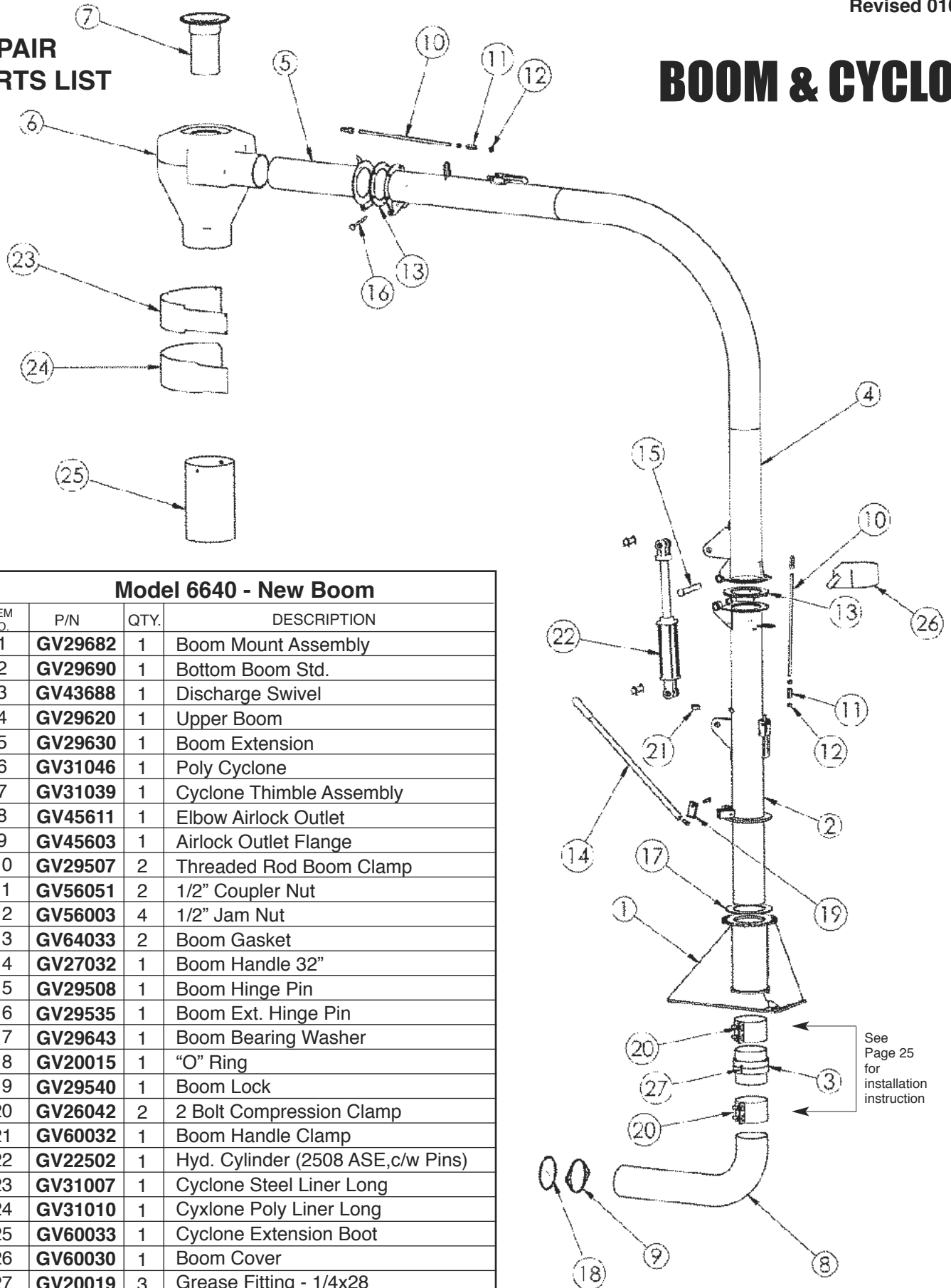

Model 6640 - New Boom

ITEM NO.	P/N	QTY.	DESCRIPTION
1	GV29682	1	Boom Mount Assembly
2	GV29690	1	Bottom Boom Std.
3	GV43688	1	Discharge Swivel
4	GV29620	1	Upper Boom
5	GV29630	1	Boom Extension
6	GV31046	1	Poly Cyclone
7	GV31039	1	Cyclone Thimble Assembly
8	GV45611	1	Elbow Airlock Outlet
9	GV45603	1	Airlock Outlet Flange
10	GV29507	2	Threaded Rod Boom Clamp
11	GV56051	2	1/2" Coupler Nut
12	GV56003	4	1/2" Jam Nut
13	GV64033	2	Boom Gasket
14	GV27032	1	Boom Handle 32"
15	GV29508	1	Boom Hinge Pin
16	GV29535	1	Boom Ext. Hinge Pin
17	GV29643	1	Boom Bearing Washer
18	GV20015	1	"O" Ring
19	GV29540	1	Boom Lock
20	GV26042	2	2 Bolt Compression Clamp
21	GV60032	1	Boom Handle Clamp
22	GV22502	1	Hyd. Cylinder (2508 ASE,c/w Pins)
23	GV31007	1	Cyclone Steel Liner Long
24	GV31010	1	Cyclone Poly Liner Long
25	GV60033	1	Cyclone Extension Boot
26	GV60030	1	Boom Cover
27	GV20019	3	Grease Fitting - 1/4x28

When ordering parts specify: model, size, serial number and ordering number

REPAIR PARTS LIST

Belt Drive

Revised 0109

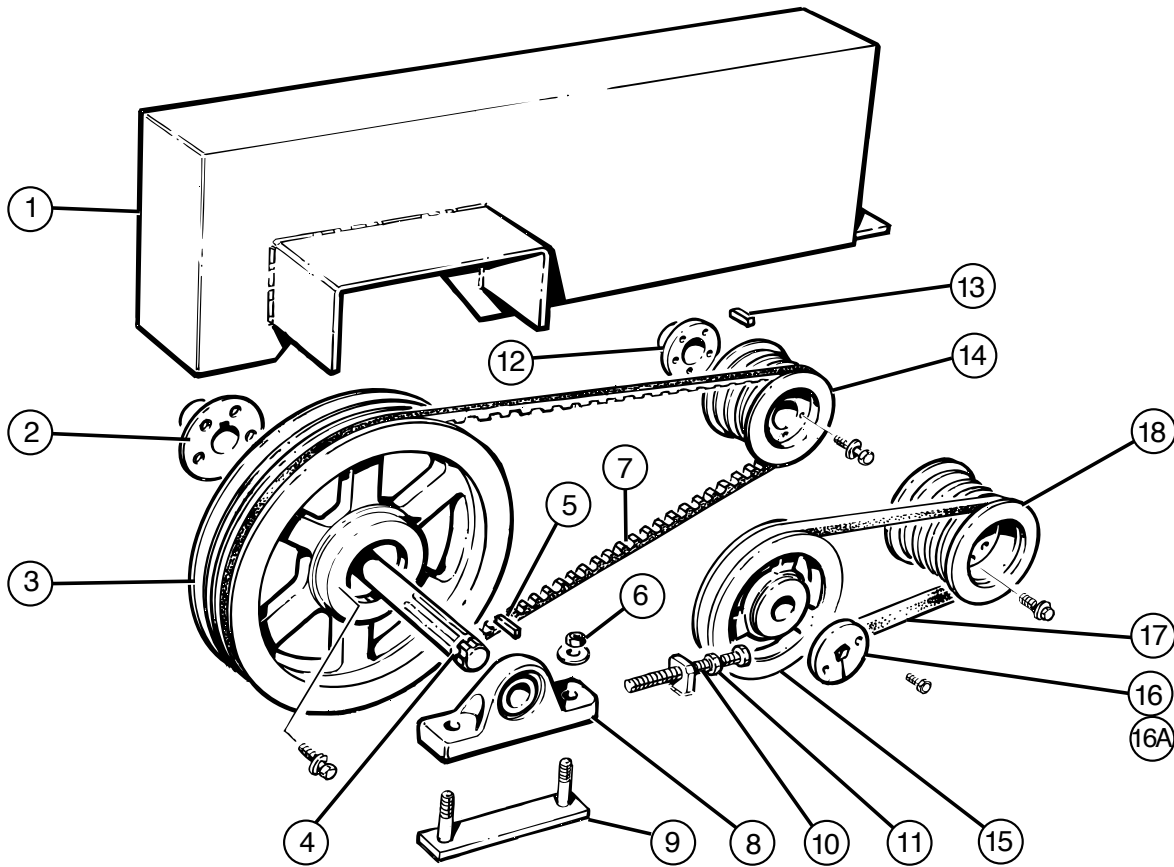

Item No.	Ordering No. Model 6640	No Req'd	Description
1	GV11520	1	Belt Cover
2	GV18504	1	Bushing, 1 3/8 complete with bolts
3	GV18050	1	Sheave
4	GV18502	1	Spline shaft, 1 3/8, 6 spline
5	GV20502	1	Key, 5/16 x 2
6	-	2	Flat washer and nylon nut, 1/2 inch
7	GV18505	5	V-Belt
8	GV20501	2	Pillow block bearing, 1 3/8
9	GV11503	2	Bolt weldment - bearing
10	GV56026	2	Tap bolt, 1/2 x 3 3/4
11	GV56003	2	Jam Nut, 1/2"
12	GV18010	1	Bushing, 1 7/16 complete with bolts
13	GV20018	1	Key, 3/8 x 2
14	GV18052	1	Sheave
SELF CONTAINED HYDRAULICS - OPTIONAL			
15	GV18510	1	Sheave, 6.4 QT
16	GV18511	1	Bushing, 9/16 QT complete with bolts
16a	GV18515	1	Bushing, 5/8 QT complete with bolts Serial 2659 & up (Key 3/16"x3/4" long)
17	GV18513	1	Belt, B38
18	GV18512	1	Sheave 5V, 5.2, replaces 18052

When ordering parts specify: model, size, serial number and ordering number

Cleanup & Full Bin Nozzles

REPAIR PARTS LIST

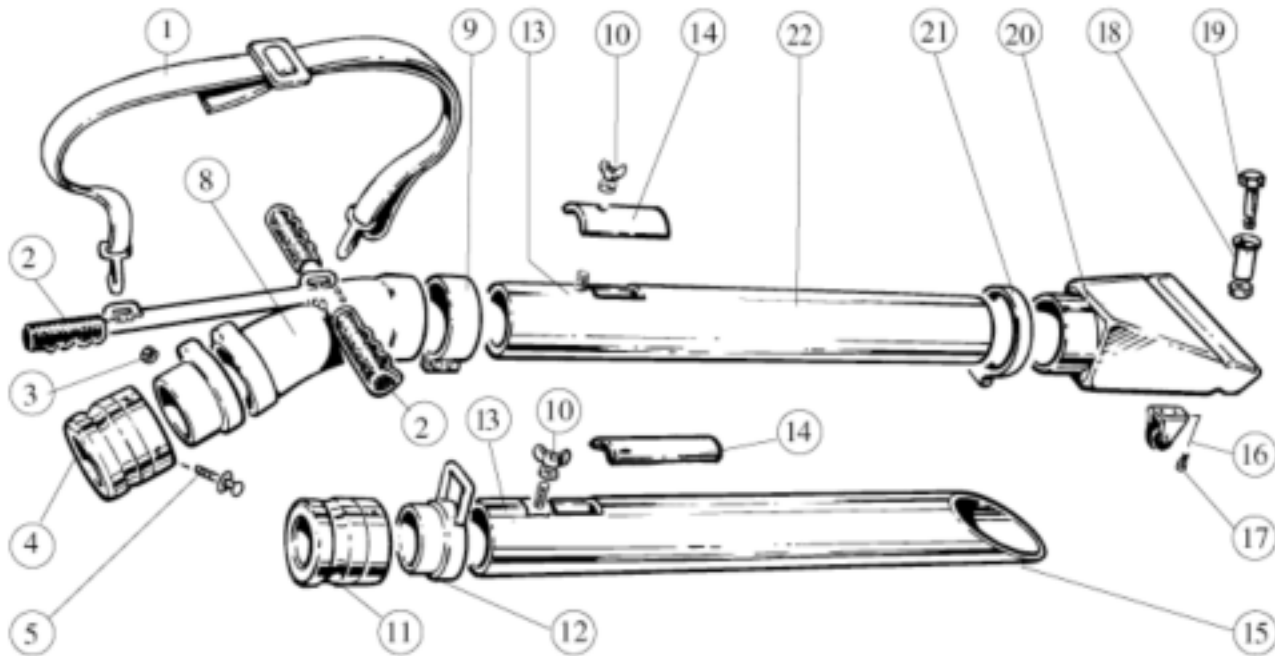

Item No.	Ordering No.	No Req'd	Description
0	GV43030	1	Cleanup assembly complete
1	GV60021	1	Shoulder strap
2	GV60008	1	Handle grip
3	-	2	Nylon nut 3/8"
4	GV26006	1	Male coupler
5	-	4	Carriage bolt, 1/4" x 3/4" complete with flat washer
8	GV43525	1	Rotary elbow weldment
9	GV26011	1	Seal clamp
10	-	2	Wing nut and flat washer, 3/8"
13	GV43004	2	Bottom slide assembly
14	GV43003	2	Top slide
16	GV60009	2	Rigid Caster
17	-	1	Carriage bolt, 1/4" x 3/4". complete with washer and nut
18	GV43060	1	Spacer pipe intake flare
19	-	1	Machine bolt, 1/4" x 3", flat lock washer and nut
20	GV43129	1	Bored intake flare
21	GV26063	1	Quick release T-bolt clamp
22	GV43031	1	Aluminum tube
00	GV43082	1	Intake Flare assembly, 16 to 20 (T-bolt clamp not included)
000	GV43610	1	Full bin nozzle assembly
10	-	2	Wing nut and flat washer, 3/8"
11	GV26051	11	Male coupler
12	GV43608	1	Handle
13	GV43004	2	Bottom slide assembly
14	GV43003	2	Top slide
15	GV43609	1	Tube

When ordering parts specify: model, size, serial number and ordering number

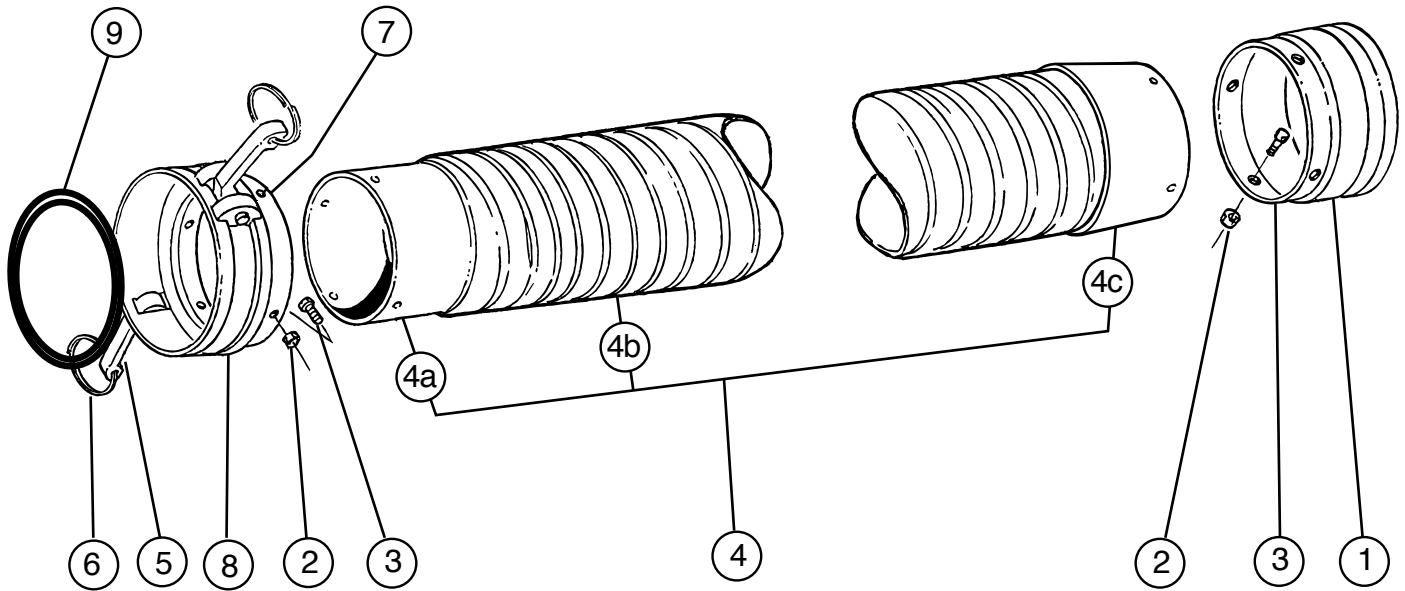

Item No.	Ordering No.	No. Req'd	Description
0	GV43047	1	Steel Flex Hose Assembly - includes 1-9
1	GV26051	1	Male Coupler
2	GV56030	8	Lock Nut, 1/4" NC x 3/4"
3	GV56027	8	Carriage Bolt, 1/4" NC x 3/4"
4	GV43048	1	Steel Flex Hose, 10 ft.
4a	GV43050	1	Tubing
4b	GV26073	1	Steel Flex Poly Lock, 10 ft.
4c	GV26047	1	Hose End Reducer
5	GV26086	2	Cam Lever
6	GV26085	2	Finger Ring
7	GV26082	2	Cam Lever Pin
8	GV26052	1	Fem Coupler Assembly - includes 5-7
9	GV64029	1	Coupler Gasket

When ordering parts specify: model, size, serial number and ordering number

**REPAIR
PARTS LIST**

Cleanup Hose & Couplers

Revised 0109

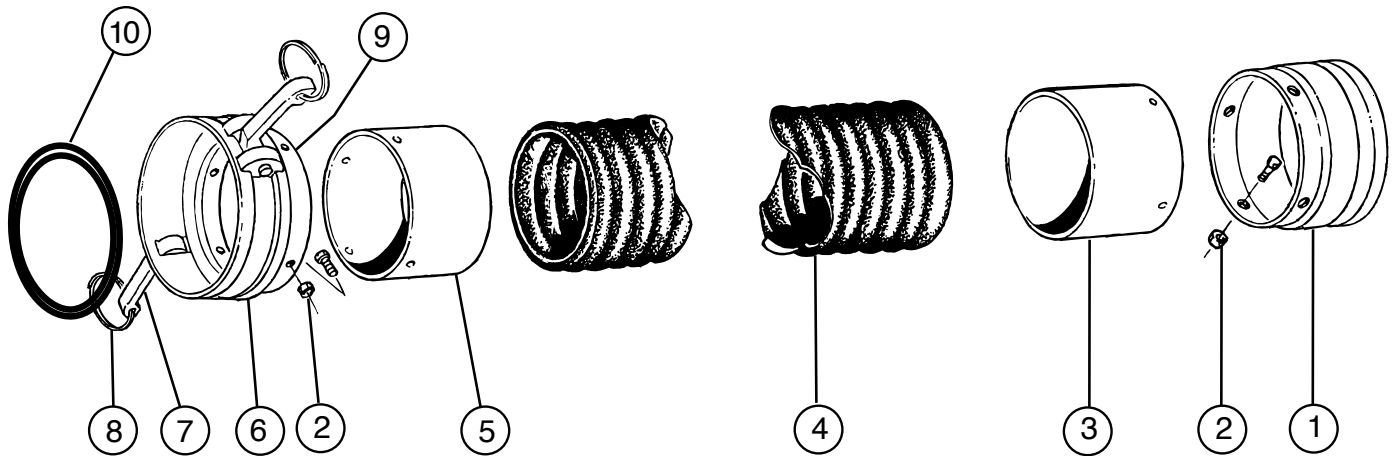

Item No.	Ordering No.	Description	Number Required
0	GV43034	Complete Hose Assembly - 4" x 14', 4" female x 5" male	1
1	GV26006	Male Coupler, 5"	1
2	GV56027	Carriage Bolt, 1/4" NC x 3/4", Lock Nut & Washer	8
3	GV26028	Reducer, 5" - 4"	1
4	GV26112	Poly Hose, 4" x 14'	14 feet
5	GV43035	Tube	1
6	GV26005	Female Coupler, 4" - includes 7 - 9	1
0	GV43056	Complete Hose Assembly - 5" x 14', 5" female x 6" male	1
1	GV26051	Male Coupler, 6"	1
2	GV56027	Carriage Bolt, 1/4" NC x 3/4", Lock Nut & Washer	8
3	GV26044	Reducer, 6" - 5"	1
4	GV26113	Poly Hose, 5" x 14'	14 feet
5	GV43029	Tube	1
6	GV26007	Female Coupler, 5" - includes 7 - 9	1
0	GV43019	Complete Hose Assembly - 6" x 14', 6" female x 6" male	1
1	GV26051	Male Coupler, 6"	1
2	GV56027	Carriage Bolt, 1/4" NC x 3/4", Lock Nut & Washer	8
4	GV26120	Poly Hose, 6" x 14'	14 feet
5	GV43050	Tube	2
6	GV26052	Female Coupler, 6" - includes 7 - 9	1
0	GV43079	Complete Hose Assembly - 5" x 14', 5" female x 5" male	1
1	GV26006	Male Coupler, 5"	1
2	GV56027	Carriage Bolt, 1/4" NC x 3/4", Lock Nut & Washer	8
4	GV26113	Poly Hose, 5" x 14'	14 feet
5	GV43029	Tube	2
6	GV26007	Female Coupler, 5" - includes 7 - 9	1
		Coupler parts	
7	GV26083	Cam Lever, for 4" & 5"	2
8	GV26085	Finger Ring	2
9	GV26081	Pin Cam Lever, for 4" & 5"	2
9	GV26082	Pin Cam Lever, for 6"	2
10	GV64027	Coupler Gasket, for 4"	2
10	GV64028	Coupler Gasket, for 5"	2
10	GV54029	Coupler Gasket, for 6"	2

When ordering parts specify: model, size, serial number and ordering number

REPAIR PARTS LIST

Driveshaft (LA MAGDALENA - 1000RPM)

Revised 0109

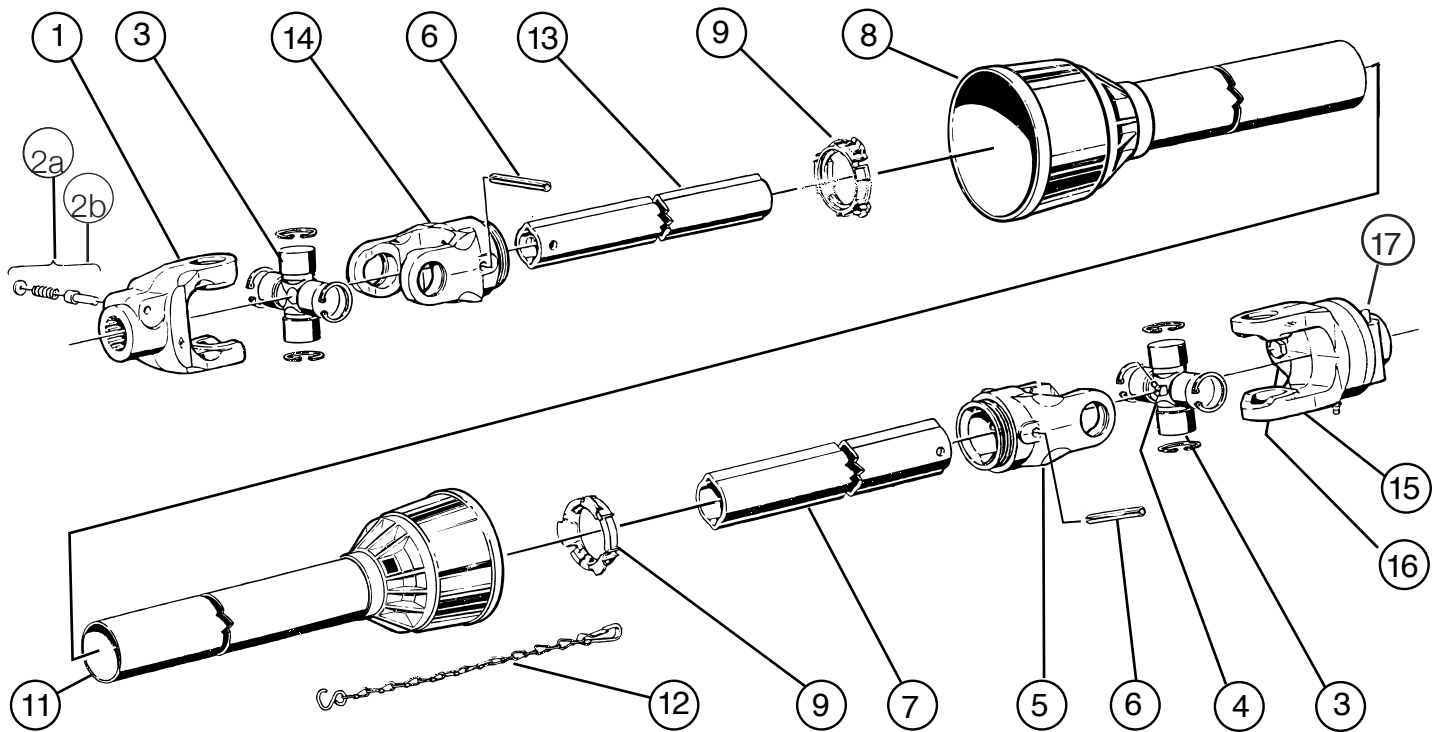

Item No.	Ordering No.	No. Req'd	Description
0	GV16102	1	Drive shaft complete for 5" and 6" units
1	GV16201	1	End yoke, 1 3/8" - 21 spline
2a.	GV16202	1	Pin Kit
2b.	GV16217	1	Pin Kit 2008 Model Vacs and later
3	GV16203	2	Cross and bearing kit
4	GV16110	2	Grease nipple
5	GV16204	1	Yoke, Inner profile
6	GV16112	2	Spring pin
7	GV16205	1	Inner profile
8	GV16208	1	Outer shield tube
9	GV16209	2	Shield bearing
10	GV16207	1	Shield Complete - Inner & Outer
11	GV16210	1	Inner shield tube
12	GV16211	1	Safety Chain
13	GV16212	1	Outer profile
14	GV16213	1	Yoke, outer profile
15	GV16214	1	Shear bolt clutch yoke
16	GV16206	1	Shear bolt, 10 mm x 65 mm, 8.8 DIN

When ordering parts specify: model, size, serial number and ordering number

Self Contained Hydraulic System

rev. 03/09

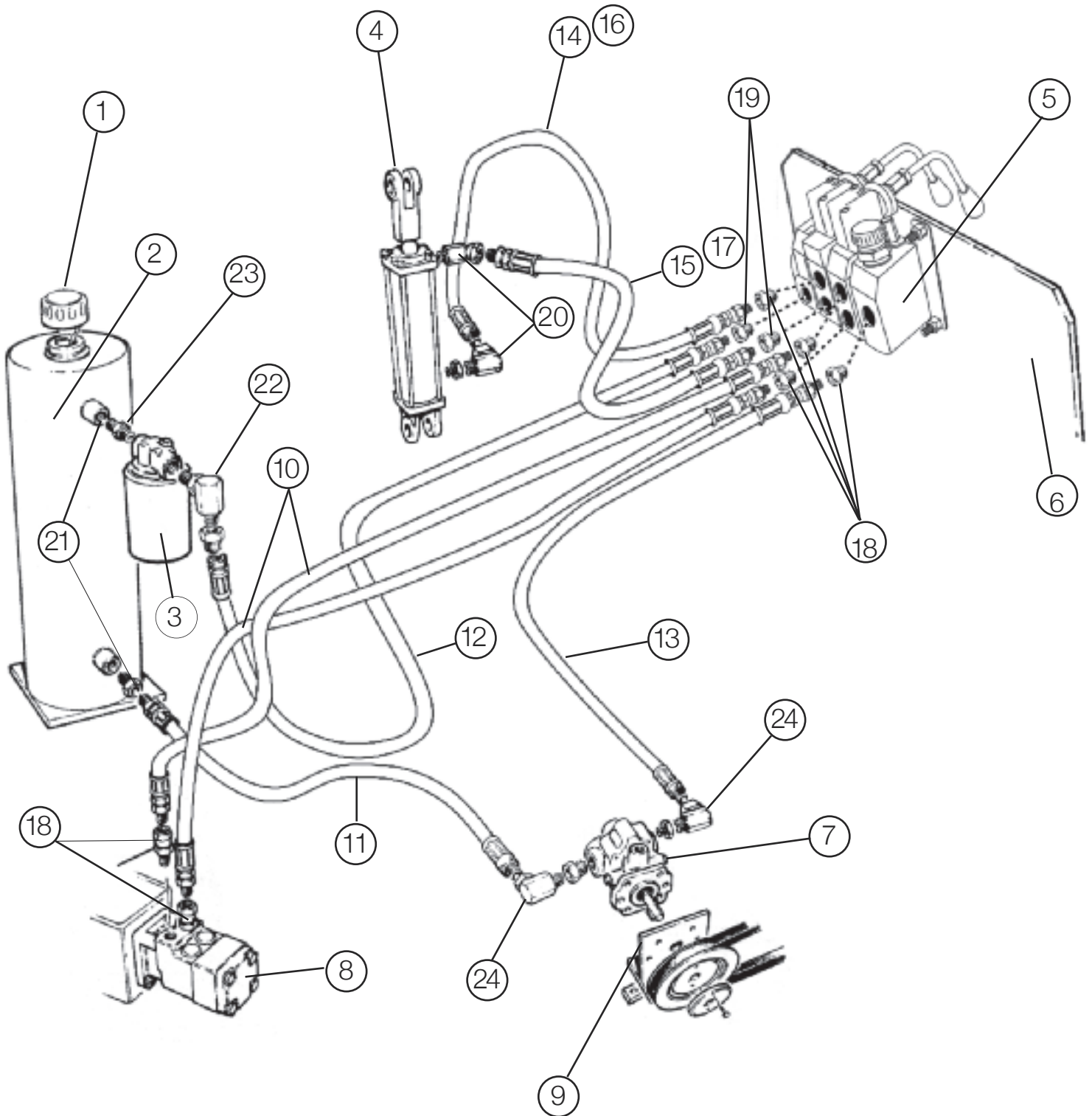

REPAIR PARTS LIST **Self Contained Hydraulic System**

Revised 03/09

Item No.	Ordering No	No. Required	Description
1	GV22066	1	Filter Breather
2	GV22550	1	Tank - for self-contained hydraulics
3	GV22068	1	Filter
4	GV22502	1	Hydraulic Cylinder
5	GV22700	1	Valve Bank
6	GV22510	1	Mount for Hydraulic Valve
7	GV22540	1	Hydraulic Pump
8	GV22228	1	Hydraulic Motor
9	GV22664	1	Mount for Hydraulic Pump
10	GV22702	1	Hose - Motor to Valve
11	GV22704	1	Hose - SCH Suction
12	GV22705	1	Hose - SCH Return
13	GV22706	1	Hose - SCH Pump to Valve
14	GV22707	1	Hose - Boom (138") (for Standard Boom)
15	GV22708	1	Hose - Boom (148") (for Standard Boom)
16	GV22709	1	Hose - Boom (154") (for High Reach Boom)
17	GV22710	1	Hose - Boom (164") (for High Reach Boom)
18	GV22714	6	Fitting 10MB-8MJ
19	GV22715	2	Fitting 10MB-6MJ
20	GV22716	2	Fitting 6MJ-6MP90
21	GV22718	2	Fitting 12MP-8MJ
22	GV22719	1	Fitting 8MB-8FJX
23	GV22720	1	Fitting 8MB-8FJX
24	GV22721	1	Fitting 12MB-8MJ90
25	GV22722	1	Fitting 10MB-8MJ90

When ordering parts specify: model, size, serial number and ordering number

Standard Hydraulic System

rev. 03/09

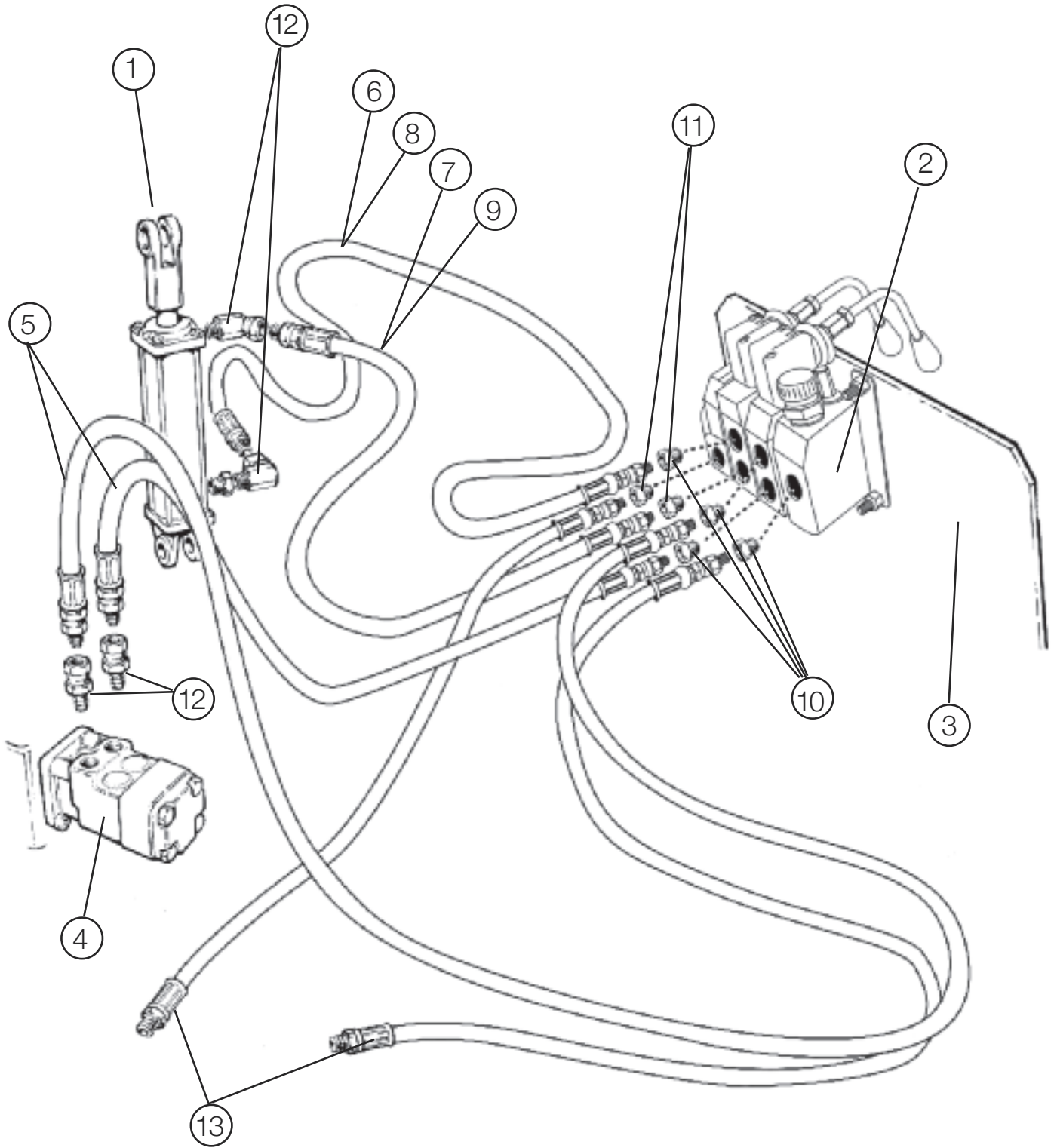

When ordering parts specify: model, size, serial number and ordering number

REPAIR **Standard Contained Hydraulic System** Revised 03/09

PARTS LIST

Item No.	Ordering No	No. Required	Description
1	GV22502	1	Hydraulic Cylinder
2	GV22700	1	Valve Bank
3	GV22510	1	Mount for Hydraulic Valve
4	GV22228	1	Hydraulic Motor
5	GV22702	1	Hose - Motor to Valve
6	GV22707	1	Hose - Boom (138") (for Standard Boom)
7	GV22708	1	Hose - Boom (148") (for Standard Boom)
8	GV22709	1	Hose - Boom (154") (for High Reach Boom)
9	GV22710	1	Hose - Boom (164") (for High Reach Boom)
10	GV22714	6	Fitting - 10MB-8MJ
11	GV22715	2	Fitting - 10MB-6MJ
12	GV22716	2	Fitting - 10MJ-6MP90
13	GV22703	2	Hose - Tractor (Inlet/Return)

When ordering parts specify: model, size, serial number and ordering number

Limited Warranty

Bühler Manufacturing Ltd. (hereafter referred to as "Bühler") products are warranted for a period of twenty-four (24) months from the date of delivery to the original purchaser, to be free from defects in material and workmanship when used under correct, normal agricultural use and proper applications.

Bühler's obligation under the warranty shall be limited to the repair or exchange (at Bühler's option) of any part which proves to be defective as provided.

The buyer shall be responsible for all expenses incurred as a result of repairs, labour, parts, transportation or any other work unless a Bühler dealer has authorized such expenses in advance. It is the responsibility of the dealer to get approval from Bühler before authorizing warranty work being done. Bühler reserves the right to either inspect the product at the buyer's location or have the defective part returned to the factory for inspection.

The above warranty does not extend to goods damaged or subject to accidents, abuse or misuse after shipment from Bühler's factory, nor to goods altered or repaired without authorization from Bühler.

Bühler makes no Express Warranty other than those which are specifically described. Any description of goods, including any reference to specifications in catalogues, circulaires, and other written material published, is for the sole purpose of identifying goods and shall conform to such descriptions. Any sample or model is for

illustration purposes only, and does not create an Express Warranty that the goods conform to the sample or model. The dealer is solely responsible for determining the suitability of goods sold.

BÜHLER MAKES NO WARRANTY OF MERCHANTABILITY OF FITNESS FOR A PARTICULAR PURPOSE.

This warranty is expressly in lieu of all other warranties expressed or implied. Bühler will in no event, be liable for any incidental or consequential damages, nor for any sum in excess of the price received for the goods for which liability is claimed.

Claims for warranty must be made on Bühler Warranty Claim Forms within 10 days of the failure occurrence. Warranty Authorization numbers are available from the factory and must be indicated on the Warranty Claim Form for all claims over a total dollar value of \$100.00.

The labour rate for warranty work where applicable will be credited at a rate determined by Bühler.

IMPORTANT: *Components or accessories, including blower, airlock, flex, hose and hose accessories that come in contact with material being moved, carry no warranty for wear. Warranty is void when unit is used for moving material other than cereal grains, grass seeds or pulse crops.*

Bühler Manufacturing

For more information please contact:

Bühler Manufacturing

301 Mountain Street S. • Morden, MB Canada R6M 1X7

Telephone : (204) 822-4467

Fax : (204) 822-6348

Web site : www.buhler.com

DIVISION LOCATIONS

Farm King Division
301 Mountain Street S.
Morden, MB R6M 1X7
Tel : (204) 822-4467
Fax : (204) 822-6348

Allied/Inland Division
1260 Clarence Avenue
Winnipeg, MB R3T 1T2
Tel : (204) 284-6100
Fax : (204) 477-2325

B.I.I. Division
1330 43 Street NW
 Fargo, ND 58102
Tel : (701) 282-7014
Fax : (701) 282-5865

U.S. WAREHOUSES

AR, West Memphis
(870) 732-3132

GA, Stone Mountain
(770) 908-9439

ID, Meridian
(208) 887-6006

IN, Clarksville
(812) 284-3376

KS, Wichita
(316) 265-9577

MN, Lakeville
(952) 469-5267

MT, Billings
(406) 248-7771

ND, Bismarck
(701) 223-1886

ND, Fargo
(701) 282-7003

NE, Blair
(402) 426-8211

OH, Youngstown
(330) 793-0862

OR, Beaverton
(503) 641-1865

SD, Huron
(605) 352-8516

TX, Houston
(713) 928-2632

UT, Salt Lake City
(801) 972-4321

WI, Portage
(608) 742-1370

CANADIAN WAREHOUSES

BC, Abbotsford
(604) 864-2665

AB, Edmonton
(780) 962-6991

SK, Regina
(306) 781-2300

ON, Woodstock
(519) 539-0435

QC, Dorion
(450) 455-4840

OFFSHORE WAREHOUSES

Burando Hill
Katanning
W. Australia
011-618-98-214422
Chihuahua, Mexico
011-52-158-90306

John Kerr Equipment Ltd.
Wilcoxholm Farm
Linlithgow, W. Lothian
Scotland
011-441-506-842280
Skovde, Sweden
011-46-500-452651
Naestved, Denmark
011-45-557-29511

bühler
Buhler Trading Inc.

301 Mountain Street S.
Morden, MB
Canada R6M 1X7
Tel.: (204) 822-4467
Fax: (204) 822-6348
www.buhler.com