

bühler

farm king



16" x 104' Backsaver Auger

Operator's and Parts Manual
FK370

2009

TABLE OF CONTENTS

DESCRIPTION	PAGE
WARRANTY	1
INTRODUCTION	2
SAFETY	3
Safety	3
General Safety	4
Start Up Safety	4
Operation Safety	5
Transport Safety	5
Service and Maintenance Safety	6
Storage Safety	7
Safety Signs	7
Safety Sign Installation	7
ASSEMBLY	10
Assembly Instructions	10
Light Kit Assembly Instructions	17
OPERATION	19
Operating Instructions	19
Theory of Operation	22
MAINTENANCE	23
Storage	24
Greasing Procedure	25
Bolt Torque	26

TABLE OF CONTENTS – con'td.

PARTS DRAWINGS	27
Tube Assembly Drawings.....	27
Tube Assembly Parts List.....	29
Lift Arm and Undercarriage Drawing	32
Lift Arm and Undercarriage Parts List.....	33
Intake System Assembly Drawings	35
Intake System Assembly Parts List	37
Hydraulics Drawing.....	40
Hydraulics Parts List.....	41
Light Kit Drawing	42
Light Kit Wiring Schematic & Parts List	43
Cylinder Drawing and Parts List	44
PTO Drawing & Parts List.....	45
Intake Auger Gearbox Drawing	46
Intake Auger Gearbox Parts List	47
Input Auger Gearbox Drawing	48
Input Auger Gearbox Parts List	49
1000 rpm Gearbox Drawing	50
1000 rpm Gearbox Parts List.....	51
Hydraulic Winch Drawing & Parts List	52
 SHIPPING KIT AND BUNDLE NUMBERS	 53

WARRANTY POLICY

Buhler Manufacturing products are warranted for a period of twelve (12) months (90 days for commercial application) from original date of purchase, by original purchaser, to be free from defects in material and workmanship under correct, normal agricultural use and proper applications.

Buhler Manufacturing's obligations under this warranty shall be limited to the repair or exchange, at Buhler Manufacturing's option, of any Buhler Manufacturing product or part which proves to be defective as provided. Buhler Manufacturing reserves the right to either inspect the product at the buyer's location or have it returned to the factory for inspection.

The above warranty does not extend to goods damaged or subject to accident, abuse or misuse after shipment from Buhler Manufacturing's factory, nor to goods altered or repaired by anyone other than an authorized Buhler Manufacturing representative.

Buhler Manufacturing makes no Express Warranties other than those, which are specifically described. Any description of goods, including any references and specifications in catalogues, circulars and other written material published, is for the sole purpose of identifying goods and shall conform to such descriptions. Any sample or model is for illustrative purposes only and does not create an Express Warranty that the goods conform to sample or model shown.

The purchaser is solely responsible for determining suitability of goods sold. This warranty is expressly in lieu of all other warranties expressed or implied. Buhler Manufacturing will in no event be liable for any incidental or consequential damages whatsoever. Nor for any sum in excess of the price received for the goods for which liability is claimed.

WARRANTY CLAIMS:

Warranty requests must be prepared on Buhler Manufacturing Warranty Claim Forms with all requested information properly completed. Warranty Claims must be submitted within a thirty (30) day period from date of failure repair.

WARRANTY LABOR:

Any labor subject to warranty **must** be authorized by Buhler Manufacturing. The labor rate for replacing defective parts, where applicable, will be credited at 100% of the dealer's posted shop rate. Defective parts will receive an extra 10% discount to assist with freight or other incidental costs.

GOVERNMENT LEGISLATION:

Warranty terms and conditions are subject to Provincial or State legislation.

IMPORTANT FACTS:

Buckets and Bucket Tines Carry No Warranty

Bent Spears Carry No Warranty

Snowblower Fan Shafts Carry No Warranty

Mower Blades Carry No Warranty

Portable Auger Parts Have Two (2) Year Warranty

Loader Parts Have Two (2) Year Warranty

IMPORTANT NOTE:

This warranty does not apply to rentals.

INTRODUCTION

Buhler Farm King gives you more choices to match your auger to your bins, power sources and operating convenience. The superior scissor lift system features two one way hydraulic cylinders with restrictor valves to control the rate of descent in the event of hydraulic hose failure. This feature is safer than conventional cable systems. Also, note the extra wide undercarriage and wheel tread providing better stability at greater heights, particularly in windy conditions. This unique mechanical linkage is designed to use less hydraulic pressure to lift the auger, even when fully loaded. The pivoting hopper Lift arm may be flipped over for left or right transport position. The hitch is adjustable for various tractor hitch lengths. The shut off valve is designed to keep your auger in the position you set it.

The cross auger and main auger are driven by two internal gearboxes, easily reached for service. Because of the large input and intake boxes, capacity is not restricted. A two wheel power mover allows you to move the hopper back and forth with finger tip control. Other advanced features include a light kit, heavy duty 1000 rpm gearbox and hydraulic winch.

Keep this manual handy for frequent reference. All new operators or owners must review the manual before using the equipment and at least annually thereafter. Contact your Buhler Dealer if you need assistance, information, or additional copies of the manual. Visit our website at www.buhler.com for a complete list of dealers in your area.

The directions left, right, front and rear, as mentioned throughout this manual, are as seen facing in the direction of travel of the implement.

SAFETY

Remember, YOU are the key to safety. Good safety practices not only protect you, but also the people around you. Make these practices a working part of your safety program. Be certain that everyone operating this equipment is familiar with the recommended operating and maintenance procedures and follows all the safety precautions. Most accidents can be prevented. Do not risk injury or death by ignoring good safety practices.

The alert symbol is used throughout this manual. It indicates attention is required and identifies hazards. Follow the recommended precautions.



the safety alert symbol means...

ATTENTION! BECOME ALERT! YOUR SAFETY IS INVOLVED!

CAUTION

The caution symbol indicates a potentially hazardous situation that, if not avoided, may result in minor or moderate injury. It may also be used to alert against unsafe practices.

WARNING

The Warning Symbol indicates a potentially hazardous situation that, if not avoided, could result in death or serious injury, and includes hazards that are exposed when guards are removed. It may also be used to alert against unsafe practices.

DANGER

The Danger Symbol indicates an imminently hazardous situation that, if not avoided will result in death or serious injury. This signal word is to be limited to the most extreme situations, typically for machine components that, for functional purposes, cannot be guarded.

GENERAL SAFETY INSTRUCTIONS

Have a first-aid kit available for use and know how to use it.

Have a fire extinguisher available, stored in a highly visible location, and know how to use it.

Wear appropriate protective gear. This list may include but is not limited to:

- Hard hat
- Protective shoes with slip resistant soles
- Protective glasses or goggles
- Heavy gloves
- Wet weather gear
- Hearing protection
- Respirator or filter mask

Read and understand the Operator's Manual and all safety signs before operating, servicing, adjusting, repairing, or unplugging the equipment.

Do not attempt any unauthorized modifications to your Buhler product as this could affect function or safety, and could affect the life of the equipment.

Inspect and clean the working area before operating.

Keep hands, feet, clothing, and hair away from moving parts.

Ensure bystanders are clear of the area before operating.

START UP SAFETY

Do not let inexperienced operators or children run this equipment.

Place all tractor and machine controls in neutral before starting.

Operate only with ROPS and seatbelt equipped tractors.

Do not operate inside a building unless there is adequate ventilation.

Ensure all shields are in place and in good condition before operating.

Stay clear of PTO shaft and machine when engaging PTO.

The auger must be on a level surface and wheels free to move when raising or lowering. Everyone should be kept clear during these operations.

OPERATION SAFETY

Do not permit riders.

Do not wear loose fitting clothing during operation.

Empty the auger before moving, to prevent upending.

The Backsaver Auger should be attached to the drawbar of the tractor at all times during operations.

Do not allow anyone other than the operator close to the auger when in operation.

Never stand under the auger while raising or lowering.

When filling tall bins, tanks, or granaries, it is advisable to anchor the auger to the bin or building to prevent it from being tipped over by the wind or a sudden movement.

Do not operate Intake Auger when it is folded in transport position.

Never raise the intake end of the auger above waist high, as the balance shifts forward, and the auger will tip over.

Stay away from overhead obstructions and power lines during operation and transporting. Electrocutation can occur without direct contact.

TRANSPORT SAFETY

Review Transport Safety instructions in tractor manual before moving.

Check with local authorities regarding transport on public roads. Obey all applicable laws and regulations.

Do not tow equipment that does not have brakes at speeds over 32 km/h (20 mph).

Do not tow equipment that does not have brakes that, when fully loaded, has a mass (weight) over 1.5 t (3300 lb) and more than 1.5 times the mass (weight) of the towing unit.

Make sure the SMV (Slow Moving Vehicle) emblem and all the lights and reflectors that are required by the local highway and transport authorities are in place, are clean, and can be seen clearly by all overtaking and oncoming traffic.

Never have the equipment in operation during transport.

Always transport the Backsaver Auger in the down position, carrying the weight of the auger on the undercarriage itself, and not the hydraulic cylinder.

TRANSPORT SAFETY – cont'd.

Take extreme caution in maneuvering on or around tight corners so as not to catch the end of the auger on trees, buildings, power lines, etc.

The equipment should never be towed without the safety chain securely attached to the auger and the towing vehicle.

When moving the auger on the road, always use a red flag, or if absolutely necessary to move at night, accessory lights for adequate warning to operators of other vehicles.

Always travel at a safe speed.

Inflate transport tires to recommended pressure.

SERVICE AND MAINTENANCE SAFETY

Stop engine, set brake, remove ignition key, and wait for all moving parts to stop before servicing, adjusting, repairing, or unplugging.

Support the equipment with blocks or safety stands before working beneath it.

Follow good shop practices including

- Keep service area clean and dry
- Be sure electrical outlets and tools are properly grounded
- Use adequate light for the job

Use only tools, jacks, and hoists of sufficient capacity for the job.

Replace and secure all shields removed during servicing before operating.

Use heavy leather gloves to handle sharp objects.

Check hydraulics regularly for leaks. Use cardboard to look for leaks, and use hand and eye protection.

Relieve pressure on hydraulic system before repairing or adjusting.

Failure to follow proper procedures when mounting a tire on a wheel or rim can produce an explosion, which may result in serious injury or death.

STORAGE SAFETY

Store the unit in an area away from human activity.

Do not permit children to play on or around the stored machine.

Support the frame on stands and blocks to provide a secure base.

When storing an auger, park it on level ground so that the bottom end will never be over its center of gravity.

Block the wheels of the auger so that the auger will not move and tear the jack from its mount.

SAFETY SIGNS

The following illustration shows the approximate location and detail of safety signs. Keep all safety signs clean and legible and replace any that are damaged or missing. When original parts are replaced, any safety signs affixed to those parts should be replaced as well. Replacement safety signs are available from your local dealer.

INSTALLATION

To install safety signs, ensure the installation area is clean and dry. Decide on the exact position before you remove the backing paper. Remove the smallest portion of the split backing paper and align over the specified area. Carefully press in place. Slowly peel back the remaining paper and smooth the remaining portion in place. Small air pockets can be pierced with a pin and smoothed out.

16" AUGER SAFETY SIGNS

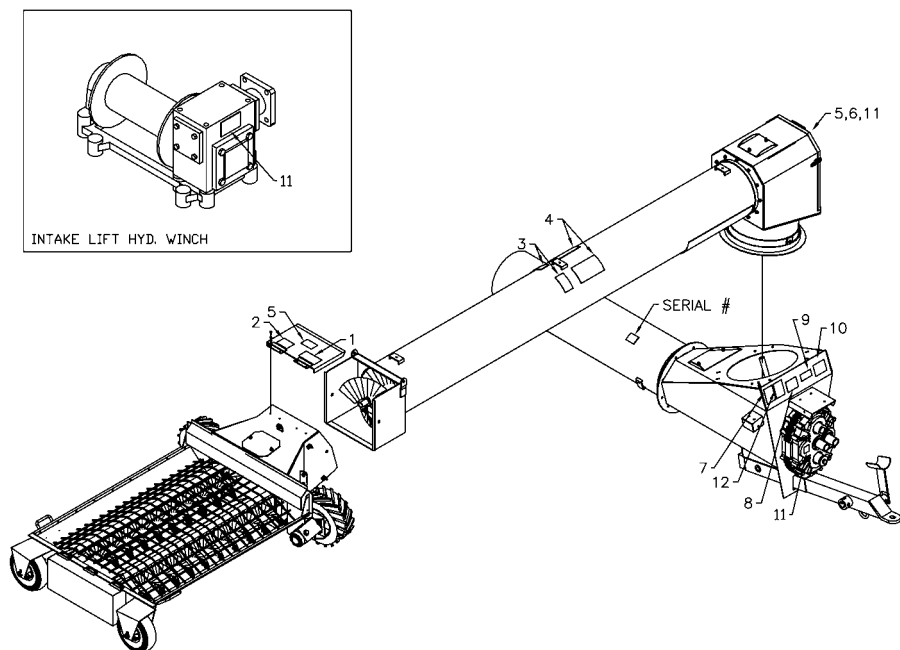

SAFETY SIGNS

Replace safety signs immediately should they become damaged, torn or illegible. Obtain replacements from your authorized dealer using the part numbers shown.



#1



#3

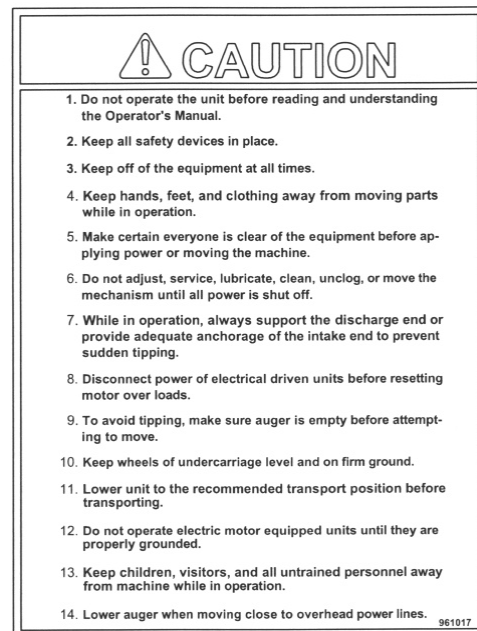

#4



#5

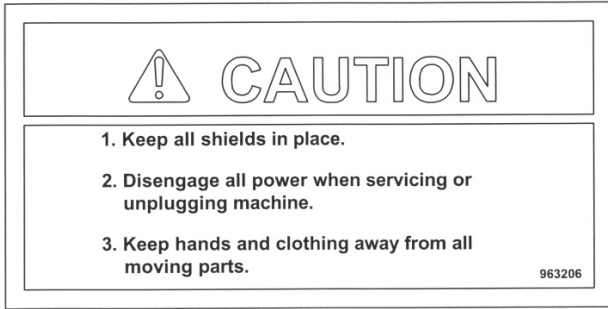

#6

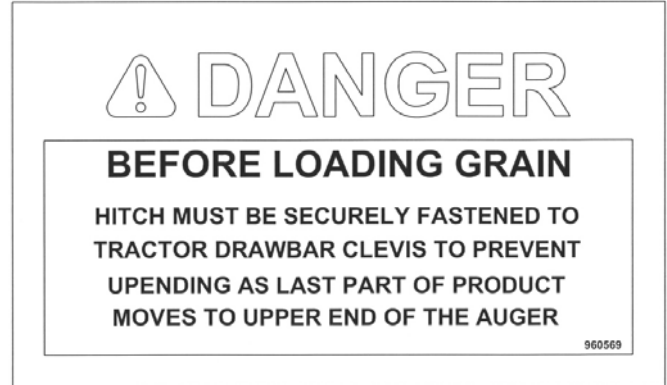

#7



#8

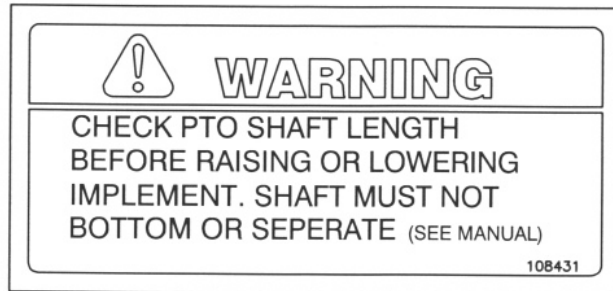

#9

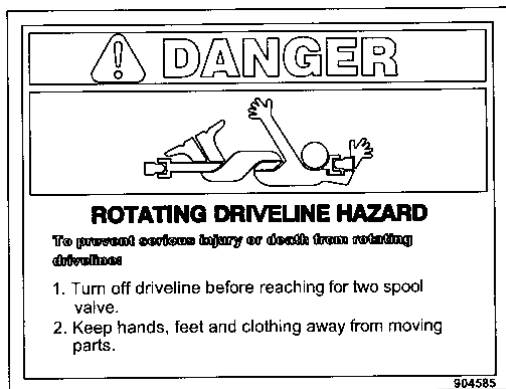

#10



#11

ASSEMBLY INSTRUCTIONS

The assembly of this auger will require a 3-ton overhead crane and a forklift. Many of the components are very heavy so they cannot be maneuvered into place without this equipment.

1. Start the assembly by assembling the entire lift system (pages 32-34). With the axle weldment (#7) turned as shown. Bolt on the stub axles (#58) using 3/4" x 2 1/2" hex bolts, lock washers and hex nuts. Mount the wheel and the tire assemblies (#48) using 5/8" x 2 1/2" wheel bolts. Torque wheel bolts to 160 ft/lbs. (712 N)



ALERT: Do not tighten any hardware for the rest of the lift assembly.

2. Mount the left hand undercarriage arm (#2) to the welded plate on the axle using 3/4" x 2 1/2" hex bolts, lock washers and hex nuts. Next attach the left hand lower lift arm (#9) with a 1 1/4" x 7 1/8" pin (#11) and a 1/4" x 1 3/4" cotter pin.
3. Assemble the two cylinders (#57), the two yokes (#13) and the link weldment (#14). The yoke arm fits against the outside of the link and against the center divider of the link. The cylinder ends fit in the open spaces left in the link. Join parts using a 2" x 18 7/8" pin (#17) and a 5/16" x 3" cotter pin.



ALERT: Cylinder ports should be facing down.

4. Position the cylinder, link arm and yoke assembly up against the left hand lower lift arm. Before attaching the right hand lower lift arm (#10) to the axle. At this point you should lift up the ends of the cylinders until the assembly connecting the lower lift arms is finished. With the cylinders raised, connect the two lower lift arms with the torque tube weldment (#55) using 1/2" x 2" hex bolts, lock washers, flat washers and hex nuts. Add one flat washer on each side. Welded brackets on the torque tube must be turned up.
5. Bolt the cradle rest (#12) to the welded brackets on the torque tube using 5/8" x 3 1/2" hex bolts, lock washers and hex nuts. Connect the yoke, link and cylinder assembly to the bottom of the lower lift using a 2 3/4" x 39" pin (#20). Fit the end of the link between the bottom bushings on the lower lift arms. Insert the pin through the right hand lift arm first, the link second and then the left hand arm. Lock the ends of the pin in place with 1/2" x 3 1/2" bolts, lock washers and hex nuts.
6. Connect the upper lift arm (#8) to the upper bushings on the lower lift arms using 2" x 9 5/8" pins (#21) and 5/16" x 3" cotter pins. These pins must be installed with the head of the pin facing the center of the auger and the cotter pin end facing out. Attach the ends of the yokes to the upper lift arm using a 2" x 20 1/2" pin (#15) and a 5/16" x 3" cotter pin.

ASSEMBLY INSTRUCTIONS – cont'd.

7. Attach the two cylinders to the welded bracket on the upper lift arm using a 2" x 17 1/4" pin (#16) and a 3/16" x 3" cotter pin. Attach the right hand undercarriage arm (#1) at this point. Connect the two undercarriage arms with the brace plate (#5) using 5/8" x 1 3/4" bolts, lock washers and hex nuts.
8. Lift the end of the lift arm assembly slightly above the undercarriage arms. Bolt the lift arm rest tube number 6 to the top surface of the angle irons welded to the inside of the undercarriage arms. Lower the lift arms onto the rest tube. The hardware on the lift assembly will be tightened after the assembly is connected to the tubing and is positioned in place.
9. After the lift assembly is complete, the main tubing is assembled (pages 27-31). Align tubes and assemble tube number 5 to the top of number 4 using 5/8" x 1 3/4" grade 8 hex bolts, 5/8" S.A.E. flat washers and lock nuts. Two side bridging brackets (#18) are bolted to the sides of each pipe ring connection at the same time that the pipe rings are bolted together. Align the flighting with the couplers at the ends and bolt together using a 3/4" x 4" bolt and lock nut. Next, assemble tube number 3 to tube number 2. Finally, bolt tube number 1 to tube number 2.
10. Pages 35-39. Couple the 12 7/8" drive shaft (page 35, #11) to the bottom end of the flighting using a 3/4" x 4" hex bolt and lock nut. Make sure the shaft fits into the 1000 rpm gearbox (#25) before bolting to the flighting. Insert a 3/8" x 7 3/8" key (#12) into the drive shaft and slide the input box assembly (#1) onto the drive shaft. Line up the flange bolt holes on the input box with the pipe ring and bolt together using 5/8" x 1 3/4" grade 8 hex bolts, S.A.E. flat washers and lock nuts. The drive shaft is held on by inserting a 5/8" x 1 3/4" bolt, lock washer and a 1/2" thick x 3" flat washer (#23) at the end of the shaft. Insert splined drive shaft (#79) into the outer coupler on the gearbox and attach PTO shaft (#80).



ALERT: There are two holes on the top stub shaft for cotter pin installation on the top flighting which should allow for a wide range of adjustment.

11. Pages 27-31. Attach all the bridging yokes. The main bridging yoke (#11) bolts to the welded brackets on tube number 2 using 5/8" x 1 3/4" hex bolts, lock washers, flat washers and hex nuts. Attach the two braces (#12) to the main yoke using 1/2" x 1 1/2" hex bolt, lock washers and hex nuts. Tube number 1 has a 74" long yoke (#9) with a 34" brace (#10) bolted on using the same hardware. Tube number 3 uses a 103" long yoke (#13) with a 43" brace (#14) also with the same hardware. The final bridging yoke bolts to tube number 4 which is a 60" long yoke (#16) with a 27 3/4" brace (#17) also using the same hardware.

ASSEMBLY INSTRUCTIONS – cont'd.

12. Pages 27-31. Using an overhead hoist, put a sling around tube number 1 and lift so the bottom end is raised about 12 inches. Attach the shorter top bridging cable first (#75). This cable goes from just below the undercarriage pivot plate on tube number one, across the main bridging yoke and to the top end of tube number 3. Bolt the 2" wide cable yokes (#80) to the top end of each cable using 3/4" x 2 1/2" hex bolts, lock washers and hex nuts. Bolt the yokes to the cable brackets welded to tube number 3 with the same hardware. Use the bottom hole in the yoke if possible. The other holes can be used if the cable stretches after a few years. The long top bridging cable (#76) goes from the lower part of tube number 1, across the main bridging yoke and to the center of tube number 5. Use the same hardware as the short cables. The side bridging cables (#74) run across the four side bridging brackets on each side of the pipe rings from tube number 1 to tube number 5. Use the 1 1/2" wide cable yokes (#81) at the top end of these cables. The hardware for these cables is 1/2" x 1 3/4" hex bolts, lock washers and hex nuts. The top bridging cables are tightened using the threaded rods at the bottom end until the tubes bow up a few inches. Tension the side cable evenly so tubes are straight left and right. Tighten cable clamps after tensioning is complete.



ALERT: On yokes where the cable clamps hold two cables, do not use the cast part of the cable clamp.

13. Put a sling around the tubing at a point just above the main bridging yoke. Raise the top end of the tube assembly high enough to fit the discharge spout (page 28, #79) over the spout opening. Bolt on spout using 3/8" x 1 1/4" hex bolts, lock washers and hex nuts.
14. Tension the flighting using the crown nut at the top of the flighting. Snug up this nut and then give it about an extra 1/4 turn. Do not over tighten. You only want the weight of the flighting to hang from the top bearing.
15. Pages 32-34. Bolt the undercarriage connector plates (#41) to the welded brackets on the sides of tube number 1. Use 5/8" x 1 3/4" hex bolts, lock washer and hex nuts on the top 2 holes. Flat head bolts on the bottom 2 bolts. Lift the tube assembly high enough to roll the lift assembly underneath centered on the tubing. You will need an overhead crane with a 3 ton capacity to lift the tube assembly. The holes at the end of the undercarriage arms must line up with the holes in the connector plates. Slide a 3" OD x 24 1/2" long tube (#3) through all four holes and lock in place with 1 1/2" wide collars (#4), 1/2" x 4 1/2" hex bolts, lock washers and hex nuts. Connect the upper lift arm to the bottom of the main bridging yoke using a 2" x 22 1/2" pin (#18). Lock in place with collars (#19), 1/2" x 3 1/2" hex bolts, lock washers and hex nuts.

ASSEMBLY INSTRUCTIONS – cont'd.

16. Lift up the tubing assembly so lift assembly is a few inches above the cradles. Center the upper lift arm on the cradle. This will require a forklift. Tighten all lift arm and undercarriage hardware while the tube assembly is raised. Lower back into cradle when hardware has all been tightened.
17. Using $3/8"$ x $3/4"$ sq. hd. set screws and a $3/8"$ x $1\ 1/2"$ key mount the u-joint (page 35, #90) on the intake auger gearbox. Position the u-joint by placing a straight edge along the bottom of the pipe ring on the intake auger top box (page 35, #63) and measuring exactly $3"$ from the top of the straight edge to the center of the u-joint as shown in drawing.

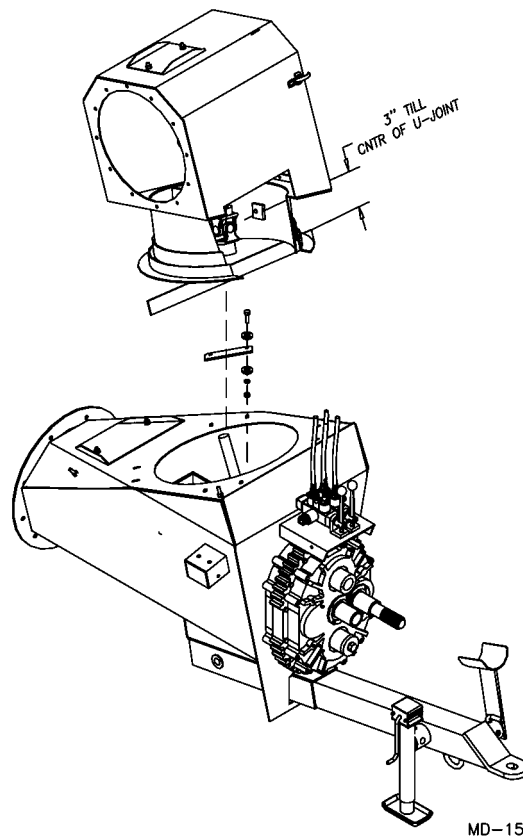

18. Pages 35-39. Lift the intake auger assembly onto the input box (#1). The splines on the U-joint must slide onto the splines on the input box gearbox. This will require a hoist. Let the ring sit on the input box without forcing it to the exact center if it is not positioned perfectly. Flip open the intake auger top door (#73) and bolt on the ring using $3/8"$ x $1\ 1/2"$ hex bolts. A $3/8"$ (10 gauge) flat washer goes under the input box top cover. The $1\ 1/4"$ OD flat washers should be $1/8"$ to $3/16"$ from touching the edge of the ring. This is done to prevent side pressure on the u-joint. Four $2"$ x $6\ 1/2"$ plates (#30) act as a ring holder. Tighten bolts using $3/8"$ lock washers and hex nuts. The intake auger should turn freely around the input box.

ASSEMBLY INSTRUCTIONS – cont'd.

 **ALERT:** If the intake auger is removed for repair or replacement, the bolt coupling the flighting to the intake auger gearbox must be replaced when the flighting is replaced. Not replacing this bolt could cause failure of the hopper flighting.

19. Using a 3/8" x 1 1/2" key and 3/8" x 3/4" sq. hd. set screws, join the hopper flighting and the intake auger flighting at the universal joint (page 36, #45). Join the hopper and intake auger using two 3/4" x 1 5/8" bolts and lock nuts. A flat washer goes on the outside only. Parts must swivel freely after bolting together. Check that the cross on the u-joint is in line with the two pivot bolts.

The cover (page 36, #59) bolts to the front edge of the hopper using 1/4" x 3/4" hex bolts, lock washers and hex nuts. The cover is held down by the cover rod (page 35, #60) which is pushed through the clevises welded to the intake auger and held in place with a 3/16" x 1 1/2" cotter pin. Check that all the set screws on the u-joint have been tightened and that the u-joint has grease before closing the cover.

 **ALERT:** Never run the auger without this cover bolted on. The yoke center must align with the pivot holes after assembly.

20. Pages 36-39. Bolt the 7" wide rubber edging (#55) supplied to the top edge of the hopper using 1/4" x 1" hex bolts, lock washers and hex nuts. Use 1" wide strips on the sides of the hopper (#83) and on the outside edge (#81). These strips fit on the inside of the hopper and help keep the rubber from tearing. The ends of the rubber strips are joined using connector plates (#82, #84) with 1/4" x 1" hex bolts, flat washers, lock washers and hex nuts.
21. The lift boom (page 27, #20) is bolted to a welded bracket on top of tube number 1 about 136" from the bottom pipe ring using 5/8" x 1 1/4" hex bolts, lock washers and hex nuts. The intake auger lift cable (page 22, #82) has a safety hook at one end. Thread the other end of the 3/8" cable around the pulley at the end of the lift boom and then around a cable pulley in the bracket which swivels at the back of the lift boom. Bolt the hydraulic winch (page 22, #86) and solenoid assembly to the welded winch bracket near the bottom of tube number 1 using 1/2" x 2 1/2" hex bolts, flat washers, lock washers and hex nuts. **NOTE:** The end of the lift cable must be run through the winch guard (page 22, #90) before attaching the cable to the winch. Bolt on the winch guard using 1/2" x 1 1/2" hex bolts, lock washers and hex nuts. There are flat irons with two holes welded near the front on the sides of the hopper. Hook the lift cable in the upper hole on the far side of the hopper so the hopper will turn open end toward the auger. This is the standard transport position. The safety chain is attached to the loop at the top end of the hopper. This chain should always be attached when transporting the auger. The lift boom can be used on either side of the auger. The lower hole on the hopper bracket is used for clean out only.

ASSEMBLY INSTRUCTIONS – cont'd.

 **ALERT:** When the intake auger is raised from working position, the lift cable is hooked into the loop at the top of the hopper. The open end of the hook must be turned toward the hopper. The intake auger could detach and fall if the main auger is raised with the hook turned the other way.

22. Pages 40 & 41. The hydraulic line on the auger must be coupled at the pipe rings between tube number 1 and tube number 2 using an 18" hydraulic hose (#21). Screw a 90° elbow (#25) into the ball valve (#26) and connect this assembly to the bottom of the hydraulic line. Attach a 120" hydraulic hose (#24) to this elbow. The other end of the hose connects to the tractor.

23. Connect the 8'-6" hydraulic hose (page 40, #15) with the assembled 12" lines and fittings from the base of the cylinders to the hydraulic line on the main auger. All fittings should be taken apart and sealed with Teflon tape before tightening. Install the two vent plugs (page 32, #42) in the cylinders.

 **ALERT:** The flow control valve (page 40, #16) regulates the lowering of the auger to avoid damage which could be caused by lowering the auger too quickly. Arrow on the flow control should be pointing toward the 6' hose. Be sure that the valve is open approximately 3 1/2 turns before raising the auger to full height or the auger will not lower.

24. Pages 40 & 41. Assemble the fittings into the two spool valve assemblies (#1). There are two #12 MORB to #8 MJIC adaptors (#7) in the side ports. With the valve turned as shown on page 31, fit two #10 MORB to #8 MJIC adaptors (#8) in the right hand ports on top of the valve. The left hand ports which control the mover use adaptors with a restrictor valve (#28).

25. Pages 40 & 41. Assemble the fittings into the hydraulic motors (#10). The upper port on the motor uses a #12 MORB straight adaptor (#7) while the lower port uses a 90° #12 MORB adaptor (#6). The two straight adaptors are joined using a 79" hose (#3). Two 21' hoses (#2) attach to the 90° elbows on the hydraulic motor. They run up between the motor and the hopper and along the intake auger tube to the right side ports, on top of the valve (as shown). These lines are clamped down to the top of the intake auger tube using hose holders (page 35, #28) with 3/8" x 1" hex bolts, lock washers and hex nuts. The hopper mover is controlled by the valve handle which lines up with the two ports the hoses are attached to in the valve.

 **ALERT:** The hopper mover may move quite quickly with some tractors. Be sure everyone is clear of the area when using the mover.

ASSEMBLY INSTRUCTIONS – cont'd.

26. Pages 40 & 41. Attach the 139" hydraulic hoses (#5) to the relief valve (#12) bolted to the winch hydraulic motor. These hoses run down the tube, alongside the input box and connect to the left side ports on the top of the valve. The winch has a pressure relief valve so the hoses must be connected to the correct ports. Check hydraulic system drawing to verify. Two 79" hoses (#4) connect to the sides of the valve. These both attach to the tractor.
27. The relief valve bolted to the winch hydraulic motor should be adjusted before using, if required. The power is adjusted on the control screw on the side of the solenoid valve. The factory setting is 3 turns out. There should be just enough power to lift the empty intake auger off the ground. Remove the plug and adjust with an Allen wrench if required.
- The winch speed is adjusted by a control screw at the end of the solenoid valve. The factory setting is 3 ½ turns out. If speed adjustment is required, loosen the hex nut on the threaded shaft and adjust with an Allen wrench as required. Lock the setting in place with the hex nut.

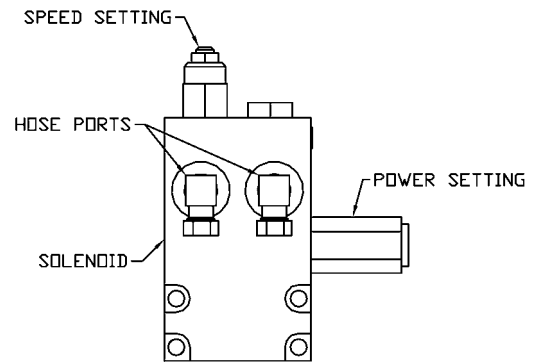

28. The standard drive position for the drive shaft (page 35, #85) in the rpm gearbox (page 35, #26) is in the outer coupler. The center coupler on the gearbox is used to reverse the flighting. This should be used to clean out the auger only. There are two solid plugs in the side of the gearbox. The higher of the two plugs should be removed and replaced with a 90° vent plug (page 50, #17). The lower of the two plugs acts as an oil level plug. MD-20
29. Re-check and tighten all bolts.
30. Immediately after setting up the auger, hook it up to a tractor. Raise and lower the auger three or four times to purge all the air out of the hydraulic line to the lift cylinder. This will help to prevent the auger from settling when you have it in working position above a bin.

⚠️ ALERT: Always check to see that both ends of the PTO shaft are securely attached every time the auger is used. This should always be done with the tractor engine shut off. When transporting the auger, disconnect the PTO shaft from the tractor. The PTO holder at the end of the hitch is used to hold the PTO during transport.

Do not run the auger with the intake auger in the transport position. Doing this will damage the u-joint between the intake auger and the input box.

LIGHT KIT ASSEMBLY

The light kit can be assembled while assembling the auger or it can be added afterwards. The light kit will have to be used in conjunction with the reflective safety decals in some areas. Check local laws to see if this applies in your area. The reflectors and instructions for their placement are in the crate of parts. Always use the light kit when moving the auger on a public roadway.

1. Pages 42 & 43. The main harness (#1) along with the two lines to the halogen lamps (#2 & #3) connect to the two switches (#9) mounted in the switch box welded to the input box. Use a clip (#16) and a 5/16" x 3/4" hex bolts, lock washer and hex nut to fasten the main harness to the side of the valve mount on the input box. The main harness has a 7 pin round end. An adapter (#10) which converts 7 pin round to 7 pin flat is supplied with the light kit. See the wiring schematic for the proper wiring. Hook-up at the switch.
2. Bolt one halogen lamp (#8) to the top box on the intake auger as shown in drawing. Position the lamp so it points at the hopper. Halogen lamps are for use during auger operation only. Switch them off during transport. The harness for the intake auger lamp is clamped on with clip (#15) using the top bolt on the clean out at the top of the intake auger. The other end of the harness connects to the switch as shown in wiring schematic.
3. Bolt the second halogen lamp (#8) to the top end plate on the auger. Bolt cable brackets (#11) to all four sets of pipe rings using the top two bolts on the pipe ring as shown in drawing. Run the 107' wiring harness (#3) from the halogen lamp at the top down to the switch. Clamp the harness to the cable brackets on the pipe rings using clips (#15) with 5/16" x 3/4" hex bolts, lock washers and hex nuts. Pull the bottom end of the harness through the cable brackets and lower bridging stand welded to the bottom auger tube. Connect the bottom end of the harness to the switch as shown in the wiring schematic. A clip (#15) holds the harness at the top of the auger using one of the bolts holding on the top end plate as shown in drawing. Use this lamp for positioning the spout over a bin.
4. The three lines running to the switch box must be fitted through three straw relief connectors (#20) mounted in the switch box bottom plate (#14). Assemble the connectors with accompanying lock nuts (#21) on the three wires before making the final connections. Bolt the bottom plate to the switch box using 5/16" x 3/4" hex bolts and lock washers. Lock the wires in place using the lock nuts which fit onto the connectors.

LIGHT KIT ASSEMBLY – cont'd.

5. Remove the nuts and lock washers from the top two bolts on both undercarriage clamp plates and bolt on the right and left blinker mount weldments (#12 & #13). The ends should face out across the tire. Bolt an amber light (#7) to the top of each mount. The 30" harness (#6) connects to the light on the right hand side as shown in drawing. The two lights are joined by a 13' harness (#5). Use nylon ties to fasten the harness to the axle so it will not hang down. The 45' harness (#4) attaches at the point where the 30" and 13' cables join. Run this wire along the right hand undercarriage and clamp on using nylon ties. Thread the remaining wire through the openings in the cable brackets welded to the side of the auger tube down to the switch box. Connect the end to the main wiring harness

6. Connect the main wiring harness to the towing vehicle and check to see that all lights are working properly. The halogen lamps should turn on and off with the switches. The amber lights should turn on and off with the towing vehicle lights. Use the vehicle flasher if you want the amber lights to flash.

OPERATING INSTRUCTIONS

All augers may be elevated up to 45°; however, for the best operating efficiency 35° should not be exceeded. At angles over 35° the capacity and life of the auger decreases. Use in some types of fertilizer may cause accelerated wear and corrosion as well as added stress on lift components due to additional load. Use in fertilizer can affect warranty.

Run auger partially full until flighting becomes polished.

Never operate an empty auger for over one minute as the flighting and housing will experience excessive wear.

To position the auger, always tow or move the auger in the down position to a point as close as possible to the bin or barn.

 **ALERT:** Always keep the wheels level. Raise the auger to the desired height and back the auger into position. Do not support the auger on the bin. As the auger becomes full it carries a lot of weight and may cause damage to the underside of the auger or to the bin. The auger should be firmly attached to the drawbar of the tractor at all times during operation.

 **ALERT:** Never place blocks under the wheels to increase the elevation of the auger.

Be sure the wheels are free to move and no one is standing close to the auger when raising or lowering. Never attempt to raise or lower the auger while it is in operation.

The intake auger swivels freely on the top of the input box. It can be positioned anywhere between the tractor and the side of the auger.

 **ALERT:** 16" Augers are designed for PTO drive tractors with 1000 rpm only. Maximum capacity will be attained while running the main auger at or near 1000 rpm.

NOTE: The weight of the intake auger and hopper assembly must be supported by the transport chain, whenever the auger is moved. If the weight of the intake auger is on the winch, the winch may be damaged during transport.

The auger uses a hydraulic winch to lift the intake auger. Never have less than three wraps of cable on the drum of the winch.

 **ALERT:** Never operate the hydraulic winch or the hopper mover when the PTO shaft is engaged.

A two-spool valve assembly on the back of the input box controls both the hopper mover and the hydraulic winch. See drawing for proper hose plumbing.

OPERATING INSTRUCTIONS - CONT'D.

⚠ ALERT: Always maintain at least a 4" overlap on the PTO shields. Be sure they turn freely and make certain everyone stands clear of the tractor, PTO shaft, and auger before engaging power take-off. Be sure ends are securely connected to the auger and tractor.

NOTE: TRACTOR HITCH OF LESS THAN 16" MIN WILL RESULT IN PTO BOTTOMING OUT @ MAX HEIGHT. (ASAE STD) TYPE 2 PTO (1 3/8"/1000 RPM) = TRACTOR HITCH DIM OF 16"

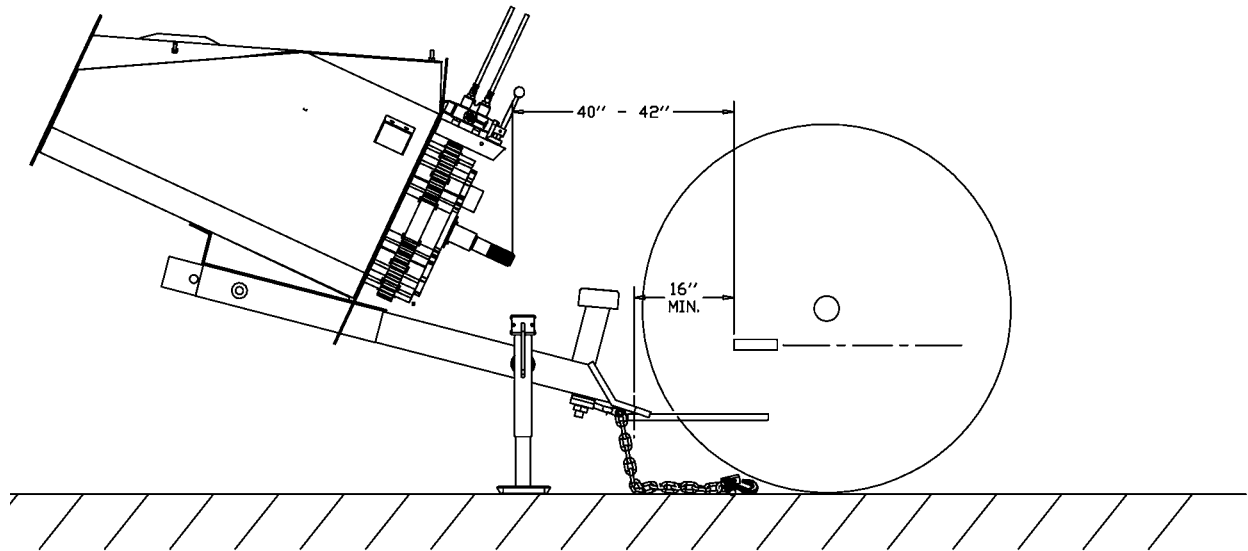

The distance between the tractor and the auger stubs should be between 40" and 42" with the tractor and auger on level ground and the auger in full down position. This distance is obtained by either adjusting the tractor hitch, the auger hitch or both.

Before engaging power take-off, start tractor and idle engine. Engage power take-off slowly and bring PTO rpm up to recommended speed of 1000 rpm for 16" augers.

Before stopping auger (except in an emergency) let all grain empty out of the auger, idle engine then disengage power take-off. Shut off tractor.

⚠ ALERT: Do not use the reverse kit to attempt to unplug the auger. The reverse kit is designed to be used for **CLEAN-OUT ONLY!**

⚠ ALERT: When auger is left in raised position over night, close the ball valve on the hydraulic line to the cylinder. This will prevent the auger from lowering, due to hydraulic leakage, and avoid possible damage.

The hydraulic winch is designed to lift an empty intake auger only. Clean out hopper before attempting to lift with the winch. Do not lift the main auger any higher than 35° before lowering the intake auger. There will be interference between the intake auger and the input box if you go any higher.

OPERATING INSTRUCTIONS - CONT'D.

One-way flow control valve can be adjusted by loosening the hex nut on the side, and turning on the screw with the machined end. Turning the screw in decreases the speed the auger lowers, while turning it out increases the speed. The approximate initial setting should be 3 ½ turns out from the tight position. When set, re-tighten hex nut to set position. **NOTE:** Be sure that the valve is somewhat open before raising the first time or auger will not lower.

Be sure there is always some tension on the flighting by adjusting the end thrust bearing at the upper end of the auger.

 **ALERT:** Always lower auger before transporting and allow the weight of the auger to rest on the undercarriage and not the hydraulic cylinder.

Be certain to turn jack sideways when towing auger.

 **ALERT:** Disconnect the PTO shaft from the tractor and pin it in place in the PTO holder when towing or maneuvering the auger. This will prevent possible damage to the PTO shaft during cornering.

 **ALERT:** If the PTO shaft angle exceeds 50° during a tight turn, the constant velocity joints will be fractured and will likely fail shortly thereafter during operation.

PTO shear bolts (2 required) – 3/8" x 1" hex bolt (grade 8)

 **ALERT:** When towing the auger, never exceed 32 km/h (20 mph).

This 16" auger has a total weight of about 13,000 pounds (5,900 kg) and a hitch weight of about 2,700 pounds (1,225 kg). You must have a vehicle rated for this amount of weight to transport this auger.

THEORY OF OPERATION

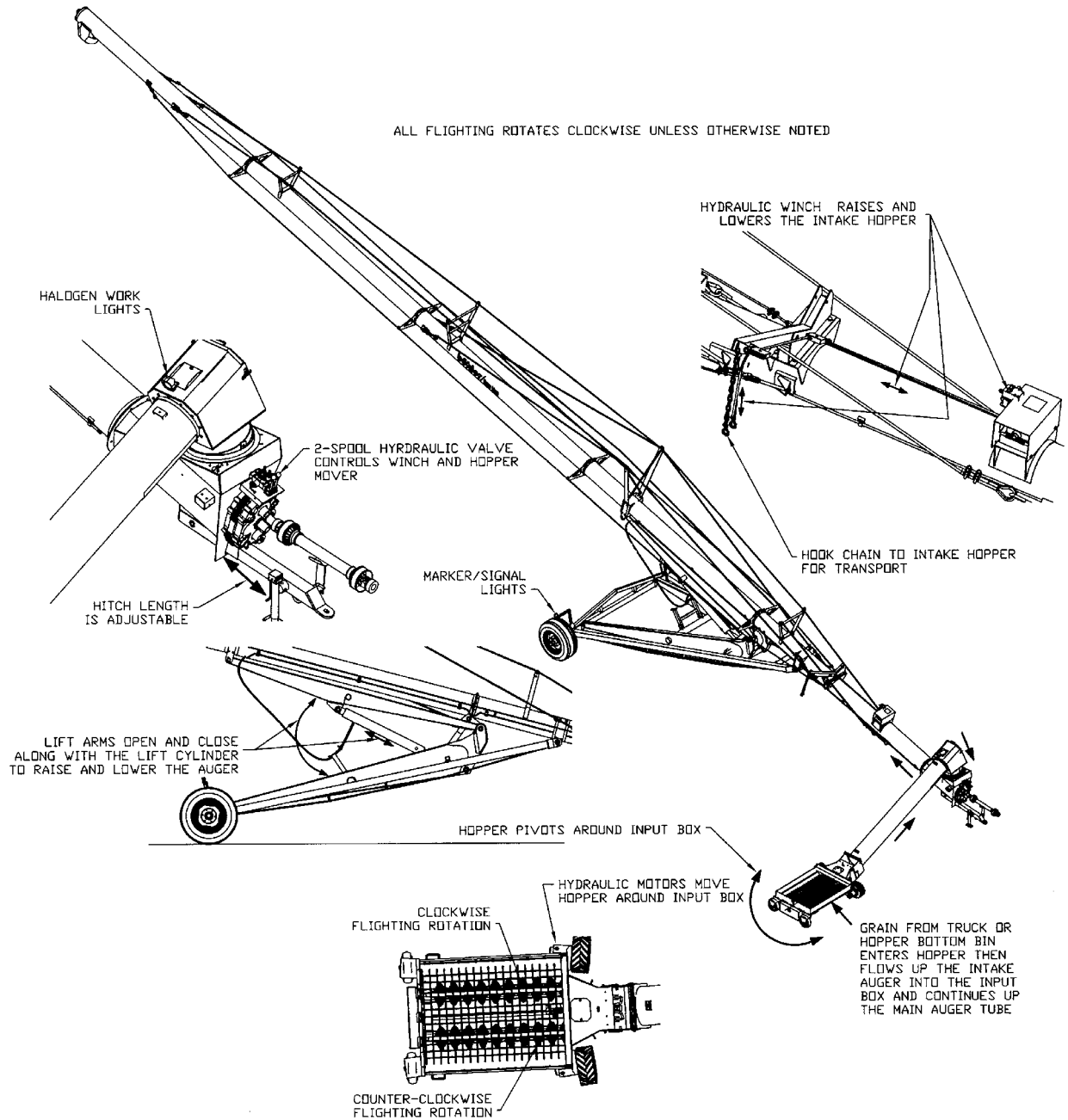

MAINTENANCE & LUBRICATION

Check condition of winch cable regularly. Be sure it is lubricated. Replace cable if you notice any broken strands.

Check to see that there is no downward bow in the main tubes at the start of every augering season. Re-tension cables if required as per the assembly instructions. This should also be checked immediately after hauling the auger for a long distance.

Use a high temperature grease for all lubrication.

Lubricate the PTO shaft as per instruction sheet.

Check grease on end thrust bearing to be sure it is running smoothly and freely. Remove cap and grease at the start of every season.

Check hydraulic lines frequently for leaks or damage.

Grease universal joint in intake auger after every eight hours of use.

Grease the U-joint connecting the two gearboxes about every 8 hours. Do regular checks on the oil level in the gearboxes. Fill if necessary to the height of the side plug using SAE 90 oil. Because the gearbox runs in the grain, it is difficult to see any oil leaks so regular checks should be done. The reducer gearbox requires 2.5 litres of 75W-90 synthetic oil. Reducer gearbox should be serviced every year or every 1000 hours. The hydraulic winch gearbox requires 2.5 litres of 80w-90 gear oil.

 **ALERT:** When replacing bearings or tightening a loose bearing collar, always tighten collar in the direction of shaft rotation using a center punch or a similar tool.

Recommended tire pressure is 45 to 50 psi (max. 60 psi).
310 – 345 kPa (max. 415 kPa)

STORAGE

The auger should be stored in a dry place if possible. If stored outside, lower auger to its lowest position and block up the wheels so auger will not move.

Clean auger thoroughly as dirt draws moisture and causes metal to rust. If the auger has been used to move fertilizer, clean thoroughly and apply oil or grease on entire flighting and inside the housing to stop and prevent further corrosion.

At this time check all moving parts for wear and order replacement parts from your nearest dealer.

When taking the auger out of storage, clean it thoroughly and check for obstructions at the inlet and outlet ends.

Check all bolts and set screws.

Regularly check the tightness of all cable clamps to avoid slipping. Inspect wire rope regularly for evidence of wear or corrosion. Such inspections should take place at progressively shorter intervals over the useful life of the rope, as wear tends to accelerate with use and/or age. Where wear is rapid, the outside of a wire rope will show flattened surfaces in a short time. A piece of cloth or rag, rubbed along the wire rope will help to reveal broken wires. The effects of corrosion are not easy to detect because the exterior wires may appear to be only slightly rusty, and the damaging effects of corrosion may be confined to the hidden inner wires where it cannot be seen. To prevent damage by corrosion, the rope should be kept well lubricated. Periodic cleaning of wire rope by using a stiff brush and kerosene or with compressed air or live steam and relubricating will help to lengthen rope life and reduce abrasion and wear on sheaves and drums.

**RECOMMENDED CUSTOMER GREASING PROCEDURE FOR
50° DOUBLE C.V. PTO**

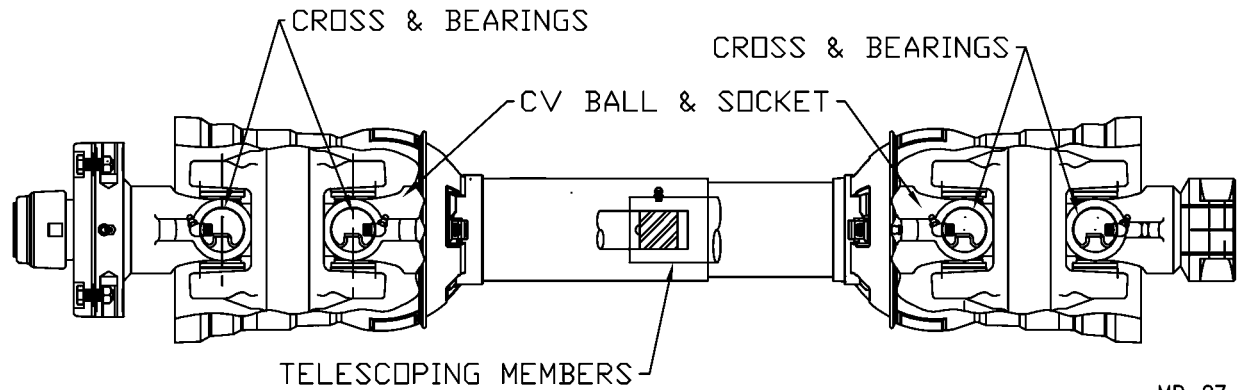



A general purpose grease may be used. However, a grease containing 3% molybdenum disulfide will allow the lube intervals to be extended to twice as long as that listed. The first lube interval should be 16 – 24 hours of operation after initial start-up; then follow the schedule below. Constant angle applications must have a lube interval of 4 hours.

LUBE RECOMMENDATIONS

<u>INTERVAL</u>	<u>LOCATION</u>	<u>AMOUNT</u>
8 hrs.	Cross & Bearings	1 pump
8 hrs.	Telescoping Members	4-8 pumps (until grease comes out of end)
8 hrs.	CV Ball & Socket	1-2 pumps

Greases containing various percentages of moly. are available as extreme pressure greases. Please note that not all E.P. greases contain moly so some investigation may be necessary. The following greases all contain 3% moly: Mobile Oil Company, "Mobile Grease CMP"; Shell Oil Company, "Retinax AM"; and Texaco, "Molytex EP (#0) and (#2)".

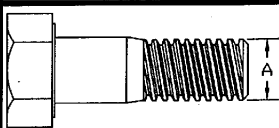
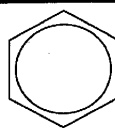
MAINTENANCE

Bolt Torque						
						
Bolt Diameter	SAE2		SAE5		SAE8	
"A"	N.m	lb-ft	N.m	lb-ft	N.m	lb-ft
1/4"	8	6	12	9	17	12
5/16"	13	10	25	19	36	27
3/8"	27	20	45	33	63	45
7/16"	41	30	72	53	100	75
1/2"	61	45	110	80	155	115
9/16"	95	70	155	115	220	165
5/8"	128	95	215	160	305	220
3/4"	225	165	390	290	540	400
7/8"	230	170	570	420	880	650
1"	345	225	850	630	1320	970

TUBE ASSEMBLY

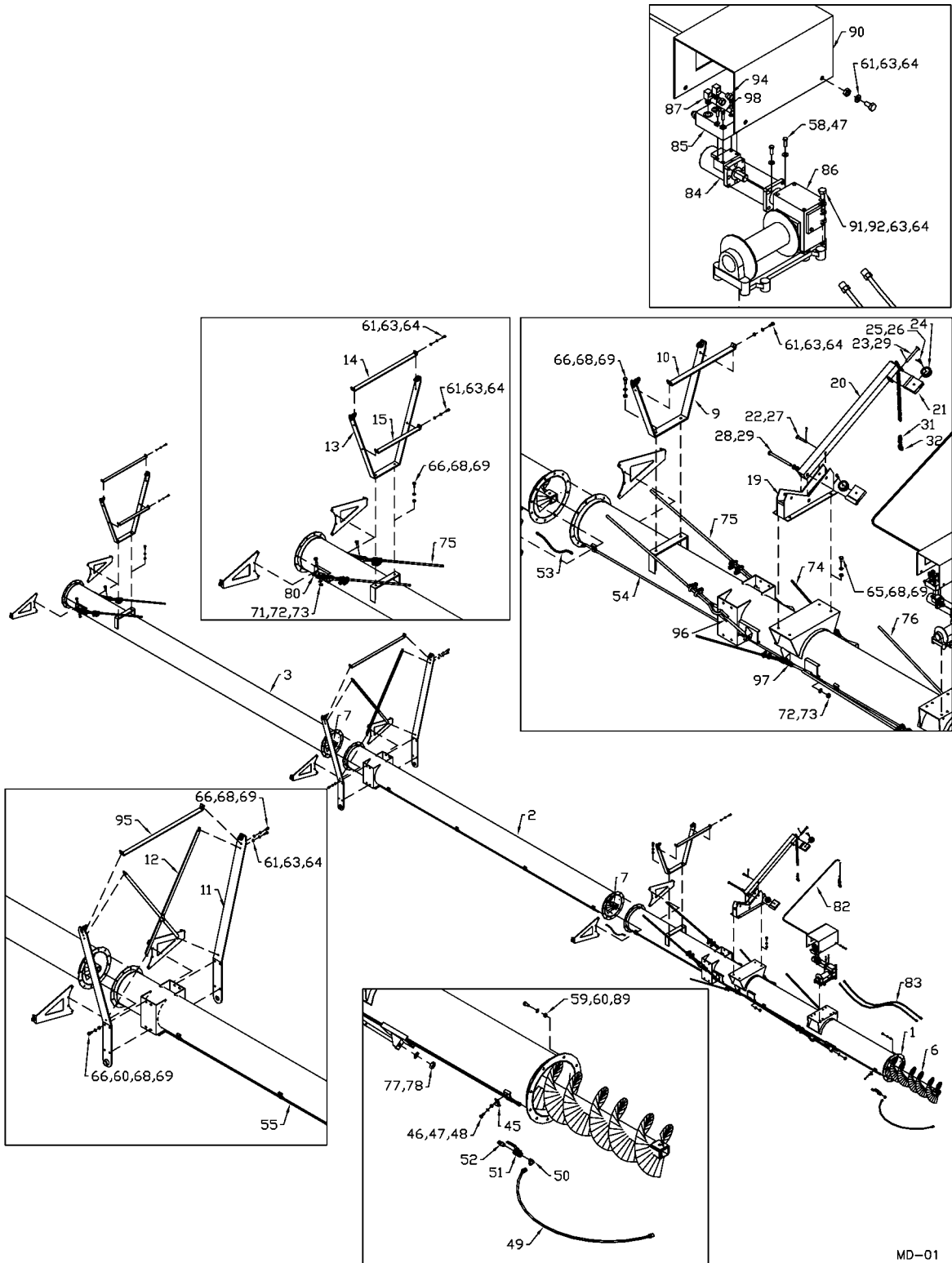

MD-01

WHEN ORDERING PARTS

Always give your dealer the Model, Color and Serial Number of your machine to assist him in ordering and obtaining the correct parts. Use the exploded view and tabular listing of the area of interest to exactly identify the required part.

TUBE ASSEMBLY

Item #	Part #	Description
1	909704	Tube #1
2	909705	Tube #2
3	909706	Tube #3
4	909707	Tube #4
5	909708	Tube #5
6	905760	Flighting Tube #1
7	905763	Flighting Tube #2, 3, & 4
8	905766	Flighting Tube #5
9	905816	Bridging Plate 3" x 74" (Tube #1)
10	905817	Bridging Brace 2" x 34"
11	905826	Bridging Plate 1/2" x 5" x 84 1/2"
12	905827	Bridging Brace 1 5/16" OD x 63"
13	905828	Bridging Plate 3" x 103" Lg (Tube #3)
14	905829	Bridging Brace 2" x 43"
15	905830	Bridging Brace 2" x 31 5/8"
16	905831	Bridging Plate 3" x 60" (Tube #4)
17	905832	Bridging Brace 2" x 27 3/4"
18	906076	Side Bridging Bracket 15 7/16" x 24 7/8"
19	905811	Side Plate
20	905815	Arm Tube 3" Sp. X 45" Lg
21	905819	Pulley Holder
22	905821	Pin 3/4" x 4 1/4" Lg
23	905823	Pin 1" x 6 1/2"
24	961846	Cable Pulley 3 1/2" OD x 1 1/8" W
25	960913	1/2" x 1 13/16" Clevis Pin
26	9812430	1/8" x 1" Cotter Pin
27	961012	Hair Pin Clip #16
28	967233	1" x 10" Hex Bolt
29	84051	1" Jam Nut
30	9812433	3/16" x 1 1/2" Cotter Pin
31	909172	Quick Link 3/8"
32	909171	Hook with Latch (3/4 Ton)
33	906101	Top Plate 16 3/8" OD
34	907052	Oil Seal (CR17617)
35	965252	Inner Bearing Cup (25520)

36	967205	Outer Bearing Cone (25580)
37	905906	End Bearing Sleeve
38	9812445	Washer Narrow Rim 1/5 x 10 Ga (br)
39	907053	1 1/2" Slotted Hex Nut (br)
40	907312	Dust Cap
41	81210	1/4" x 2" Cotter Pin
42	81549	5/16" x 3/4" Hex Bolt
43	81569	5/16" Lock Washer
44	81568	5/16" Hex Nut
45	960140	Hydraulic Line Clamp 1" x 3 1/8"
46	86170	3/8" x 1" Hex Bolt
47	81593	3/8" Lock Washer
48	81592	3/8" Hex Nut
49	967463	1/2" x 120" Hydraulic Hose (Ends Solid &.5" NPT)
50	960585	1/2" x 90° Street Elbow (Stl.)
51	960057	1/2" Ball Valve
52	960152	Adaptor (JIC to 1/2" NPT)
53	960162	1/2" x 18" Hydraulic Hose (Both Ends JIC)
54	906104	Hydraulic Tube 5/8" x 230" Lg (MJIC Both Ends)
55	906105	Hydraulic Tube 5/8"OD x 205" Lg (MJIC Both Ends)
56	964565	1/2" Cable Clamp
57	909194	3/4" Cable Clamp
58	86171	3/8" x 1 1/4" Hex Bolt
59	967285	5/8" x 1 3/4" Hex Bolt (Gr.8)
60	812639	5/8" SAE Flat Washer
61	84277	1/2" x 1 1/2" Hex Bolt
62	87553	1/2" x 1 3/4" Hex Bolt
63	81637	1/2" Lock Washer
64	81636	1/2" Hex Nut
65	811702	5/8" x 1 1/4" Hex Bolt
66	84270	5/8" x 1 3/4" Hex Bolt
67	967287	3/4" x 4" Hex Bolt
68	81677	5/8" Lock Washer
69	81676	5/8" Hex Nut
70	812365	3/4" Lock Nut
71	84346	3/4" x 2 1/2" Hex Bolt
72	81701	3/4" Lock Washer
73	81700	3/4" Hex Nut
74	906045	Side Bridging Cable Assembled 79'
	906044	Side Bridging Cable Only 80'-8"
75	906057	Lower Bridging Cable Assembled 48'
	906056	Lower Bridging Cable Only 49'-8"
76	906059	Upper Bridging Cable Assembled 85'-4"
	906058	Upper Bridging Cable Only 87'-0"

77	81972	7/8" SAE Flat Washer
78	81722	7/8" Hex Nut
79	906130	Discharge Spout
80	905853	Upper Cable Yoke Plate 2" x 10"
81	960244	Side Cable Yoke Plate 1 1/2" x 10"
82	906066	Winch Cable Assembly 3/8" x 40'
83	116849	Hose 1/2" x 11'-6" 1/2" MNPT x 45° 3/4" FJIC
84	971518	Hydraulic Motor 101-1018
85	909169	Release Valve
86	909143	Hydraulic Winch
87	905392	Elbow 3/4" MORB x 3/4" FORB
88	F0678	Flex Spout
89	812482	5/8" Lock Nut (Stl.)
90	909201	Guard Winch 18" x 30"
91	811796	1/2" x 2 1/2" Hex Bolt
92	81638	1/2" Flat Washer
93	907642	Dust Cap Rubber Gasket (ctd#SE49)
94	812079	Adaptor Str. 3/4" MORB x 1/2" SWFNPT
95	909783	Bridging Brace 2" x 51 3/4"
96	906043	Upper Bridging Tightener
97	960613	Side Bridging Tightener
98	967249	5/16" X 2" Socket Head Bolt (br)

LIFT ARM AND UNDERCARRIAGE

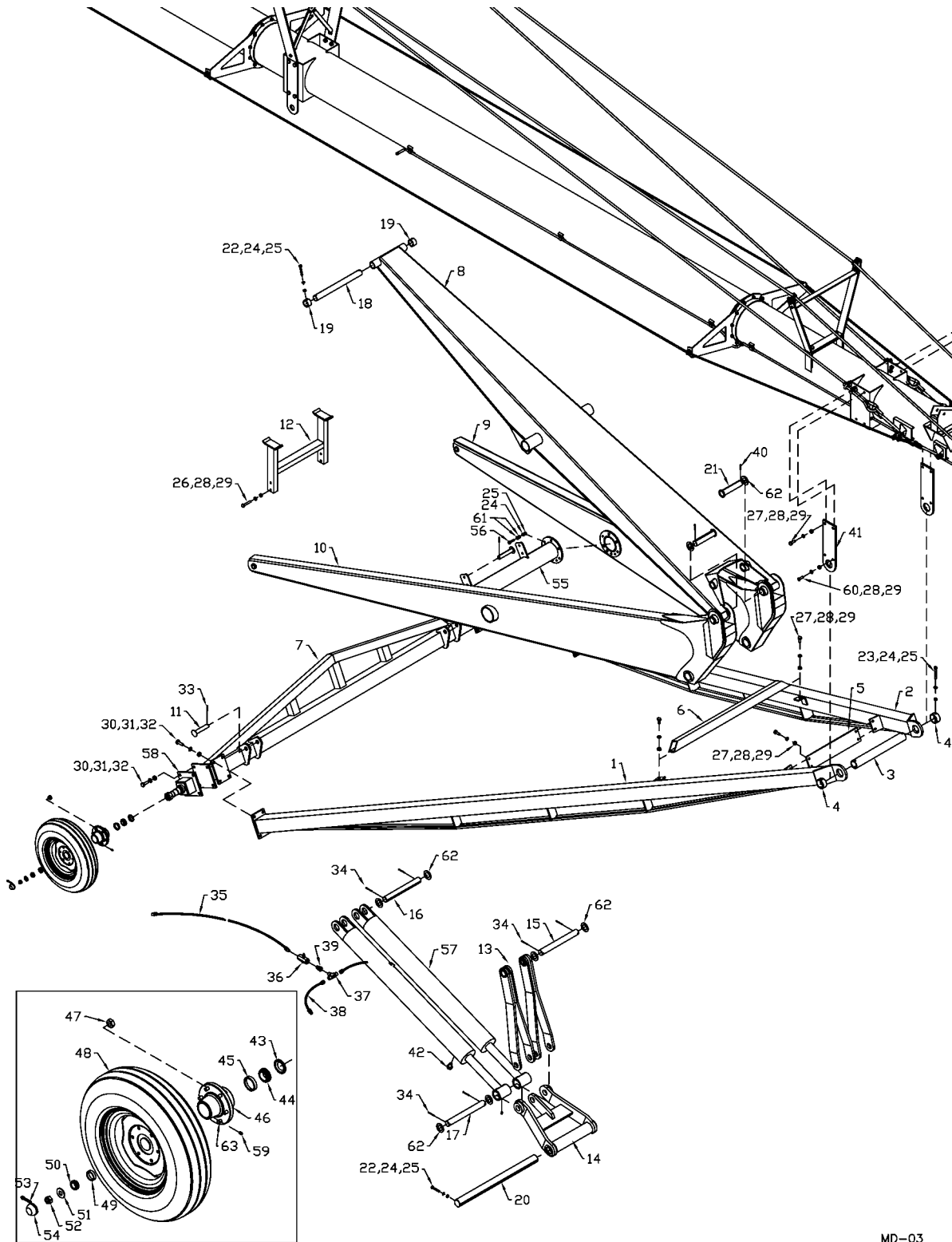

MD-03

LIFT ARM & UNDERCARRIAGE ASSEMBLY

Item #	Part #	Description
1	905732	Undercarriage - R
2	905733	Undercarriage - L
3	905735	Undercarriage Pin 3" OD x 1/4" W x 24 1/2"
4	905736	Undercarriage Pin Sleeve 3 1/2" OD x 1.5" Lg
5	905737	Brace Plate 5" x 25 3/8"
6	905738	Lift Arm Rest Tube 3" Sq x 57 3/4"
7	905745	Axle 5" Sq x 141 1/2"
8	908445	Upper Lift Arm 188.44" Lg
9	F0612	Lower Lift Arm - L
10	F0611	Lower Lift Arm - R
11	905779	Axle Pin 1 1/4" Rd x 7 1/8" Lg
12	905786	Cradle Rest
13	908464	Yoke Arm
14	908472	Link
15	908480	Upper Lift Arm Pin 2" Rd x 20 1/2"
16	908478	Upper Cylinder Pin 2" Rd x 17 1/4" Lg
17	908490	Lift System Link Pin 2" Rd x 18 7/8"
18	905806	Upper Lift Arm Pin 2" Rd x 22 1/2" Lg
19	905807	Upper Lift Arm Pin Collar 2 5/8" OD x 1 1/2" Lg
20	908474	Connecting Link Pin 2 3/4" Rd x 39" Lg
21	908476	Lift Arm Clevis Pin 2" Rd x 9 5/8" Lg
22	81629	1/2" x 3 1/2" Hex Bolt
23	811691	1/2" x 4 1/2" Hex Bolt
24	81637	1/2" Lock Washer
25	81636	1/2" Hex Nut
26	81669	5/8" x 3 1/2" Hex Bolt
27	84270	5/8" x 1 3/4" Hex Bolt
28	81677	5/8" Lock Washer
29	81676	5/8" Hex Nut
30	84346	3/4" x 2 1/2" Hex Bolt
31	81701	3/4" Lock Washer
32	81700	3/4" Hex Nut
33	81210	1/4" x 1 3/4" Cotter Pin
34	967162	5/16" x 3" Cotter Pin
35	116938	1/2" X 8'-6" Hydraulic Hose (1/2" NPT; JIC)
36	960118	Flow Control Valve
37	865341	Tee 7/8" SWFJIC x 7/8" MJIC
38	906103	Hydraulic Hose 1/2" x 12" (3/4" MORB; 1/2" FNPT)
39	960152	Adaptor str. 7/8" MJIC To 1/2" Pipe MNPT
40	967162	5/16" x 3" Cotter Pin

41	904736	Undercarriage Connector Plate
42	967908	3/4 - 16 ORB Vent Plug
43	909184	Oil Seal
44	909185	Inner Bearing Cone
45	909188	Inner Bearing Cup
46	909186	Hub w/ Bearing Cups (8-Bolt)
47	909779	5/8" Wheel Nut NF (16")
48	909182	Wheel 14" x 16.1" x 8
	909181	Tire - 16.5L - 16.1Fi
	F0679	Wheel & Tire Assembly
49	909189	Outer Bearing Cup
50	91024	Outer Bearing Cone
51	9812442	1 1/4" x 10 Ga Narrow Rim Washer (br)
52	960037	1 1/4" Slotted Hex Nut Gr. 2 (br)
53	967252	3/16" x 2 1/2" Cotter Pin
54	909192	Dust Cap CTD #DC26
55	907741	Torque Tube 6" OD x 53" Lg
56	811791	1/2" x 2" Hex Bolt
57	F0664	Cylinder 5.00 x 55.35 W/ 3 1/2" Shaft
58	906109	Bolt On Stub Axle (8-Bolt)
59	967900	1/4" Grease Fitting
60	967284	5/8" x 1 3/4" Fl Hd Skt Bolt
61	81638	1/2" Flat Washer Std.
62	967153	2" x 10 Ga Narrow Rim Washer
63	909839	Wheel Stud 5/8" NF

INTAKE SYSTEM ASSEMBLY

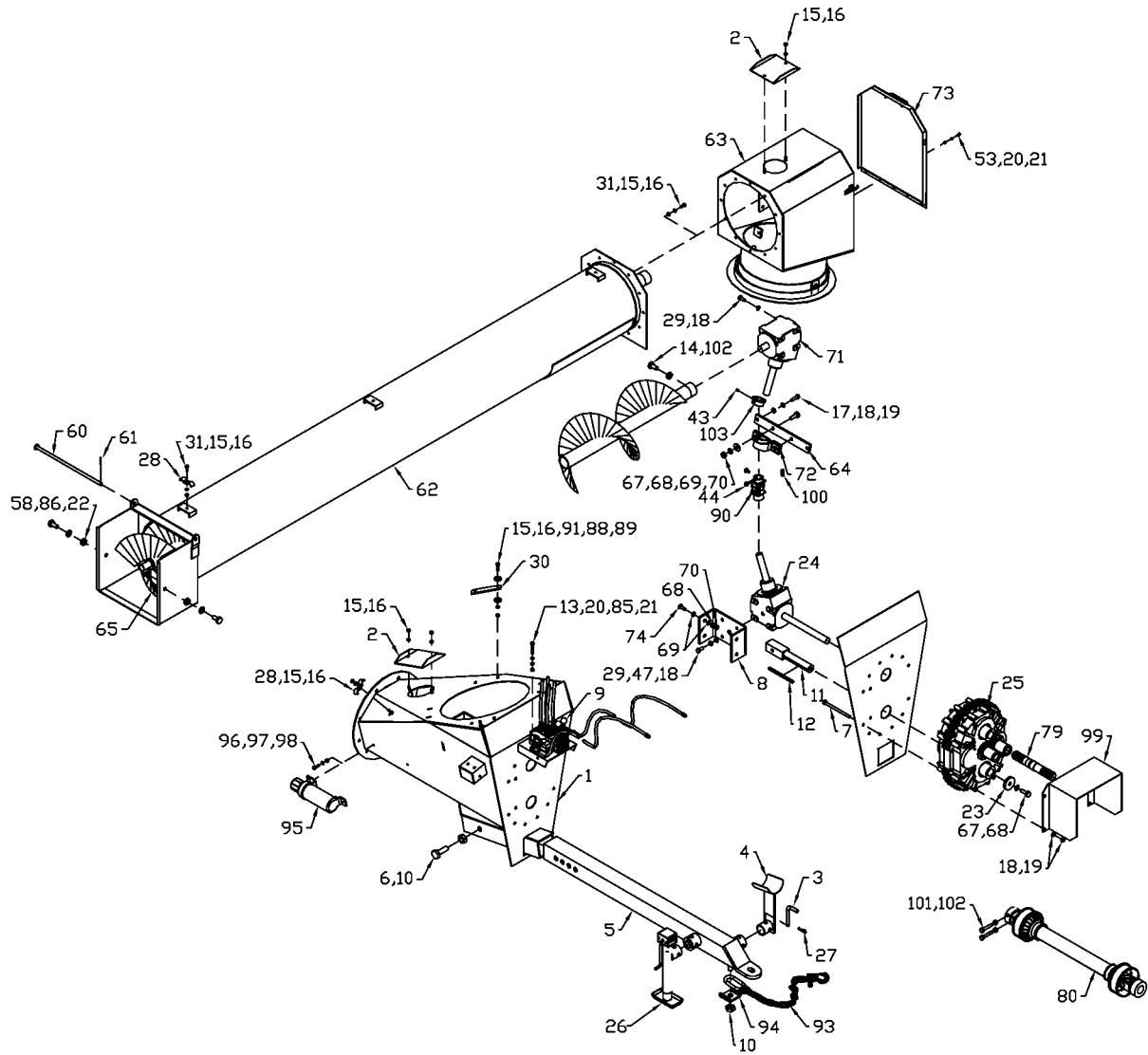

MD-04

INTAKE SYSTEM ASSEMBLY

Item #	Part #	Description
1	909641	Input Box
	905873	Clean-Out Lid
2	960483	Intake Auger & Input Box Clean Out Lid
3	9108493	PTO Holder Pin 5/8" x 7 7/8"
4	905879	PTO Hold
5	905887	Hitch
6	967229	1" x 6" Hex Bolt
7	811835	1/2" x 9" Hex Bolt
8	909837	Gearbox Mount Plate 7" x 18 1/2"
9	909983	Valve Assembly - Two Spool
10	967148	1" Lock Nut
11	905900	Drive Shaft 2" x 12 7/8" Lg
12	906061	Drive Key 3/8" Sq x 7 3/8" Lg
13	967193	1/4" x 2 1/2" Hex Bolt
14	910025	1/2" x 4" Hex Bolt Grade 8
15	81593	3/8" Lock Washer
16	81592	3/8" Hex Nut
17	87553	1/2" x 1 3/4" Hex Bolt
18	81637	1/2" Lock Washer
19	81636	1/2" Hex Nut
20	81545	1/4" Lock Washer
21	81544	1/4" Hex Nut
22	812365	3/4" Lock Nut
23	906073	Washer 1/2" x 3" x 21 /32" ID
24	905882	Input Box Gearbox
25	909827	1000 rpm Box
26	909195	Jack
27	12779	#9 Hair Pin Clip
28	964638	Hose Holder 1" x 4 1/4"
29	81620	1/2" x 1 1/4" Hex Bolt
30	960653	Box Ring Clamp 2" x 6 1/2"
31	86170	3/8" x 1" Hex Bolt
32	905973	Hopper
33	905980	Outer Flighting
34	906063	Center Drive Shaft 1 1/2" x 59 7/8" Lg
35	905988	Center Flighting Shaft
36	906003	Rear Center Flighting Holder Assembly
37	906007	Outer Flighting Holder Assembly
38	960705	Key 3/8" Sq x 1 3/4" Lg
39	906021	Key 3/8" Sq x 2 5/8" Lg
40	968627	Bearing 1 1/2" with Collar
41	967260	Bearing Flange (80mm-SQ)

42	960719	Sprocket 15T 1 1/2" Bore #80
43	988999	3/8" x 3/8" Setscrew Scktser (br)
44	9812378	3/8" x 3/4" Setscrew Sqhead (br)
45	907282	U-Joint 1 1/2" Both Ends with 3/8" Keyway
46	84277	1/2" x 1 1/2" Hex Bolt
47	84048	1/2" Flat Washer
48	906011	Hopper Chain Guard Cover
49	905364	Top Clean Out Cover
50	906042	Chain #80 x 34 Pitches Includes Connector
51	909180	Flat Washer 2" OD x 13/32" ID x 7 Ga
52	909193	Hydraulic Motor 169-0093-001
53	81525	1/4" x 3/4" Hex Bolt
54	810958	1/4" x 2 1/4" Hex Bolt
55	906018	1/4" Rubber Edge 7" x 82 1/2"
56	966851	13" x 5.00" x 6" Tire with Wheel
57	902615	3/4" x 7" Bolt Axle
58	967437	3/4" x 1 5/8" Hex Bolt
59	906015	Pivot Cover 12" x 20 1/4"
60	906017	Pivot Cover Pin 5/8" x 20"
61	12780	#7 Hair Pin Clip
62	905919	Intake Auger Tube
63	909644	Intake Auger Top Box
64	905928	Bearing Holder Plate 2" x 16 1/2"
65	905949	Flighting 156 1/16" Lg
66	81527	1/4" x 1" Hex Bolt
67	84270	5/8" x 1 3/4" Hex Bolt
68	81677	5/8" Lock Washer
69	812639	5/8" Flat Washer
70	81676	5/8" Hex Nut
71	905881	Intake Auger Gearbox
72	905951	Bearing & Flange 1 3/4" Wooden
	909740	1 3/4" Wooden Bearing Only
73	905937	Intake Auger Door
74	84299	5/8" x 2" Hex Bolt
75	909179	Power Mover Wheel Hub
76	960800	Tire with Wheel 16 x 6.5 x 8 4-Bolt
77	968404	1/2" x 1 1/4" NF Wheel Bolt
78	967105	1/2" Lock Nut (NF)
79	906629	Drive Shaft 1 3/4" x 12" (Splined)
80	F0680	PTO Shaft 2 x CV 20/21 Splines
81	906019	Back Rubber Reinforcement 1" x 13"
82	960834	Back Center Rubber Reinforcement 1" x 5"
83	960660	Rubber Reinforcement 1" x 57 1/4"
84	903483	Rubber Connector Plates

85	81546	1/4" Flat Washer
86	84050	3/4" Flat Washer (SAE)
87	905999	Center Flighting Holder Assembly
88	964001	3/8" Flat Washer
89	960494	1 1/4" OD x 13/32" ID Washer
90	905788	U-Joint 1 3/4" Bore Both Ends 8 1/2" Lg
91	811792	3/8" x 1 1/2" Hex Bolt
92	905769	Key 3/8" Sq x 1 1/2" Lg
93	906284	Hook & Safety Chain Assembly
94	904580	Safety Chain Plate 3/8" x 3" x 5 1/2"
95	909277	Manual Holder
96	81549	5/16" x 3/4" Hex Bolt
97	81569	5/16" Lock Washer
98	81568	5/16" Hex Nut
99	909454	PTO Guard 10 3/8" x 38"
100	909294	Key 3/8" Sq x 1 1/4" Lg
101	81626	1/2" x 2 3/4" Hex Bolt
102	812364	1/2" Lock Nut
103	909466	Hub 3" OD x 1 1/4" Lg

HYDRAULICS

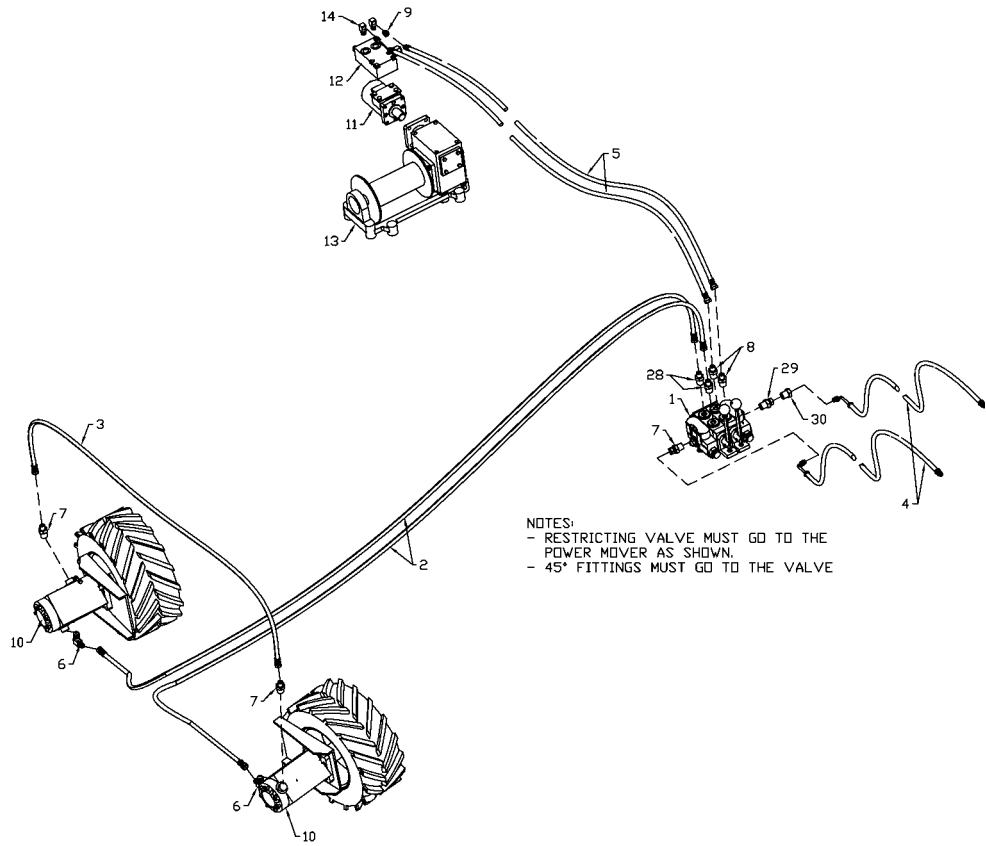

- NOTES:
 - RESTRICTING VALVE MUST GO TO THE POWER MOVER AS SHOWN.
 - 45° FITTINGS MUST GO TO THE VALVE

MD-18

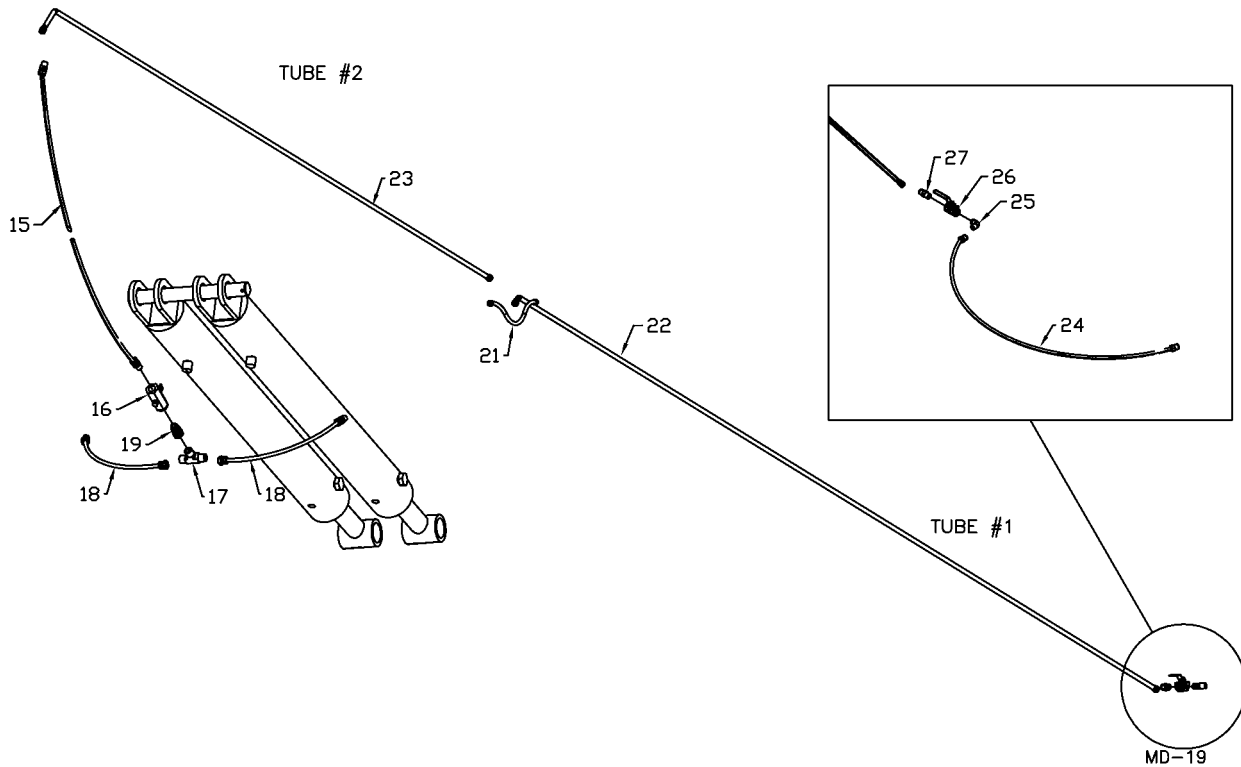

HYDRAULICS

Item #	Part #	Description
1	909983	Hydraulic Valve Assembly - 2 Spool
2	116850	Hydraulic Hose 1/2" x 21'-0" (3/4" FJIC x 45° 3/4" FJIC)
3	116851	Hydraulic Hose 1/2" x 79" (3/4" FJIC Both Ends)
4	116848	Hydraulic Hose 1/2" x 79" (1/2"MNPTx90° 3/4"MJIC)
5	116849	Hydraulic Hose 1/2" x 139" (1/2"MNPTx45° 3/4" FJIC)
6	811960	Elbow 90° (1 1/16" MORB to 3/4" MJIC)
7	811748	Adaptor Str. (1 1/16" MORB to 3/4" MJIC)
8	886897	Adaptor Str. (7/8" MORB to 3/4" FJIC) (Top Of Valve - To Hydraulic Winch)
9	812079	Adaptor Str. 3/4" MORB x 1/2" SWFNPT
10	909193	Hydraulic Motor 169-0093-001 - Power Mover
11	971518	Hydraulic Motor 101-1018
12	909169	Relief Valve
13	909143	Hydraulic Winch
14	905392	Elbow 90° (3/4" MORB x 3/4" FORB)
15	116938	1/2" X 8'-6" Hydraulic Hose (1/2" NPT; JIC)
16	960118	Flow Control Valve
17	865341	Tee 7/8" SWFJIC x 7/8" MJIC
18	906103	1/2" x 12" Hyd Hose (3/4" MORB;1/2" FNPT)
19	960152	Adaptor str. 1/2" MNPT x 7/8" MJIC
20	F0664	Cylinder 5.00 x 55.35 W/ 3 1/2" Shaft
21	960162	1/2" x 18" Hydraulic Hose (Both Ends JIC)
22	906104	Hyd Tube 5/8" x 230" Lg w/ MJIC Both Ends
23	906105	Hyd Tube 5/8" OD x 162" Lg w/ MJIC Both Ends
24	967463	1/2" x 120" Hd. Hose (Both Ends Solids &1/2" NPT)
25	960585	1/2" x 90° Street Elbow (Stl.)
26	960057	1/2" Ball Valve
27	960152	Adaptor (JIC to 1/2" NPT)
28	909460	Adaptor Str. Restricting (7/8" MORB to 3/4" MJIC) (Top of Valve - To Power Mover)
29	909936	Adaptor Str. (#12 MORB to #8 FORB)
30	909935	Check Valve (Flow #8 MORB to #8 MJIC)

LIGHT KIT

MAIN HARNESS - 9' LG

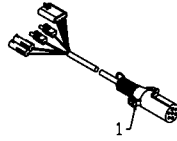

ADAPTOR - 7 PIN RD TO 7 PIN FLAT

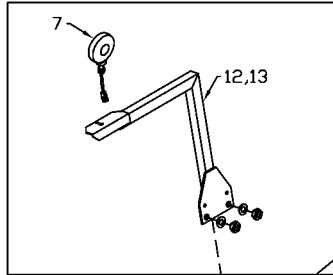
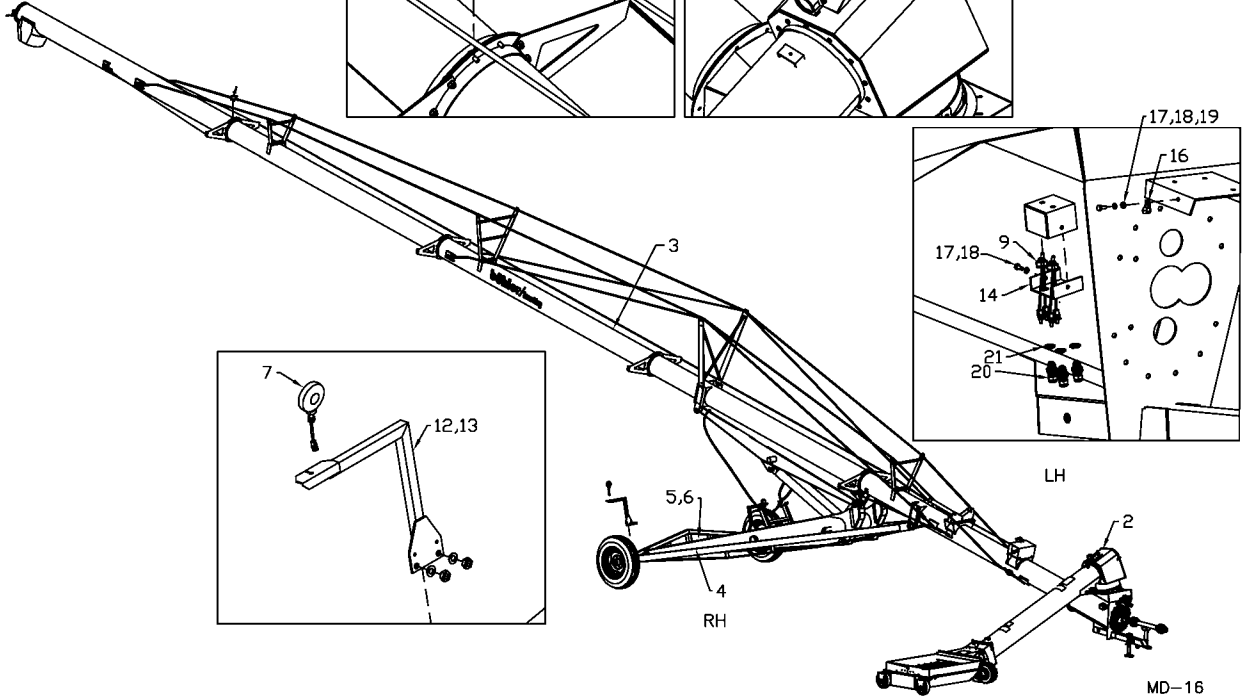
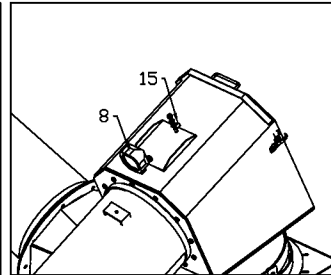
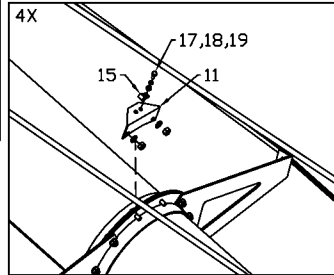
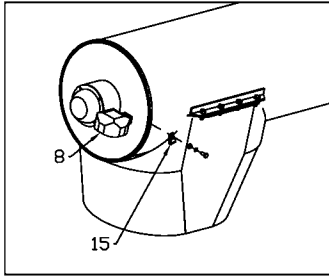
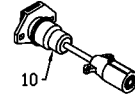

LIGHT KIT WIRING SCHEMATIC

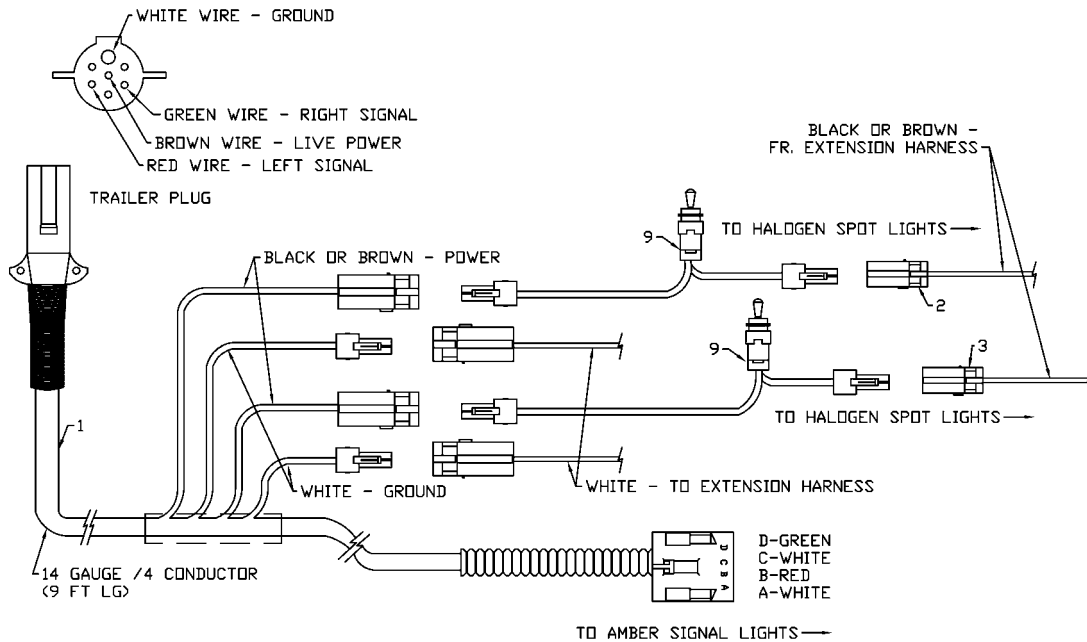

MD-17

LIGHT KIT (F0697)

Item #	Part #	Description
Light & Harness Kit (909209)		
1	909414	Main Harness, 9'-0" lg
2	909415	Ext. Harness to Halogen Lamp, 5'-6" lg
3	909416	Ext. Harness to Halogen Lamp, 107'-0" lg
4	909417	Main Extension Harness To Amber Lamps, 45'-0" lg
5	909418	Ext. Harness #1 to Amber Lamp - 13'-0"
6	909419	Ext. Harness #2 to Amber Lamp, 2'-6" lg
7	909420	Amber Lamp
8	909421	Halogen Lamp
9	909422	Switch - Weather Proof
10	909423	Adaptor, 7 Pin Rd to 7 Pin Flat
Brackets & Mounts		
11	909219	Cable Bracket 4 25/32" x 6"
12	909226	Blinker Mount Weld't - Rh
13	909227	Blinker Mount Weld't - Lh
14	909231	Light Switch Box Btm Pl 4" x 7 1/2"
15	JDCAH77279	Clip
16	JDCAH78237	Clip, Plastisol
17	81549	5/16" x 3/4" Hex Bolt (pl)
18	81569	5/16" Lock Washer (pl)
19	81568	5/16" Hex Bolt (pl)
20	908916	1/2" Strain Relief Connector
21	909427	Lock Nut, Strain Relief Connector

Cylinder F0664

Item #	Part #	Description
	F0664	
1	25123	5.0 Dia. Head plate
2	116817	Shaft Weldment 3.5 OD x 70.00 Lg
3	25329	5.0 Dia. Tube Weld't
4	116818	5.0 Dia. Piston
5	87557	Locknut 1.25 UNF
6	82425	O-Ring 4.50 ID x 5.00 OD x 0.085
7	83425	Backup 4.50 ID x 5.00 OD x 0.085
8	82214	O-Ring 1.00 ID x 1.25 OD Buna
9	115130	U-Cup 4.25 OD x 3.50 ID x 0.375
10	115129	Wiper Seal 3.50 ID x 4.00 OD x 0.25
11	812081	Plug 3/4 MORB Steel
12	22370	Hydraulic Cylinder Decal
13	105420	Reference Plate JBI/FK Serial #
14	116129	Stop Tube 6.00 Lg
15	814406	Wear Ring 5.00 OD x 4.75 ID x 0.500 W

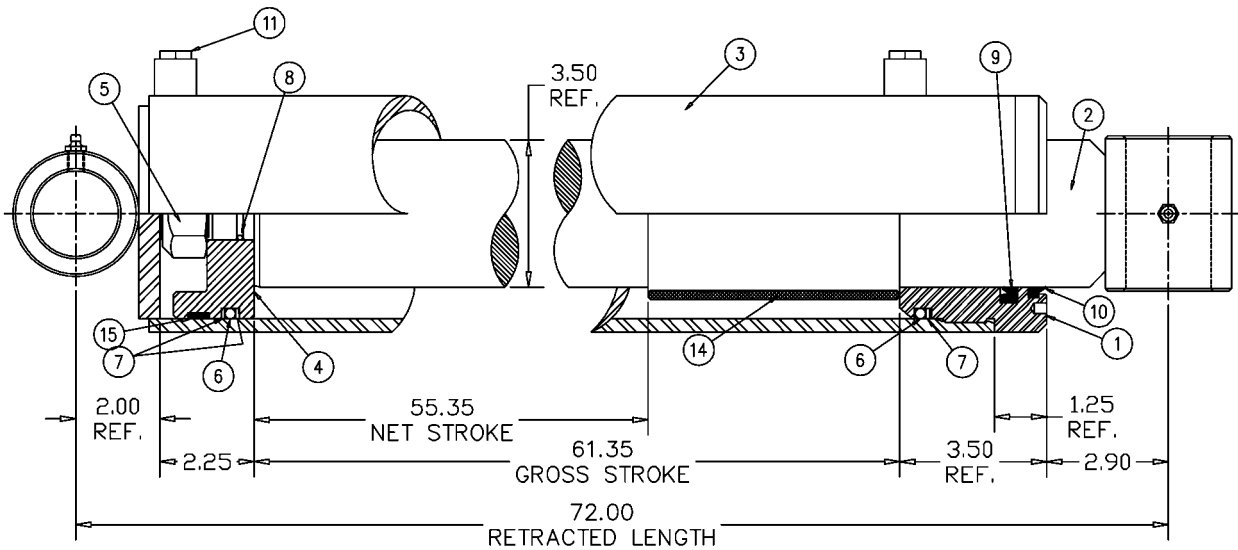

MD-08

PTO F0680

Item #	Part #	Description
	F0680	Shaft Complete
	909354	Joint & Shaft Half - Tractor
	909355	Joint & Tube Half - Implement
1	936433	SSL/Auto-Lock Repair Kit
2	967270	Bolt, .375-16 x 1.00 Lg., Gr. 8
3	812363	Lock Nut, .375-16
4	909358	Ball Shear ASM.
5	906505	55E Cross & Bearing Kit
6	936436	Center Housing
7	909359	Yoke & Shaft (1.31 Square)
8	908844	Guard Repair Kit
9	909360	Safety Sign
10	909361	Outer Guard
11	909362	Inner Guard
12	909363	Safety Sign (Not Shown)
13	909364	Yoke, Tube & Slip Sleeve
14	909365	Yoke

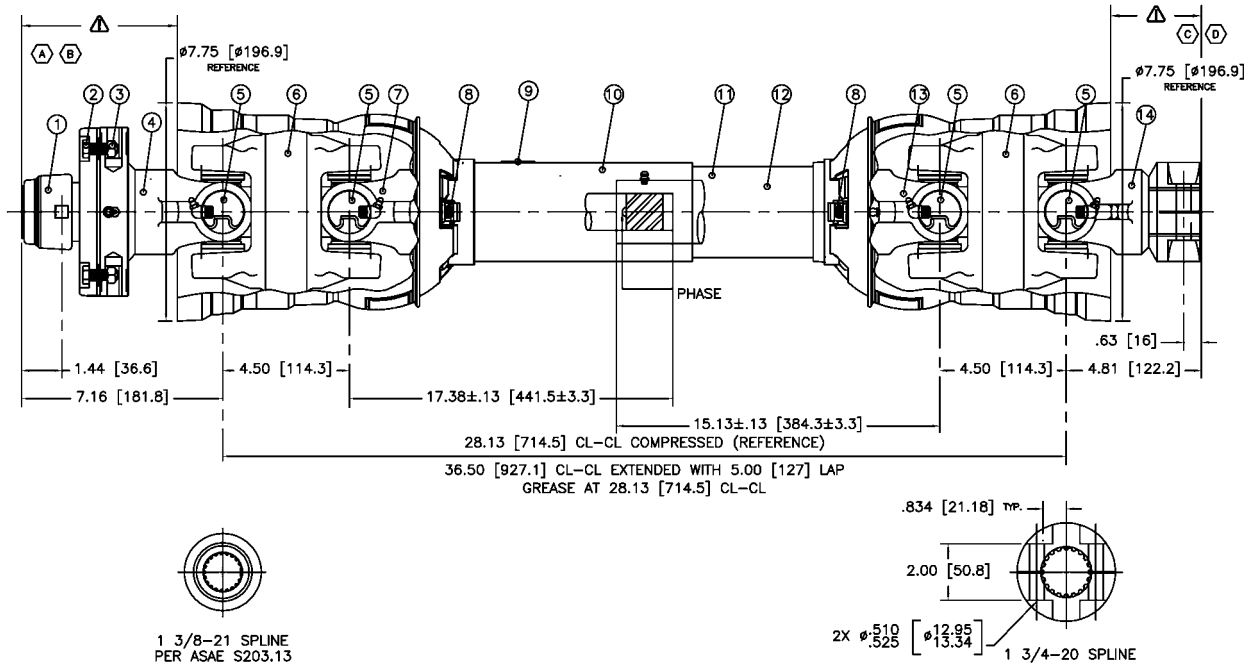

MD-09

INTAKE AUGER GEARBOX (905881)

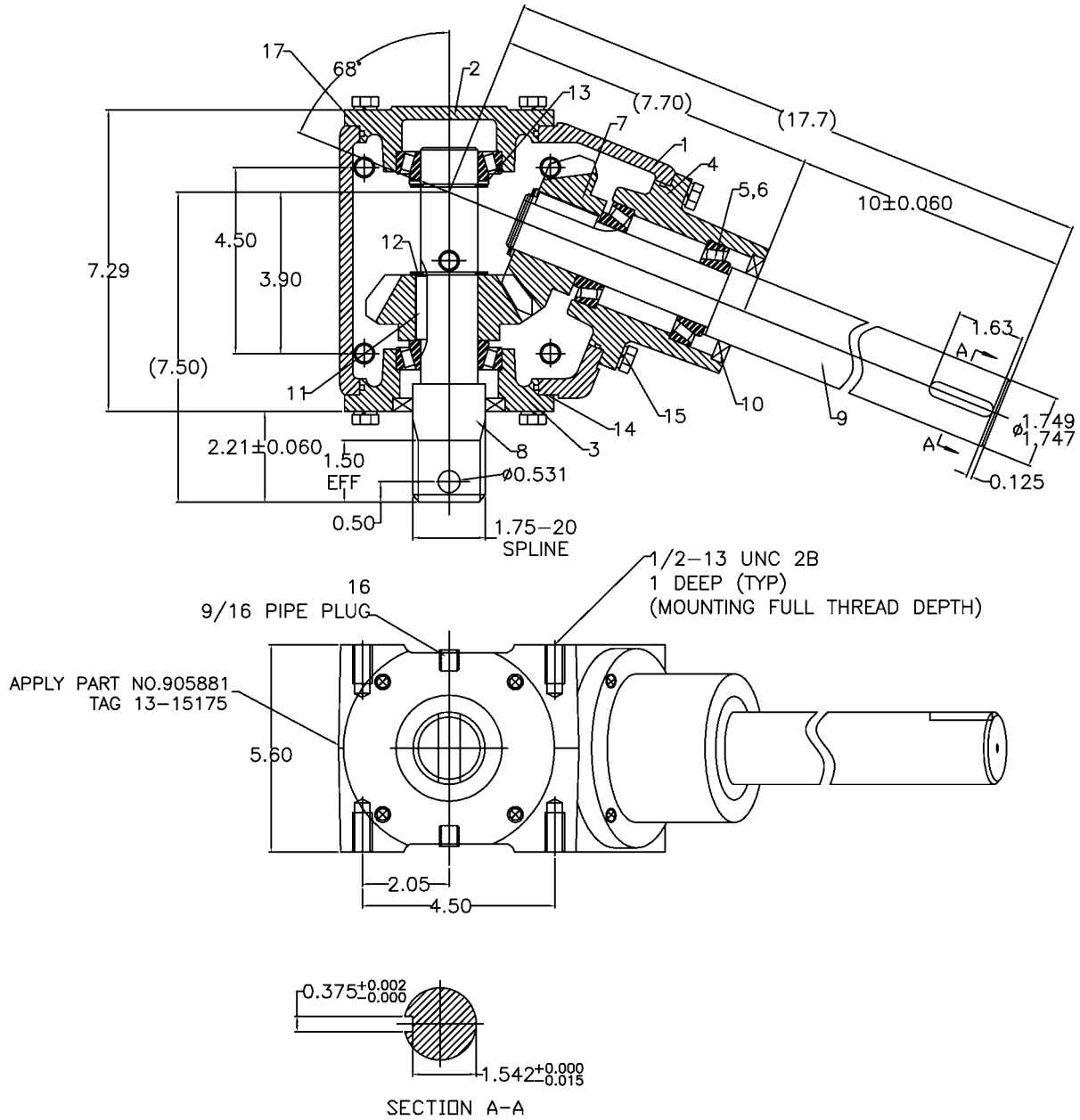

Intake Auger Gearbox (905881)

Item #	Part #	Description
	905881	Complete Gearbox
1	960803	Housing
2	960805	End Cap
3	909366	End Cap
4	909367	Quill
5	967208	Bearing Cone LM48548
6	968412	Bearing Cup LM48510
7	960812	Gear, DP 4.23 Teeth 17
8	909368	Shaft, Cross
9	909369	Shaft, Quill
10	909370	Seal, (1.75 x 2.717x0.315)
11	960821	Square Key, 5/16" x 1.61"
12	960809	Snap Ring
13	960808	Spacer
14	960815	Gasket
15	960814	Capscrew, 3/8"-16UNC x 1.00"
16	960818	9/16" Pipe Plug w/ O-Ring
17	908895	O-Ring, 105mm x 3.1

INPUT BOX GEARBOX (905882)

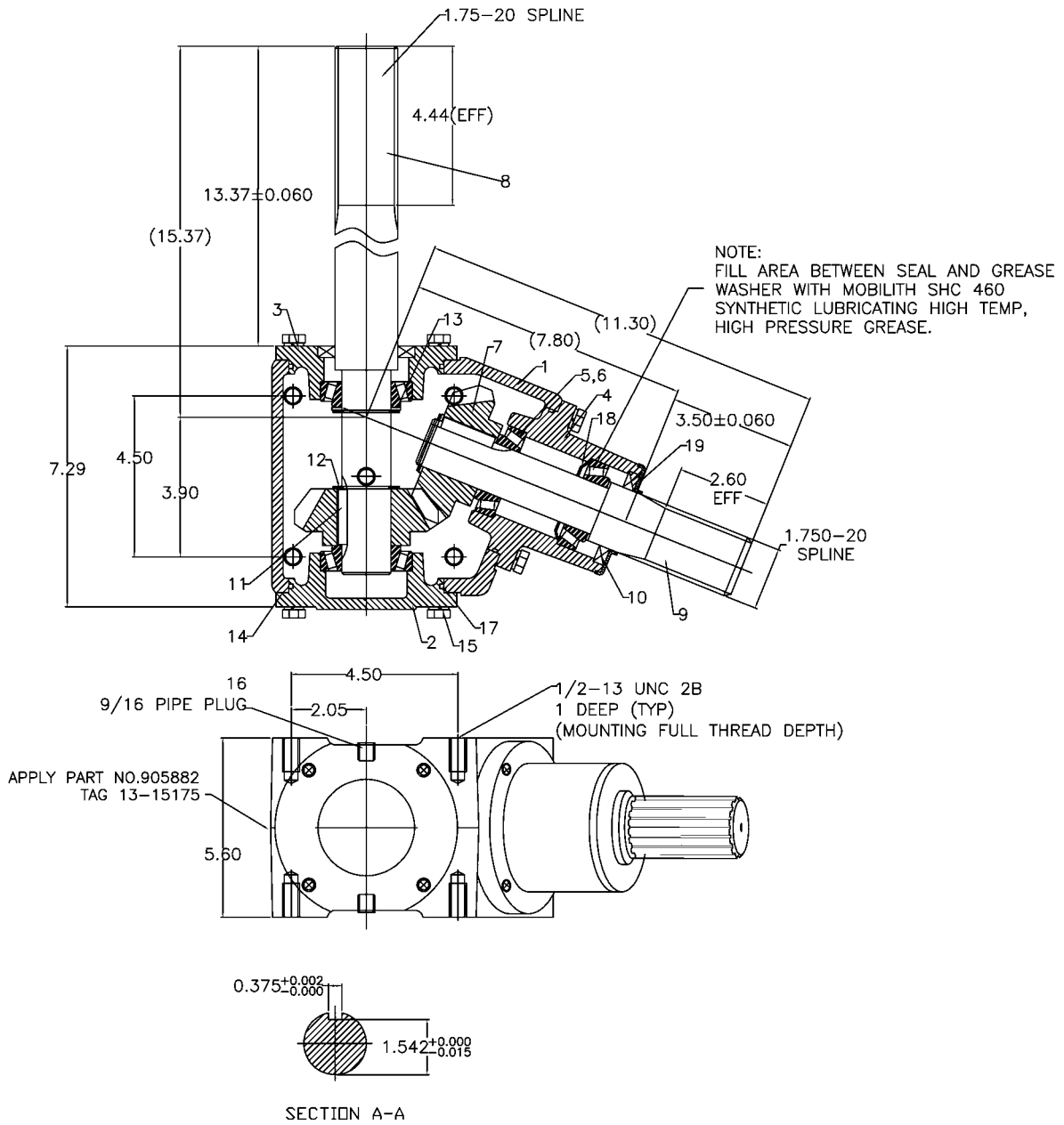

MD-11

Input Box Gearbox (905882)

Item #	Part #	Description
	905882	Complete Gearbox
1	960803	Housing
2	960805	End Cap
3	909366	End Cap
4	909367	Quill
5	967208	Bearing Cone LM48548
6	968412	Bearing Cup LM48510
7	960812	Gear, DP 4.23 Teeth 17
8	909371	Shaft, Cross
9	909372	Shaft, Quill
10	909370	Seal, (1.75 x 2.717x0.315)
11	960821	Square Key, 5/16" x 1.61"
12	960809	Snap Ring
13	960808	Spacer
14	960815	Gasket
15	960814	Capscrew, 3/8"-16UNC x 1.00"
16	960818	9/16" Pipe Plug w/ O-Ring
17	908895	O-Ring, 105mm x 3.1
18	960824	Grease Washer
19	909373	Shield

1000 rpm GEARBOX (909827)

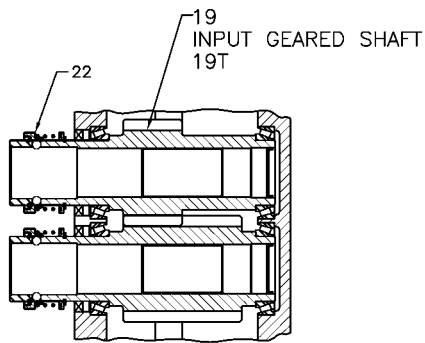
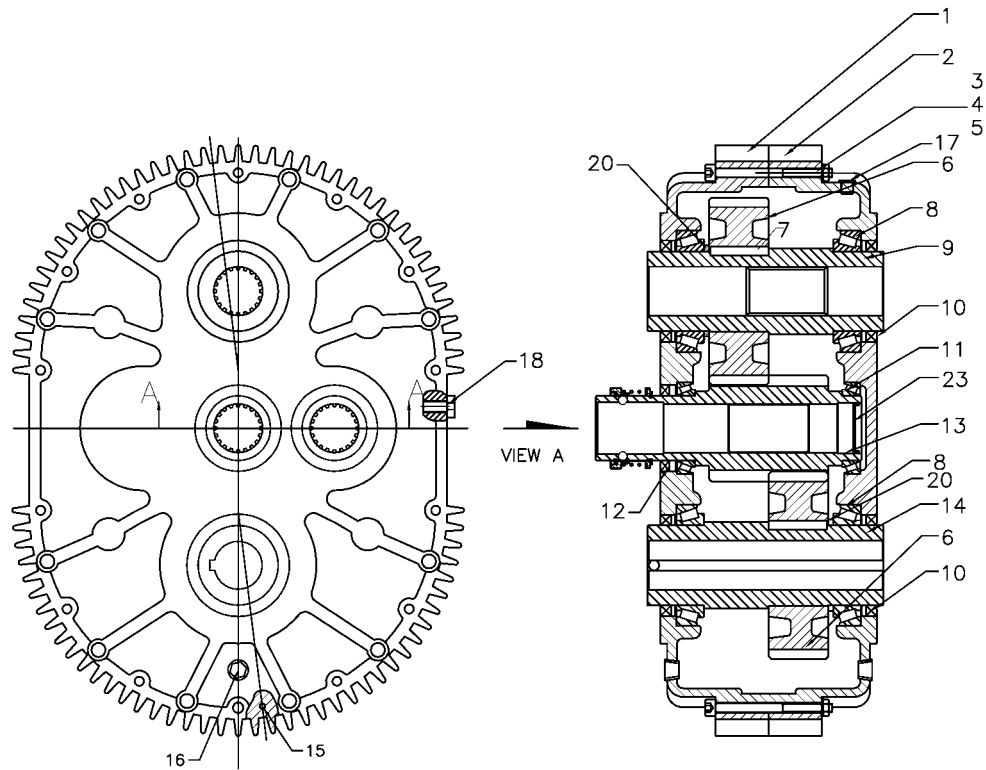

SECTION A-A

MD-12

1000 rpm Gearbox (909827)

Item #	Part #	Description
	909827	Complete Gearbox
1	909388	Front Housing
2	910028	Back Housing
3	909390	Bolt M8 x 110
4	909391	Washer M8 x 1mm
5	909392	Nut M8 x 1
6	909828	Output Gear M4.5 35 T
7	909979	Key 12 x 8 x 49
8	909829	Bearing 32015
9	909830	Output Shaft W/Splines
10	909831	Oil Seal 95 x 75 x 10
11	909398	Bearing 32912
12	909399	Oil Seal 60 x 80 x 10
13	909844	Idler Sleeve 19T
14	909832	Output Shaft W/Keyway
15	909402	Pin 5 Dia x 30
16	909833	Pipe Plug 3/4"
17	910029	Vent Plug 3/8"
18	909405	Pipe Plug 3/8"
19	909845	Input Shaft 19T
20	909407	Spacer
21	909409	Capscrew, 5/16"-18UNC
22	909825	Locking Collar
23	909981	Stamping Cover

INTAKE LIFT – HYDRAULIC WINCH (909143)

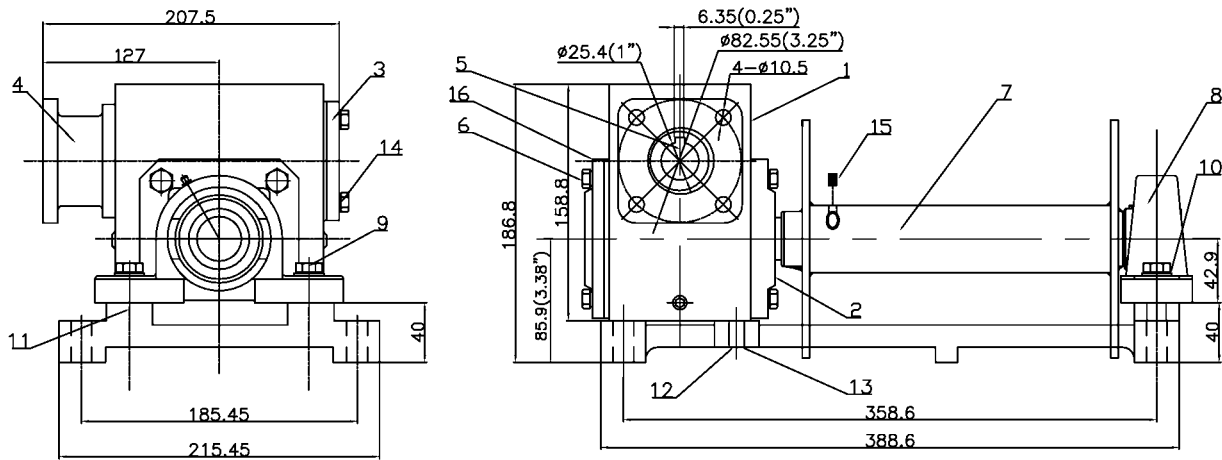

MD-13

INTAKE LIFT HYDRAULIC WINCH (909143)

Item #	Part #	Description
	909143	Complete Winch
1	909374	Housing
2	909375	Output Cap
3	909376	Input Cap
4	909377	Input Flange
5	909378	Worm
6	909379	Bolts
7	909380	Output Shaft
8	909381	Bearing
9	909382	Bolt
10	909383	Washer
11	909384	Base
12	909385	Bolt
13	909386	Washer
14	909387	Bolt
15	967050	3/8" x 1/4" Socket Setscrew
16	909581	Input Cap

SHIPPING KIT AND BUNDLE NUMBERS

The following is a list of Kit Numbers for this product and the Bundle Numbers, Descriptions, and Quantities for each Kit.

QUANTITY	BUNDLE NO.	DESCRIPTION
Y16104 16" x 104' BACKSAVER AUGER		
1	F0808	Intake Auger Assembly
1	F0109	Multi-flighting Hopper Assembly
1	F0807	Input Box
1	F0934	Crate of Parts
1	F0846	Tube #1 Assembly
1	F0847	Tube #2 Assembly
1	F0850	Tube #5 Assembly
1	F0848	Tube #3 Assembly
1	F0849	Tube #4 Assembly
1	F0611	Lower Lift Right
1	F0612	Lower Lift Left
2	F0679	Wheel and Tire Assembly
1	905732	Undercarriage Left
1	905733	Undercarriage Right
1	905745	Axle
1	908445	Upper Lift Arm

NOTES

DIVISION LOCATIONS

Farm King Division
301 Mountain Street S.
Morden, MB R6M 1X7
Ph.: (204) 822-4467
Fax: (204) 822-6348

Allied/Inland Division
1260 Clarence Avenue
Winnipeg, MB R3T 1T2
Ph.: (204) 284-6100
Fax: (204) 477-2325

B.I.I. Division
1330 43rd Street N.W.
Fargo, ND 58102
Ph: (701) 282-7014
Fax: (701) 282-5865

U.S. WAREHOUSES

AR, West Memphis
(870) 732-3132

GA, Stone Mountain
(770) 908-9439

ID, Meridian
(208) 887-6006

IN, Clarksville
(812) 284-3376

KS, Wichita
(316) 265-9577

MN, Lakeville
(952) 469-5267

MT, Billings
(406) 248-7771

ND, Bismarck
(701) 223-1886

ND, Fargo
(701) 282-7003

NE, Blair
(402) 426-8211

OH, Youngstown
(330) 793-0862

OR, Beaverton
(503) 641-1865

SD, Huron
(605) 352-8616

TX, Houston
(713) 928-2632

UT, Salt Lake City
(801) 972-4321

WI, Portage
(608) 742-1370

CANADIAN WAREHOUSES

B.C., Abbotsford
(604) 864-2665

AB, Edmonton
(780) 962-6991

SK, Regina
(306) 781-2300

ON, Woodstock
(519) 539-0435

QC, Dorion
(450) 455-4840

OFFSHORE WAREHOUSES

Burando Hill
Katanning
W. Australia
011-618-98-214422

Chihuahua, Mexico
011-52-158-90306

John Kerr Equipment Ltd.
Wilcoxholm Farm
Linlithgow, W. Lothian
Scotland
011-441-506-842280

Skovde, Sweden
011-46-500-452651

Naestved, Denmark
011-45-557-29511

bühler

Buhler Manufacturing

**301 Mountain Street S.
Morden MB.
R6M 1X7
Ph.: (204) 822-4467
Fax: (204) 822-6348
www.buhler.com**