

bühler

farm king



10" Backsaver Auger

Operator's and Parts Manual
FK306

2009

TABLE OF CONTENTS

DESCRIPTION	PAGE
WARRANTY	1
INTRODUCTION	2
SAFETY	3
Safety	3
General Safety	4
Start Up Safety	4
Operation Safety	4
Transport Safety	5
Service and Maintenance Safety	5
Storage Safety	6
Safety Signs	6
Safety Sign Installation	6
ASSEMBLY	10
Assembly Instructions	10
10" x 10' Auger Extension–Assembly Instructions..	16
OPERATION	17
Operating Instructions	17
Theory of Operation	20
MAINTENANCE	21
Maintenance & Lubrication	21
Storage	21
Greasing Procedure	22
Bolt Torque	23
PARTS DRAWINGS	24
Auger Drawings	24
Top Feed Hydraulic Drawing	27
Auger Parts List	28
Reverse Kit Drawing & Parts List	35
Multi-Flighting Hopper Drawing & Parts List	36
Extension Parts List	38
Cylinder Drawings and Parts Lists	39
PTO Shaft Drawing & Parts List	42
Reverse Option PTO Shaft Drawing & Parts List ...	44
Input Box Gearbox Drawing & Parts List	46
Intake Box Gearbox Drawing & Parts List	48
Winch Drawing	50
Winch Parts List	51
SHIPPING KIT AND BUNDLE NUMBERS	52

WARRANTY POLICY

Buhler Manufacturing products are warranted for a period of twelve (12) months (90 days for commercial application) from original date of purchase, by original purchaser, to be free from defects in material and workmanship under correct, normal agricultural use and proper applications.

Buhler Manufacturing's obligations under this warranty shall be limited to the repair or exchange, at Buhler Manufacturing's option, of any Buhler Manufacturing product or part which proves to be defective as provided. Buhler Manufacturing reserves the right to either inspect the product at the buyer's location or have it returned to the factory for inspection.

The above warranty does not extend to goods damaged or subject to accident, abuse or misuse after shipment from Buhler Manufacturing's factory, nor to goods altered or repaired by anyone other than an authorized Buhler Manufacturing representative.

Buhler Manufacturing makes no Express Warranties other than those which are specifically described. Any description of goods, including any references and specifications in catalogues, circulars and other written material published, is for the sole purpose of identifying goods and shall conform to such descriptions. Any sample or model is for illustrative purposes only and does not create an Express Warranty that the goods conform to sample or model shown.

The purchaser is solely responsible for determining suitability of goods sold. This warranty is expressly in lieu of all other warranties expressed or implied. Buhler Manufacturing will in no event be liable for any incidental or consequential damages whatsoever. Nor for any sum in excess of the price received for the goods for which liability is claimed.

WARRANTY CLAIMS:

Warranty requests must be prepared on Buhler Manufacturing Warranty Claim Forms with all requested information properly completed. Warranty Claims must be submitted within a thirty (30) day period from date of failure repair.

WARRANTY LABOR:

Any labor subject to warranty **must** be authorized by Buhler Manufacturing. The labor rate for replacing defective parts, where applicable, will be credited at 100% of the dealer's posted shop rate. Defective parts will receive an extra 10% discount to assist with freight or other incidental costs.

GOVERNMENT LEGISLATION:

Warranty terms and conditions are subject to Provincial or State legislation.

IMPORTANT FACTS:

Buckets and Bucket Tines Carry No Warranty
Bent Spears Carry No Warranty
Snowblower Fan Shafts Carry No Warranty
Mower Blades Carry No Warranty
Portable Auger Parts Have Two (2) Year Warranty
Loader Parts Have Two (2) Year Warranty

IMPORTANT NOTE:

This warranty does not apply to rentals.

INTRODUCTION

Buhler Farm King gives you more choices to match your auger to your bins, power sources and operating convenience. The superior scissor lift system features a one way hydraulic cylinder with a restrictor valve to control the rate of descent in the event of hydraulic hose failure. This feature is safer than conventional cable systems. Also, note the extra wide undercarriage and wheel tread providing better stability at greater heights, particularly in windy conditions. The unique mechanical linkage is designed to use less hydraulic pressure to lift the auger, even when fully loaded. The pivoting Hopper Lift Arm may be flipped over for left or right transport position. Slip the PTO from the main shaft onto the optional reverse kit for complete cleanout. An adjustable arm holds the PTO shaft when not in use. The hitch is adjustable for various tractor hitch lengths.

The shut off valve is designed to keep your auger in the position you set it. The cross auger is driven by two internal gearboxes. These assemblies are easily reached for service. Because of the large input and intake boxes, capacity is not restricted. The standard self leveling hopper on all Backsaver augers stays flat on the ground, even when the auger is raised up to a high bin. The optional double auger hopper is 2.5" (63.5mm) lower than the standard self-leveling hopper and has a hinged cover for easy servicing. An optional 2-wheel power mover allows you to move the hopper back and forth with fingertip control.

Other advanced features include a tapered thrust bearing at the top of the auger, torqued to remove pressure on the bottom end bearing.

Keep this manual handy for frequent reference. All new operators or owners must review the manual before using the equipment and at least annually thereafter. Contact your Buhler Dealer if you need assistance, information, or additional copies of the manual. Visit our website at www.buhler.com for a complete list of dealers in your area. The directions left, right, front and rear, as mentioned throughout this manual, are as seen facing in the direction of travel of the implement.

SAFETY INSTRUCTIONS

Remember, YOU are the key to safety. Good safety practices not only protect you, but also the people around you. Make these practices a working part of your safety program. Be certain that everyone operating this equipment is familiar with the recommended operating and maintenance procedures and follows all the safety precautions. Most accidents can be prevented. Do not risk injury or death by ignoring good safety practices.

The alert symbol is used throughout this manual. It indicates attention is required and identifies hazards. Follow the recommended precautions.



The safety alert symbol means...

ATTENTION! BECOME ALERT! YOUR SAFETY IS INVOLVED!



CAUTION

The caution symbol indicates a potentially hazardous situation that, if not avoided, may result in minor or moderate injury. It may also be used to alert against unsafe practices.



WARNING

The Warning Symbol indicates a potentially hazardous situation that, if not avoided, could result in death or serious injury, and includes hazards that are exposed when guards are removed. It may also be used to alert against unsafe practices.



DANGER

The Danger Symbol indicates an imminently hazardous situation that, if not avoided will result in death or serious injury. This signal word is to be limited to the most extreme situations, typically for machine components that, for functional purposes, cannot be guarded.

GENERAL SAFETY INSTRUCTIONS

Have a first-aid kit available for use and know how to use it.

Have a fire extinguisher available, stored in a highly visible location, and know how to use it.

Wear appropriate protective gear. This list may include but is not limited to:

- Hard hat
- Protective shoes with slip resistant soles
- Protective glasses or goggles
- Heavy gloves
- Wet weather gear
- Hearing protection
- Respirator or filter mask

Read and understand the Operator's Manual and all safety signs before operating, servicing, adjusting, repairing, or unplugging the equipment.

Do not attempt any unauthorized modifications to your Buhler product as this could affect function or safety, and could affect the life of the equipment.

Inspect and clean the working area before operating.

Keep hands, feet, clothing, and hair away from moving parts.

Ensure bystanders are clear of the area before operating.

START-UP SAFETY

Do not let inexperienced operators or children run this equipment.

Place all tractor and machine controls in neutral before starting.

Operate only with ROPS and seatbelt equipped tractors.

Do not operate inside a building unless there is adequate ventilation.

Ensure all shields are in place and in good condition before operating.

Stay clear of PTO shaft and machine when engaging PTO.

The auger must be on a level surface and wheels free to move when raising or lowering. Everyone should be kept clear during these operations.

OPERATION SAFETY

Do not permit riders.

Do not wear loose fitting clothing during operation.

Empty the auger before moving to prevent upending.

The Backsaver Auger should be attached to the drawbar of the tractor at all times during operations.

Do not allow anyone other than the operator close to the Auger when in operation.

Never stand under the auger while raising or lowering.

When filling tall bins, tanks, or granaries, it is advisable to anchor the auger to the bin or building to prevent it from being tipped over by the wind or a sudden movement.

Do not operate Intake Auger when it is folded in transport position.

Stay away from overhead obstructions and power lines during operation and transporting. Electrocutation can occur without direct contact.

TRANSPORT SAFETY

Review Transport Safety instructions in tractor manual before moving.

Check with local authorities regarding transport on public roads. Obey all applicable laws and regulations.

Do not tow equipment that does not have brakes at speeds over 32km/h (20 mph).

Do not tow equipment that does not have brakes that, when fully loaded, has a mass (weight) over 1.5 t (3300 lb) and more than 1.5 times the mass (weight) of the towing unit.

Make sure the SMV (Slow Moving Vehicle) emblem and all the lights and reflectors that are required by the local highway and transport authorities are in place, are clean, and can be seen clearly by all overtaking and oncoming traffic.

Always transport the Backsaver Auger in the down position, carrying the weight of the auger on the undercarriage itself, and not the hydraulic cylinder.

Take extreme caution in maneuvering on or around tight corners so as not to catch the end of the auger on trees, buildings, power lines, etc.

The equipment should never be towed without the safety chain securely attached to the auger and the towing vehicle.

When moving the auger on the road, always use a red flag, or if absolutely necessary to move at night, accessory lights for adequate warning to operators of other vehicles.

Always travel at a safe speed.

Inflate transport tires to recommended pressure.

SERVICE AND MAINTENANCE SAFETY

Stop engine, set brake, remove ignition key, and wait for all moving parts to stop before servicing, adjusting, repairing, or unplugging.

Support the equipment with blocks or safety stands before working beneath it.

Follow good shop practices including

- Keep service area clean and dry
- Be sure electrical outlets and tools are properly grounded
- Use adequate light for the job

Use only tools, jacks, and hoists of sufficient capacity for the job.

Replace and secure all shields removed during servicing before operating.

Use heavy leather gloves to handle sharp objects.

Check hydraulics regularly for leaks. Use cardboard to look for leaks, and use hand and eye protection.

Relieve pressure on hydraulic system before repairing or adjusting.

Failure to follow proper procedures when mounting a tire on a wheel or rim can produce an explosion, which may result in serious injury or death.

STORAGE SAFETY

Store the unit in an area away from human activity.

Do not permit children to play on or around the stored machine.

Support the frame on stands and blocks to provide a secure base.

When storing an auger, park it on level ground so that the bottom end will never be over its center of gravity.

Block the wheels of the auger so that the auger will not move and tear the jack from it's mount.

SAFETY SIGNS

The following illustration shows the approximate location and detail of safety signs.

Keep all safety signs clean and legible and replace any that are damaged or missing.

When original parts are replaced, any safety signs affixed to those parts should be replaced as well. Replacement safety signs are available from your local dealer.

INSTALLATION OF SAFETY SIGNS

To install safety signs, ensure the installation area is clean and dry. Decide on the exact position before you remove the backing paper. Remove the smallest portion of the split backing paper and align over the specified area. Carefully press in place. Slowly peel back the remaining paper and smooth the remaining portion in place. Small air pockets can be pierced with a pin and smoothed out.

10" AUGER SAFETY SIGNS (ON INTAKE AUGER)

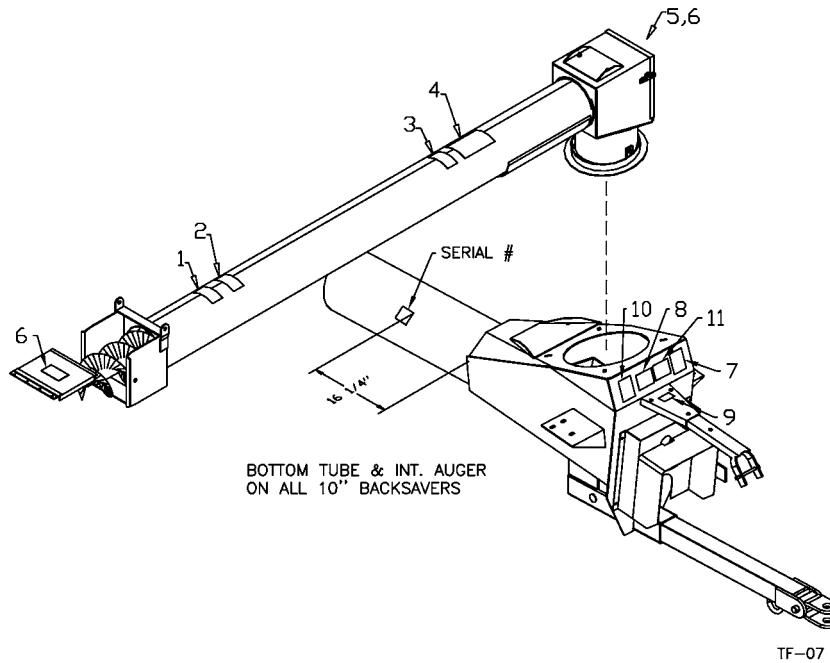

Replace safety signs immediately should they become damaged, torn or illegible. Obtain replacements from your authorized dealer using the part numbers shown



#1

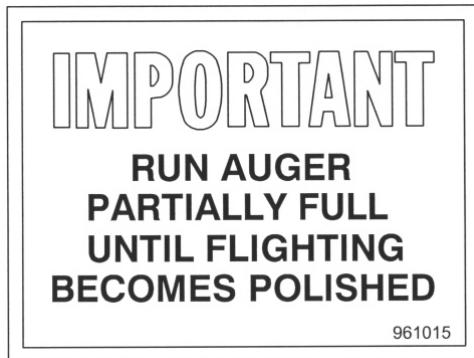

#2

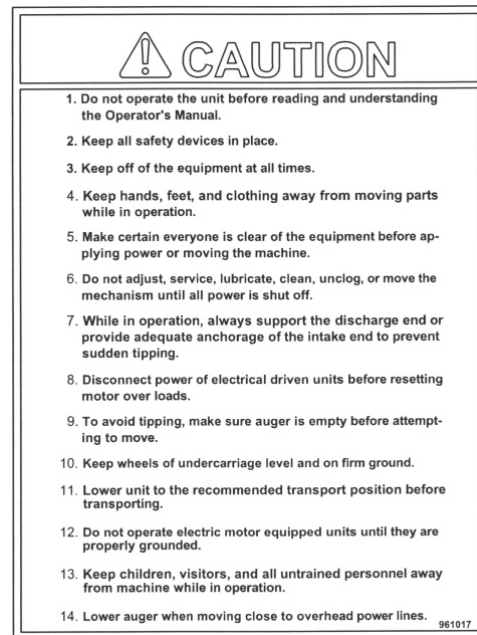

#4

AUGER SAFETY SIGNS (ON INTAKE AUGER) – cont'd.



#3

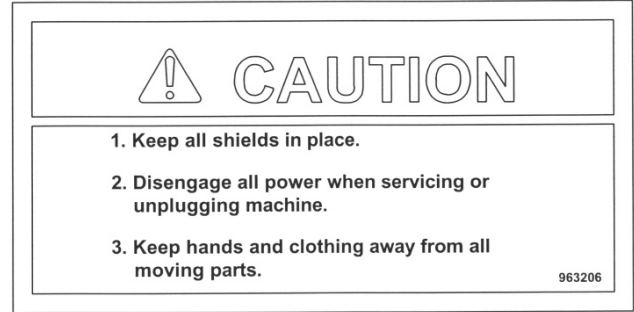

#5

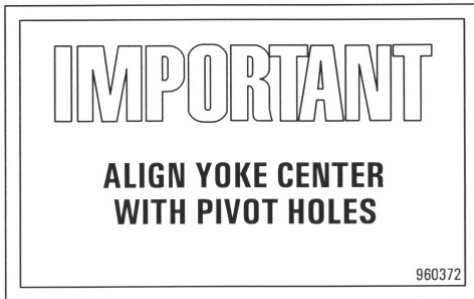

#6

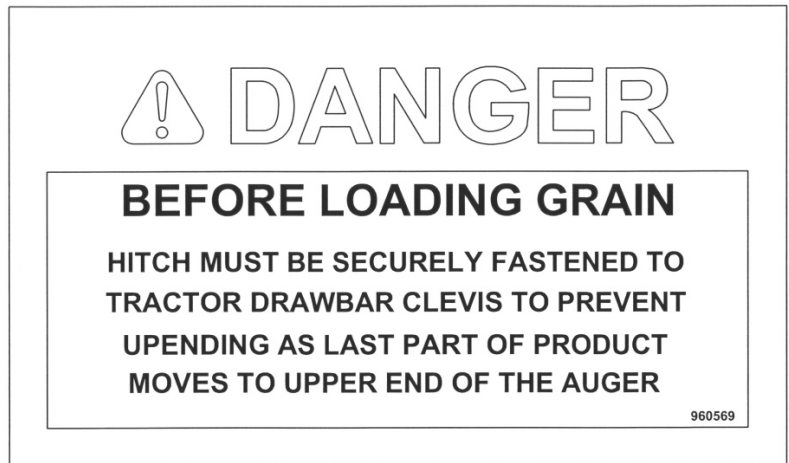

#7

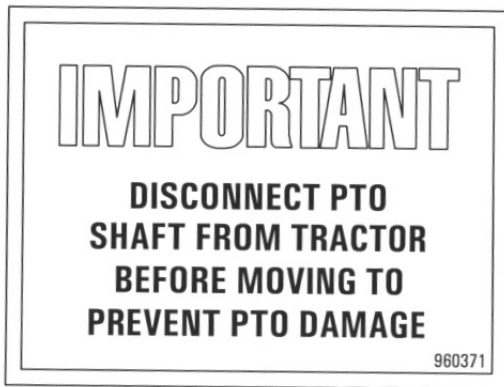

#8

AUGER SAFETY SIGNS (ON INTAKE AUGER) – cont'd.

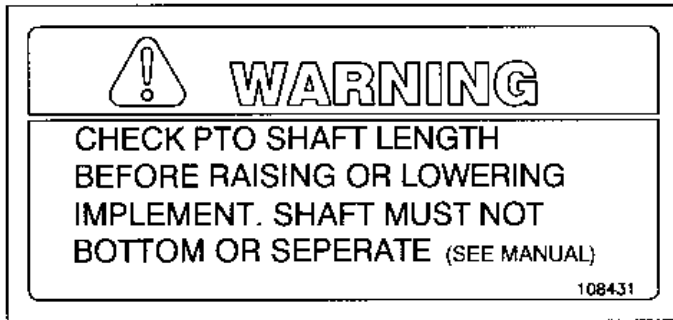

#9

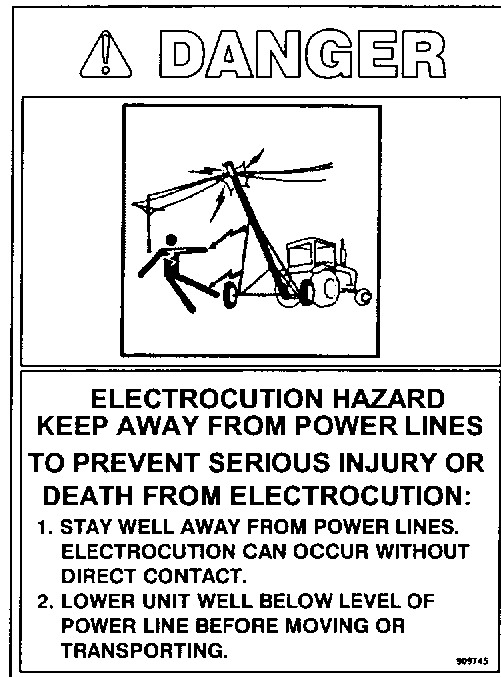

#10

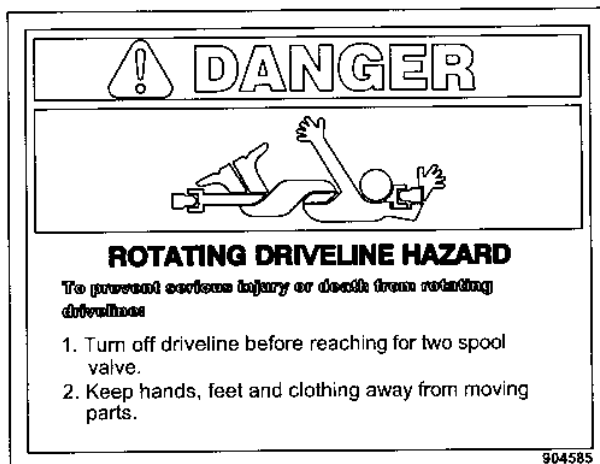

#11

ASSEMBLY INSTRUCTIONS

1. Assemble the top section (#3) to the center section (#2) making sure the flighting is aligned and locked with a 1/2" x 2 3/4" (grade 8) hex bolt and lock nut. Similarly, assemble the bottom section (#1) to the center section. Use 1/2" x 1 1/4" hex bolts, lock washers and hex nuts to fasten the auger rings together. Fasten the input box (#158) to the bottom tube using 1/2" x 1 1/4" hex bolts, lock washers and hex nuts.

⚠ ALERT: There are two holes on the top stub shaft for cotter pin installation on the top flighting, which should allow a wide range of adjustment. If the top flighting is too high, there could be a shortage of room to mount the bottom bearing in the input box.

⚠ ALERT: The chain guard (#171) on the input box must be removed before you begin assembling the auger flightings. No centre section on 50' augers.

2. Bolt bearing flanges (#16) and mount bearing (#17) at the bottom (outside) of the input box using 3/8" x 1" hex bolts, lock washers and hex nuts. Loosen cap at the top end of the auger. After locking the bottom bearing with the collar, tension the flighting by turning the 1 1/4" slotted hex nut at the top of the auger and replace top cap.

Loosen the chain idler assembly on the input box and mount the 15 tooth sprocket (#172) on the flighting bottom stub shaft. Assemble the chain (#173) and then slide the idler assembly into place and tighten. Attach the PTO shaft. The tractor end has a standard 6-spline end with a spring loaded locking collar. The auger end has a clamp-style yoke with a 1/4" keyway. Slide the yoke onto the flighting stub shaft with the 1/4" key supplied. Lock the yoke in place with two 1/2" x 3" bolts and lock nuts fitted through the groove in the flighting stub shaft. After tightening the bolt, insert and tighten the 3/8" socket set screw. Bolt the chain guard (#171) to the bottom of the input box using 5/16" lock washers and hex nuts.

3. The main bridging yoke (#7) is pushed up from underneath the auger and positioned between the two 5/8" square stops welded to the mounting plate. Bolt on using 1/2" x 1 1/2" hex bolts, lock washers, hex nuts and flat washers. Attach tie rod (#8) to top of bridging yoke using 3/8" x 1 1/2" hex bolts, lock washers and hex nuts. The upper bridging yoke (#9) bolts to the welded mount using 1/2" x 1 1/2" hex bolts, lock washers and hex nuts. 70' Augers Only: Bolt the rod (#10) to upper bridging yoke using 3/8" x 1 1/2" hex bolts, lock washers and hex nuts.

ASSEMBLY INSTRUCTIONS – cont'd.

4. Mount both sets of cables (#71) and (#72). The longer cable goes from just above the input box, across both bridging yokes, to the top section. The shorter cable goes from just behind the undercarriage pivot ring, across the main bridging yoke, down to the bottom of the upper bridging yoke. Bolt the cable yokes (#144) to the bottom of each cable using 1/2" x 2" hex bolts, lock washers and hex nuts. Bolt the yokes to the cable brackets welded to the main tubing with the same hardware. Use the bottom hole in the yoke if possible. The other holes can be used if the cable stretches after a few years. Be sure to tighten cables before lifting the auger. The main tubes must be straight or bowed up a few inches before lifting the auger. Any downward bow will result in very loud flighting noise. Tighten cable clamps (#20) on bridging yokes after cables are tight.

 **ALERT:** On the bridging yokes where the cable clamps hold two cables, do not use the cast part of the cable clamp or it will be very difficult to get the nuts on the clamps. Use 3/8" I.D. flat washers on cable clamps.

5. After raising the top end of the auger, clamp on spout (#11) using 3/8" x 2" hex bolts, lock washers and hex nuts. Lift the auger at a point just above the main bridging yoke.
6. Mount the two undercarriage arms (#75) & (#76) to the pivot rings on the bottom section.
7. Mount wheels (#88) on axle using 1/2" wheel bolts and torque bolts to 80 ft/lbs. (108 N.m)
8. Position undercarriage arms on axle (#77) against the welded stop and bolt on using 3/8" x 4 1/2" hex bolts, lock washers and hex nuts. A tie plate (#81) is used to connect the arms. Use 3/8" x 1" hex bolts, lock washers and hex nuts.
9. Bolt undercarriage arches (#78) and (#79) to the undercarriage using 5/8" x 1 3/4" hex bolts, lock washers and hex nuts.

 **ALERT:** The arches are left and right. The bracket for attaching the brace (#80) is turned to the outside. Ends of brace bent at 30° are bolted to the arch. The other end bolts to the undercarriage.

10. Bolt the lift arm cradle (#82) to the angle irons on the undercarriage using 1/2" x 1 1/4" hex bolts, lock washers and hex nuts.
11. Connect the lower lift arm (#74) to the undercarriage arches using 2 13/16" pins (#110) and cotter pins. The top end of the lower lift arm should rest on the cradle bolted to the undercarriage.

ASSEMBLY INSTRUCTIONS – cont'd.

12. Connect the upper lift arm (#73) to the lower lift arm (#74) using the same pins. The other end of the upper lift arm is coupled to the main bridging yoke using an 11 7/8" pin (#109) and cotter pin.
13. Insert connecting link (#106) in lower lift arm and pivot yoke (#105) in upper lift arm using pins in ends as shipped.



ALERT: The welded cross brace on the pivot yoke should be facing the input box end of the auger.

14. Mount base of hydraulic cylinder (#114) to the upper lift arm using cylinder pin (#112) and cotter pin. The ports on the cylinder are turned down for a 50' & 60' auger and up for a 70' auger as per drawing. The rod end of the cylinder, the connecting link and the pivot yoke are all joined with one pin (#111).
15. Connect the 4' hydraulic hose (#133) with attached flow control (#115) and fittings from the base end of the cylinder to the hydraulic line on the main auger. The flow control valve regulates the lowering of the auger to avoid damage which could be caused by lowering the auger too quickly. Arrow should be pointing away from cylinder. Be sure that valve is open approximately 3 1/2 turns before raising to full position or auger will not lower.
10" x 60' only: The hydraulic line on the auger must be coupled at the pipe ring between the bottom and center sections using an 18" hose (#117) as shown on drawing.
16. Using 3/8" x 3/4" sq. hd. set screws (#63) mount the u-joint (#167) on the intake auger gearbox. Position the u-joint by placing a straight edge along the bottom of the pipe ring on the intake auger top box (#161) and measuring exactly 2 1/8" from the top of the straight edge to the center of the u- joint as shown in drawing.

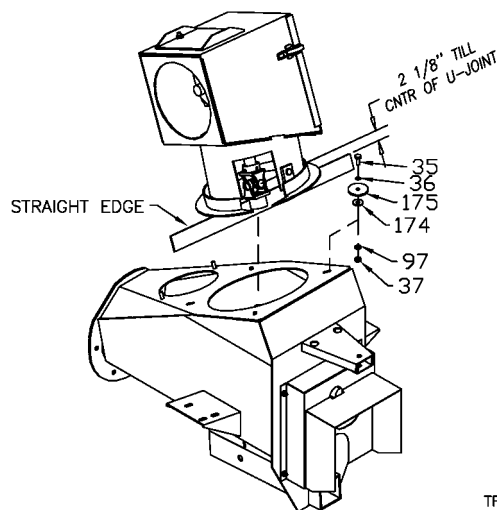

TF-13

ASSEMBLY INSTRUCTIONS – cont'd.

Lift the intake auger assembly onto the input box (#158). The splines on the u-joint just slide onto the splines on the input box gearbox shaft. This will probably require at least two people. Let the ring sit on the input box without forcing it to the exact centre if it is not perfectly positioned.

Remove one of the clean-out covers from the input box and bolt on the ring as shown in the drawing using 3/8" x 1 1/2" hex bolts. Bolt head should be facing up. A 3/8" (10 gauge) flat washer (#97) goes under the input box top cover. The 1 1/4" O.D. flat washers (#174) should be 1/8" to 3/16" from touching the edge of the ring. This is done to prevent side pressure on the u-joint. The 2 1/2" O.D. flat washers (#175) act as a ring holder. Tighten using lock washers and hex nuts. The intake auger should turn freely around the input box after assembly. During actual operation the intake auger may be used on either side of the input box.



ALERT: If the intake auger is removed for repair or replacement, the bolt coupling the flighting to the intake auger gearbox must be replaced when the flighting is replaced. Failure to do so could cause failure of the hopper flighting.

17. Using a 5/16" x 1 3/8" key (#197), join the hopper (#134) and the intake auger (#159) at the universal joint. Join the hopper and intake auger using two 3/4" x 1 5/8" pivot bolts and lock nuts. A flat washer goes on the nut side only. Parts must swivel freely after bolting together. Check that the cross on the u-joint is in line with the two pivot pins. The cover (#198) bolts to the front edge of the hopper using 1/4" x 3/4" hex bolts, lock washers and hex nuts. The cover is held down by the cover rod (#199) which is pushed through the clevises welded to the intake auger and held in place by a spring clip. With the cover (#198) removed, tighten all set screws on the u-joint and be sure that it has grease.



ALERT: Never run the auger without this cover bolted on.

18. **Standard Hopper only:** Bolt the 6" wide rubber edging supplied to the top edge of the hopper on the inside using 1/4" x 1" hex bolts, lock washers and hex nuts. The 1" side strips supplied bolt to the rubber on the inside of the hopper and help keep the rubber from tearing. The ends of the rubber strips are joined using 3" x 3" plates with 1/4" x 1" hex bolts.

Multi-flighting Hopper only: (Page 36)

Bolt the rubber edging (#43) supplied to the top edge of the hopper on the inside using 1/4" x 1" hex bolts, lock washers and hex nuts. One end of the rubber bolts to a welded bracket at the front of the hopper. The long 1" side strips (#19) bolt to the rubber on the inside of the hopper and help keep the rubber from tearing. Two 1" strips (#42) hold the rubber edging of the back end of the hopper. The ends of the two rubber strips are joined by two 3" x 3" connector plates (#41) at the top edge and a 1" x 8" strip (#44) at the bottom edge. All strips use the same hardware.

ASSEMBLY INSTRUCTIONS – cont'd.

19. ALL AUGER SIZES:

The winch must be mounted on the input box on the opposite side to the intake auger. The lift boom (#51) is bolted to a bracket on top of the main tube about 8' from the bottom pipe ring using 1/2" x 1 1/2" bolts, lock washers and hex nuts. Thread the 1/4" cable (#46) around the pulley at the end of the lift boom and then around a cable pulley in the bracket which swivels at the back of the lift boom. From there you go down to the winch. Clamp cable to winch before mounting the winch. There are two flat iron hooks at the front edge of the hopper. Hook the lift cable in the hook furthest away from the auger so the hopper will turn open end toward the auger. The safety chain is attached to the welded loop at the bottom of the intake auger using the hook and quick link supplied. The boom can be used on either side of the auger but the winch must be moved to the opposite side. Fasten winch to the input box on the side opposite the lift boom.

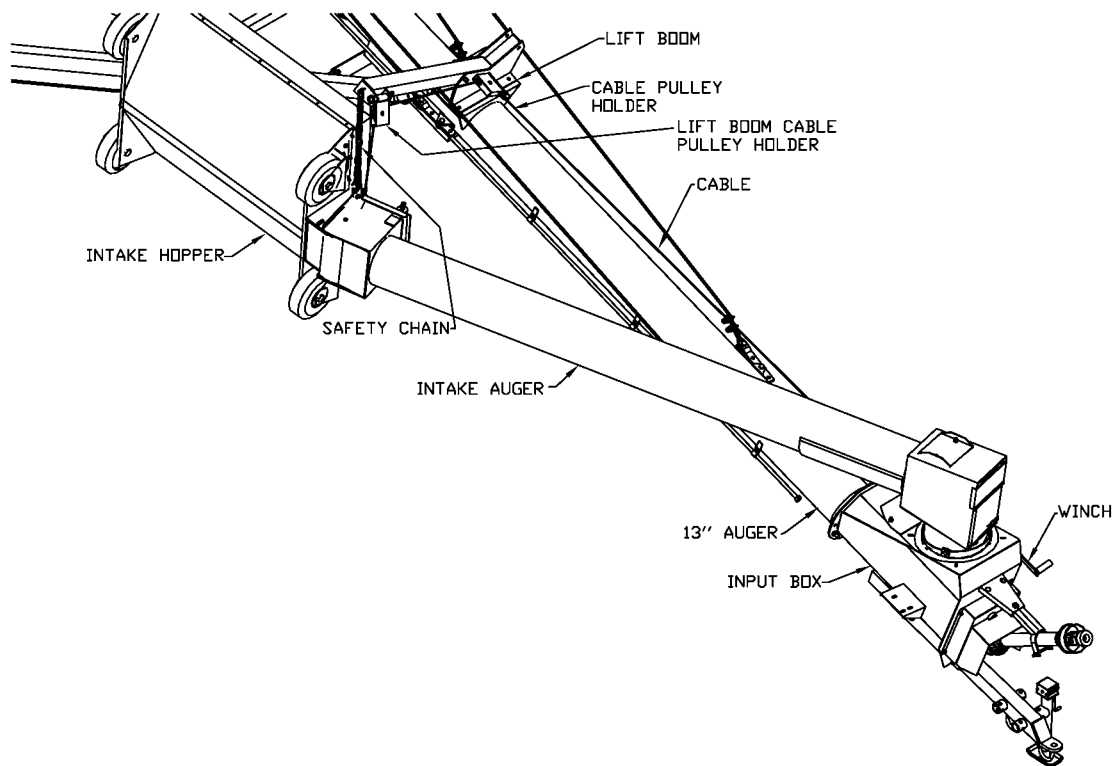

TF-11

⚠️ ALERT: When the intake auger is raised, the lift cable is hooked into the loop at the bottom of the intake auger. The open end of the hook must be turned toward the hopper. The intake auger could detach and fall if the main auger is raised with the hook turned the other way.

ASSEMBLY INSTRUCTIONS – cont'd.

20. Re-check and tighten all bolts.
21. Immediately after setting up the auger, hook it up to a tractor. Raise and lower the auger three or four times to purge all the air out of the hydraulic line to the lift cylinder. This will help to prevent the auger from settling when you have it in working position above a bin.

 **ALERT:** Always check to see that both ends of the PTO shaft are securely attached every time the auger is used. This should always be done with the tractor engine off. When transporting the auger, disconnect the PTO shaft from the tractor. The PTO holder on top of the input box is used to hold the PTO during transport. Do not run the auger with the intake auger in transport position. Doing this will damage the u-joint between the intake auger and the input box.

10" X 10' AUGER EXTENSION – ASSEMBLY INSTRUCTIONS

NOTE: This extension can be used to extend the 70' Auger to 80' only. It is not made to be used on any other size of auger.

1. The 10" Backsaver manual should be used for assembly instructions. The extension (#1) is mounted between the centre and the top sections of the 70' auger. Align all four sections before tightening the pipe ring bolts.
2. The main bridging yoke (#6) is about 12" higher for an 80' vs. a 70' auger. The 80' auger also has two braces (#7) for the main yoke instead of one. The centre section bridging yoke (#4) is about 6" higher than the 70' auger. The 10' extension also has a bridging yoke (#3).
3. Both sets of cables are also longer on a 80' auger than a 70'. The short cables #8 mount at the same place as on the 70' but are a bit longer because of the higher main yoke (#6). The long cables (#9) mount as per the 70' except they are attached to the extra bridging yoke (#3).
4. The rest of the assembly is exactly the same as for a standard 70' auger as described in the 10" Backsaver manual.

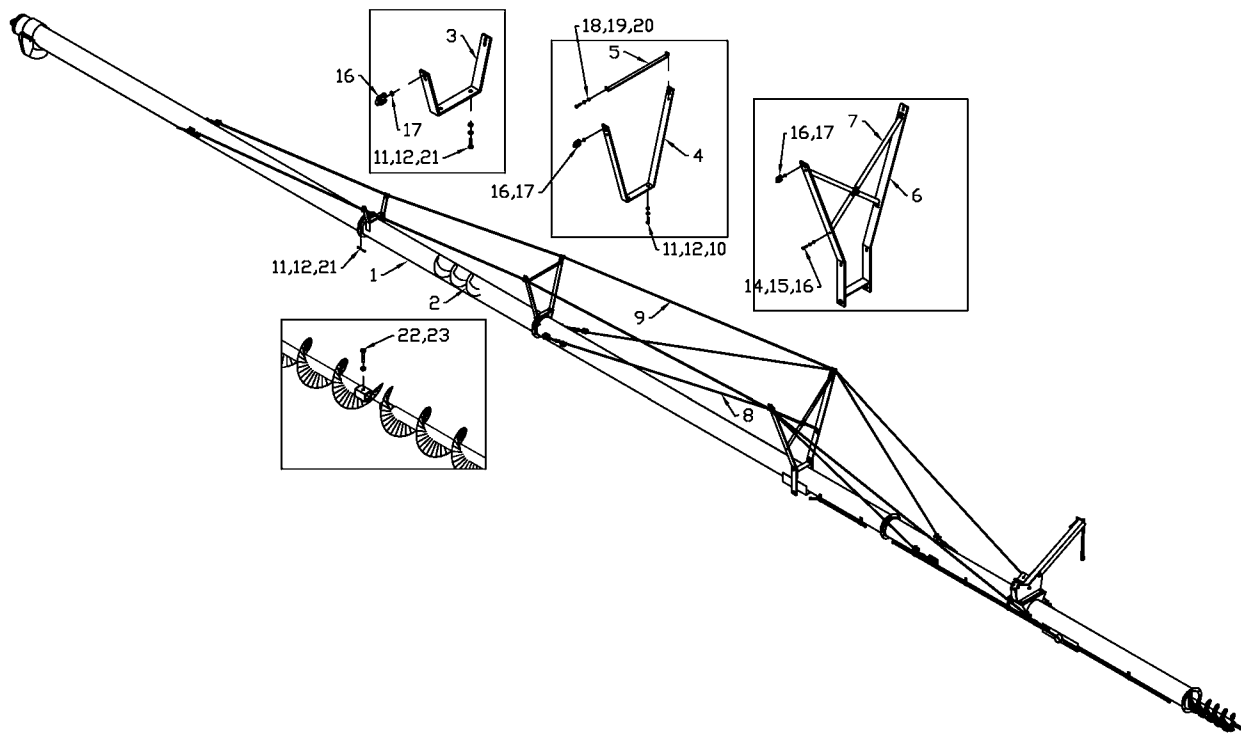

TF-05

OPERATING INSTRUCTIONS

All augers may be elevated up to 45°; however, for the best operating efficiency, 35° should not be exceeded. At angles over 35° the capacity and life of the auger decreases. Use in some types of fertilizer may cause accelerated wear and corrosion as well as added stress on lift components due to additional load. Use in fertilizer can affect warranty.

Run auger partially full until flighting becomes polished.

Never operate an empty auger for over one minute, as the flighting and housing will experience excessive wear.

To position the auger, always tow or move the auger in the down position to a point as close as possible to the bin or barn.

 **ALERT:** Always keep the wheels level. Raise the auger to the desired height and back the auger into position. **Do not** support the auger on the bin. As the auger becomes full it carries a lot of weight and may cause damage to the underside of the auger or to the bin.

 **ALERT:** The auger should be firmly attached to the drawbar of the tractor at all times during operation.

 **ALERT:** Never place blocks under the wheels to increase the elevation of auger.

Be sure the wheels are free to move and no one is standing close to the auger when raising or lowering. Never attempt to raise or lower the auger while it is in operation.

 **ALERT:** Be sure winch brake is working properly before transporting. An arrow on the winch shows the proper direction of rotation. Improper rotation may cause winch failure. Never have less than three wraps of cable on the drum of the winch.

The intake auger swivels freely on the top of the input box. It can be positioned anywhere between the tractor and the side of the auger.

 **CAUTION:** 10" Augers are designed for PTO drive tractors with 540 PTO rpm only. Maximum capacity will be attained while running the main auger between 450 - 500 PTO rpm. (Do not use 1000 PTO rpm speed on these augers)

OPERATING INSTRUCTIONS – cont'd.

⚠ ALERT: Always maintain at least a 4" over lap on the PTO guards. Be sure they turn freely and make certain everyone stands clear of tractor, PTO shaft, and auger before engaging PTO. Be sure ends are securely connected to the auger and tractor. An optional shaft is offered for extreme use.

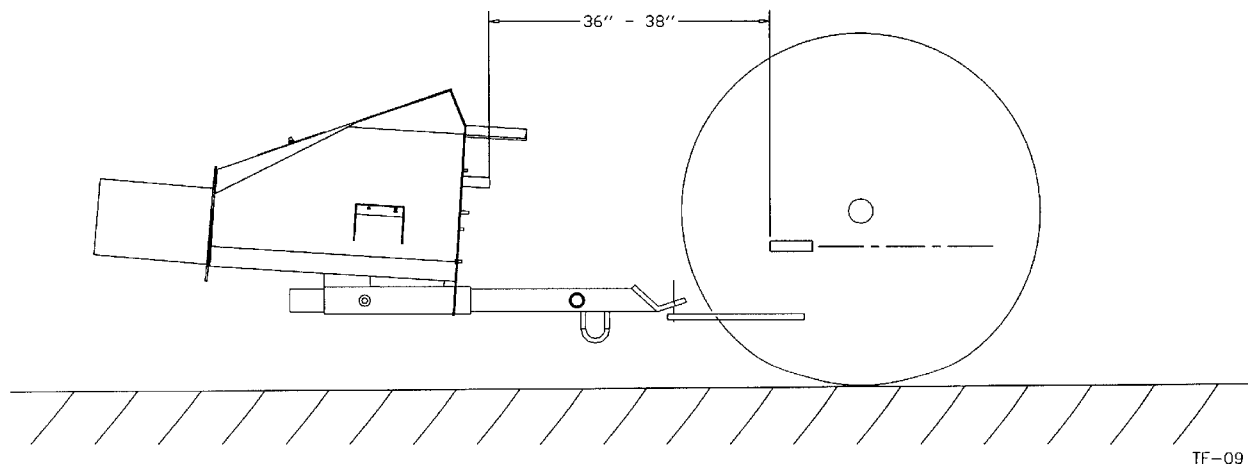

The distance between the tractor and the auger stubs should be between 36" and 38" with the tractor and auger on level ground and the auger in full down position. This distance is obtained by either adjusting the tractor hitch, the auger hitch or both.

Before engaging PTO, start tractor and idle engine. Engage PTO slowly and bring up to recommended speed of 500 PTO rpm for 10" augers.

Before stopping auger (except in an emergency) let all grain empty out of the auger, idle engine then disengage PTO. Shut off tractor.

⚠ ALERT: Do not use the reverse kit to attempt to unplug the auger. The reverse kit is designed to be used for CLEAN-OUT ONLY!

⚠ ALERT: When auger is left in raised position over night, close the ball valve on the hydraulic line to the cylinder. This will prevent the auger from lowering, due to hydraulic leakage, and avoid possible damage.

One-way flow control valve (#115) can be adjusted by loosening the hex nut on the side, and turning on the screw with the machined end. Turning the screw in decreases the speed the auger lowers, while turning it out increases the speed. The approximate initial setting should be three turns out from the tight position. When set, re-tighten hex nut to set position.

OPERATING INSTRUCTIONS – cont'd.

⚠ ALERT: Be sure that the valve is somewhat open before raising the first time or auger will not lower.

Be sure there is always some tension on the flighting by adjusting the end thrust bearing, at the upper end of the auger.

⚠ ALERT: Always lower auger before transport and allow the weight of the auger to rest on the undercarriage and not the hydraulic cylinder.

Be certain to turn jack sideways when towing auger.

Disconnect the PTO shaft from the tractor and pin it in the PTO holder (#124 & #170) when towing or manoeuvring the auger. This will prevent possible damage to the shaft during cornering.

⚠ ALERT: If the PTO shaft angle exceeds 50° during a tight turn, the constant velocity joints will be fractured and will likely fail shortly thereafter during operation.

PTO shear bolts (2 required) - 5/16" x 1" hex bolt (grade 5)

⚠ ALERT: When towing the auger, never exceed 32 km/h (20 mph).

Always use a flag, or at night, a signal light when towing an auger on a road. Check your local regulations for further safety devices in this regard.

10" BACKSAVER INTAKE AUGER PIVOT HOPPER

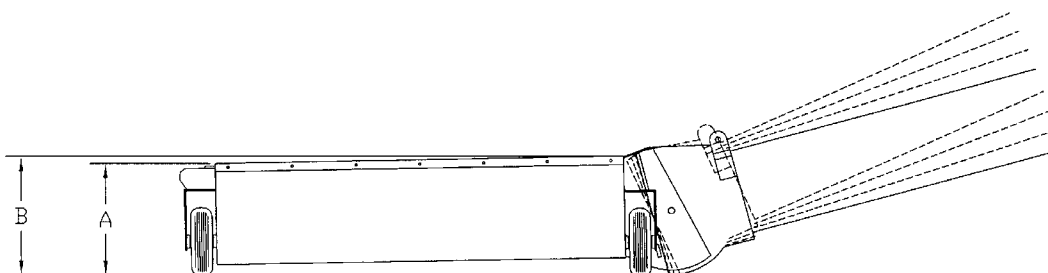

DIMENSION	10" AUGER	13" AUGER
A	13"	14 1/2"
B	14"	15 1/2"

TF-08

⚠ ALERT: All heights shown are for the welded hopper only. These heights remain the same at all auger working angles because of the pivot joint between the hopper and the intake auger.

THEORY OF OPERATION

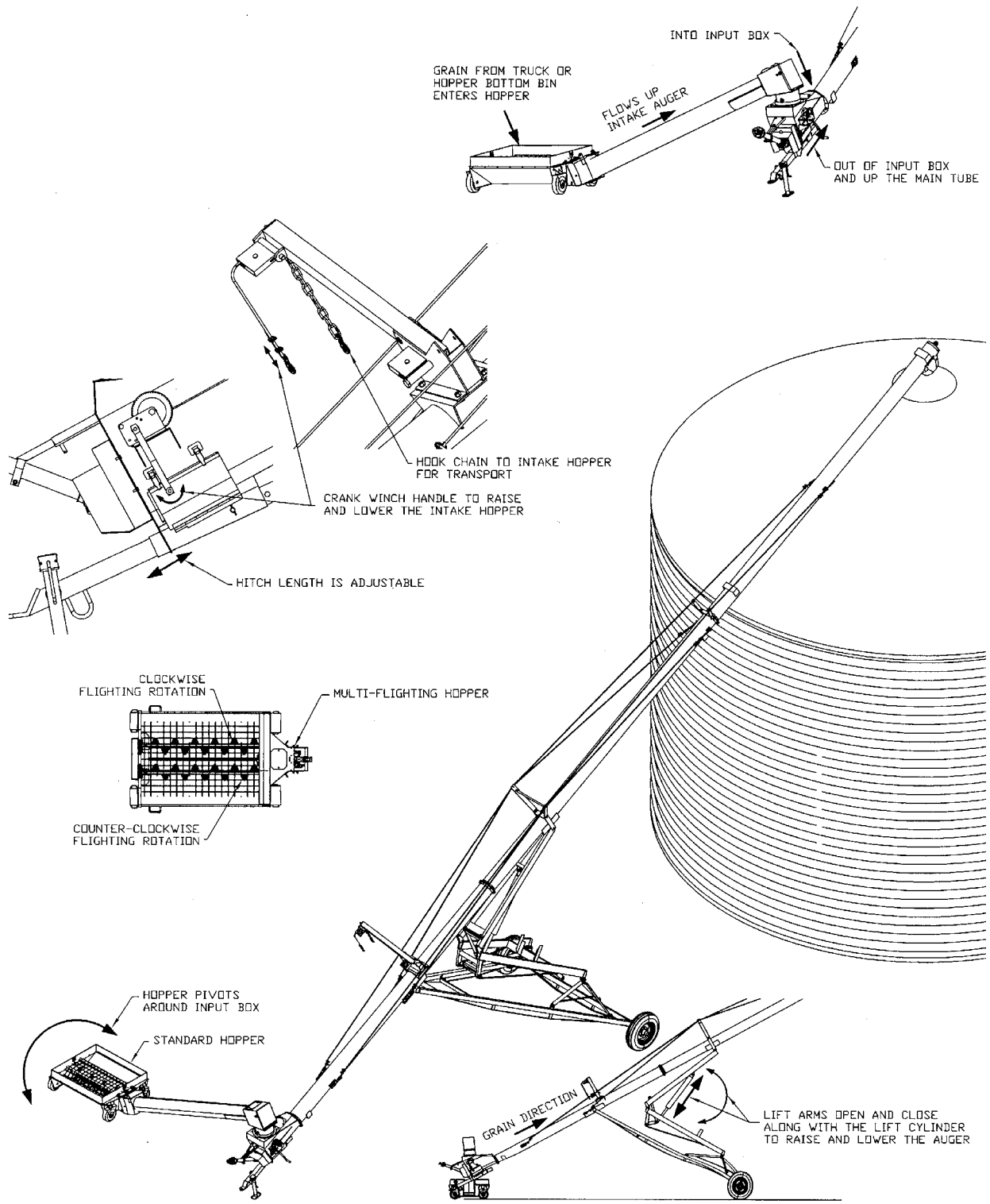

ALL FLIGHTING ROTATES IN THE CLOCKWISE DIRECTION UNLESS OTHERWISE SHOWN

MAINTENANCE & LUBRICATION

Check condition of winch cable occasionally. Be sure it is lubricated.

Check to see that there is no downward bow in the main tubes at the start of every augering season. Re-tension cables if required as per step number four in the assembly instructions. This should also be checked immediately after hauling the auger for a long distance.

Use a high temperature grease for all lubrication.

Lubricate the PTO shaft as per instruction sheet.

Check grease on end thrust bearing to be sure it is running smoothly and freely. Remove cap and grease at the start of every season.

Check hydraulic lines frequently for leaks or damage

Grease u-joint in intake auger after 8 hours of use.

Grease the u-joint connecting the two gearboxes about every 8 hours. Do regular checks on the oil level in the gearboxes. Fill if necessary to the height of the side plug using SAE 90 oil. Because the gearbox runs in the grain, it is difficult to see any oil leaks so regular checks should be done.

 **ALERT:** When replacing bearings or tightening a loose bearing collar, always tighten collar in the direction of shaft rotation using a centre punch or a similar tool.

Recommended tire pressure is 35 psi. (240 kPa)

STORAGE

The auger should be stored in a dry place if possible. If stored outside, lower auger to its lowest position and block up the wheels so auger will not move.

Clean auger thoroughly as dirt draws moisture and causes metal to rust. If the auger has been used to move fertilizer, clean thoroughly and apply oil or grease on entire flighting and inside the housing to stop and prevent further corrosion.

At this time check all moving parts for wear and order replacement parts from your nearest dealer.

When taking the auger out of storage, clean it thoroughly and check for obstructions at the inlet and outlet ends.

Check all bolts and set screws.

RECOMMENDED CUSTOMER GREASING PROCEDURE FOR 50" C.V. PTO

A general purpose grease may be used, however, a grease containing 3% molybdenum disulfide will allow the lube intervals to be extended to twice as long as that listed. The first lube interval should be 16-24 hours of operation after initial start-up then follow the schedule below. Constant angle applications must have a lube interval of 4 hours.

LUBE RECOMMENDATIONS

INTERVAL	LOCATION	AMOUNT
8 hrs.	Cross & Bearings	1 pump
8 hrs.	Telescoping Members	4 – 8 pumps (until grease comes out of end)
8 hrs.	CV Ball & Socket	1 – 2 pumps

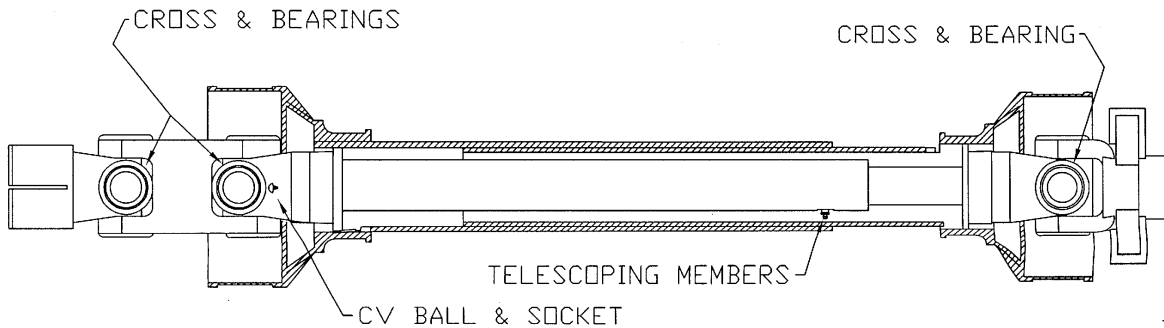

Grease containing various percentages of molybdenum disulfide are available as extreme pressure greases. Please note that all E.P. greases do not contain moly. So some investigation may be necessary. The following greases all contain 3% moly.: Mobile Oil Company "Mobile Grease CMP"; Shell Oil Company "Retinax AM"; and Texaco "Molytex EP #0 and #2".



TF-10

Regularly check the tightness of all cable clamps to avoid slipping.

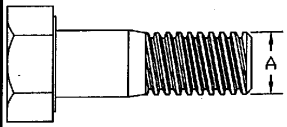
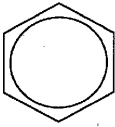
BOLT TORQUE

Bolt Torque						
						
Bolt Diameter	SAE2		SAE5		SAE8	
"A"	N.m	lb-ft	N.m	lb-ft	N.m	lb-ft
1/4"	8	6	12	9	17	12
5/16"	13	10	25	19	36	27
3/8"	27	20	45	33	63	45
7/16"	41	30	72	53	100	75
1/2"	61	45	110	80	155	115
9/16"	95	70	155	115	220	165
5/8"	128	95	215	160	305	220
3/4"	225	165	390	290	540	400
7/8"	230	170	570	420	880	650
1"	345	225	850	630	1320	970

10" BACKSAVER AUGER

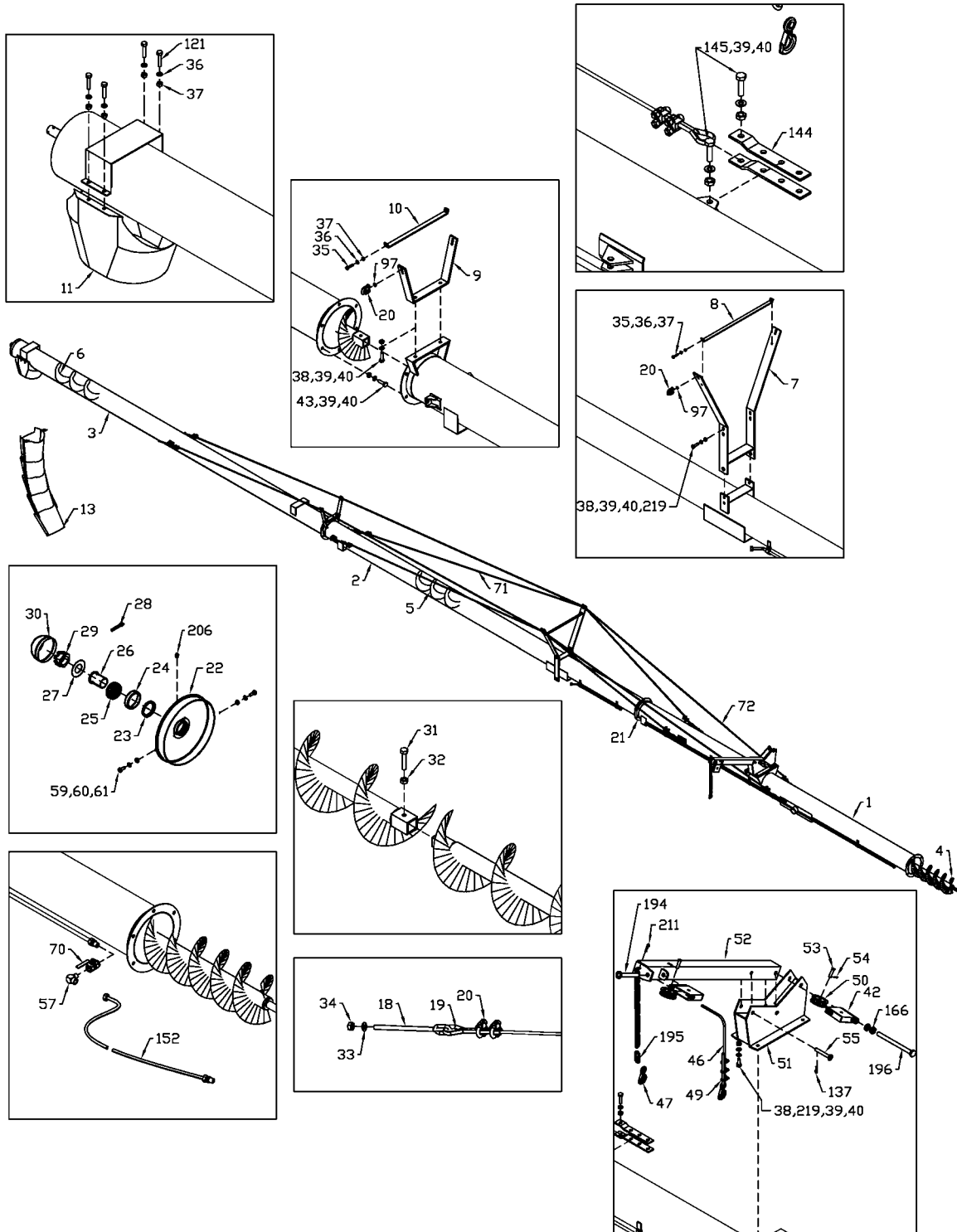

TF-01

10" BACKSAVER AUGER

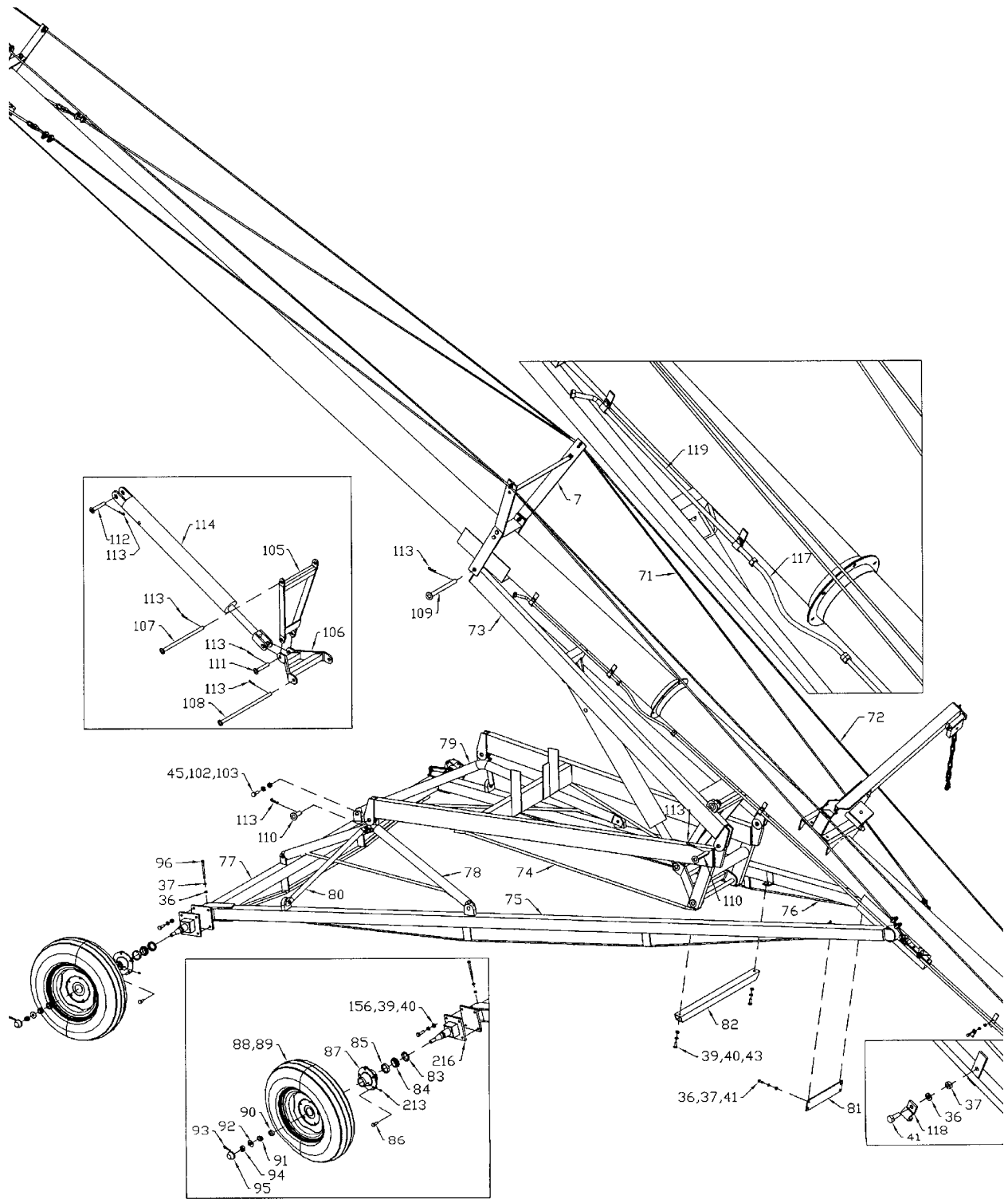

TF-02

10" AUGER – TOP FEED HYDRAULIC SYSTEMS

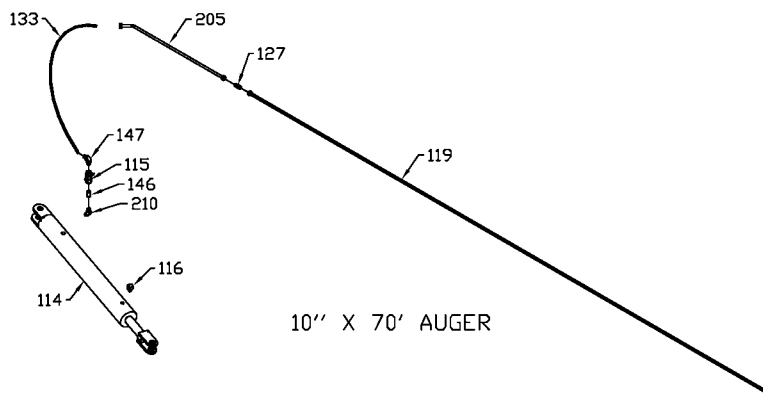
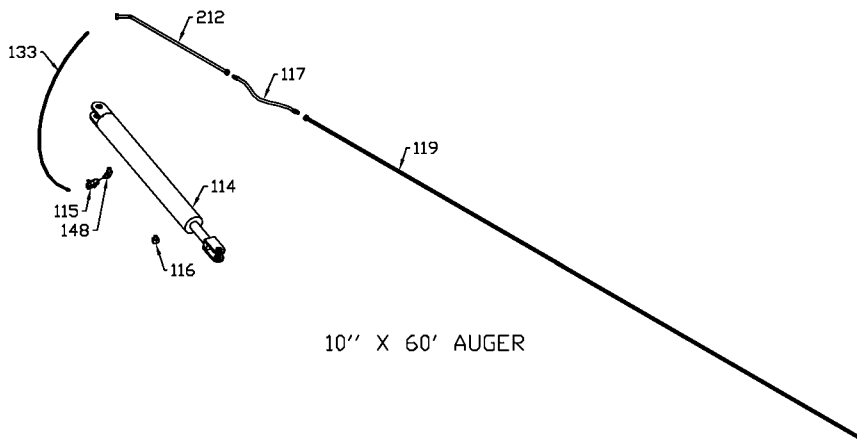
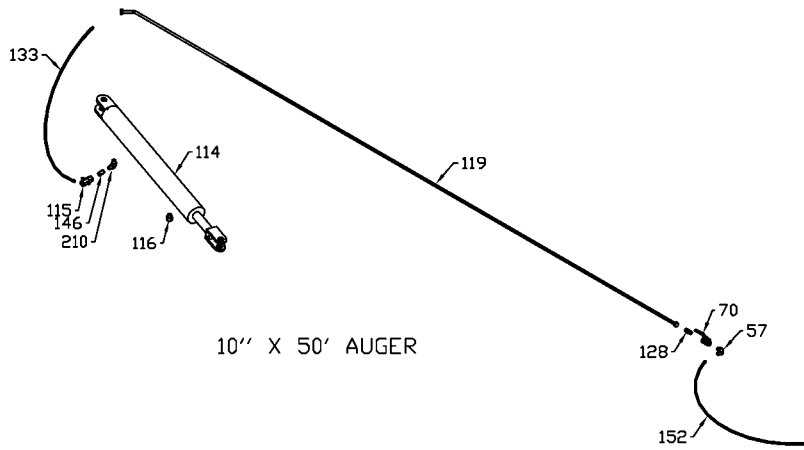

WHEN ORDERING PARTS

Always give your dealer the Model, Color and Serial Number of your machine to assist him in ordering and obtaining the correct parts. Use the exploded view and tabular listing of the area of interest to exactly identify the required part.

10" BACKSAVER AUGER PARTS LIST

Item #	Part #	Description
1	905644	27'4" Bottom Tube, 50'
	905645	17'4" Bottom Tube, 60'
	905646	27'4" Bottom Tube, 70'
2	960004	20' Center Tube, 60'
	960005	20' Center Tube, 70'
3	960006	20' Top Tube, 50'
	960007	20' Top Tube, 60'
	960008	20' Top Tube, 70'
4	960538	30' Bottom Flighting, 50' & 70'
	960543	20' Bottom Flighting, 60'
5	960011	20' Center Flighting, 60' & 70'
6	960012	20' Top Flighting, All Sizes
7	960014	Main Bridging Yoke, 50' & 60'
	960015	Main Bridging Yoke, 70'
8	960016	Main Bridging Tie Rod, 50' & 60'
	960017	Main Bridging Tie Rod, 70'
9	960018	Upper Bridging Yoke, 50' & 60'
	960019	Upper Bridging Yoke, 70'
10	960020	Upper Bridging Tie Rod, 70'
11	F9047	Discharge Spout
12	12780	#7 Hair Pin Clip
13	F3004	Discharge Flexible Spout (Option)
14	F9042	PTO Shaft with CV Joint
	936166	Tractor Half PTO, 10" (6 Splined End)
	936317	Auger Half PTO, 10"
	F9043	PTO Shaft, CV-10" (2-6 Splined Ends)(Rev Model)
	936166	Tractor Half PTO, 10" (6 Splined End)
	908718	Auger Half PTO, 10" (6 Splined End)(Rev Model)
	15	960172
16	961675	Flange Bearing (72MS) Pair PI
17	961676	1 1/4" Bearing with Collar
18	960031	1/2" x 7 7/8" Cable Tightener, 50' & 60'
	960032	3/4" x 7 7/8" Cable Tightener, 70'
19	964267	3/8" Cable Thimble, 50' & 60'
	964587	1/2" Cable Thimble, 70'

20	964264	3/8" Cable Clamp, 50' & 60' - Upper Bridging
	964565	1/2" Cable Clamp, 70' & 50'/60' Main Bridging
21	960033	10" Connection Ring
22	960034	Top End Plate
23	960125	Oil Seal (CR14939)
24	967709	Inner Bearing Cup (LM29710)
25	967708	Inner Bearing Cone (LM29749)
26	960035	Sleeve
27	9812442	Washer
28	812435	Cotter Pin - 1/4" x 1 3/4"
29	960037	1 1/4" Slotted Hex Nut (Fine Thread)
30	967209	Dust Cap (DC 15)
31	9812368	1/2" x 2 3/4" (Grade 8) Hex Bolt
32	812364	1/2" Lock Nut
33	81638	1/2" Flat Washer, 50' & 60'
	84050	3/4" SAE Flat Washer, 70'
34	81636	1/2" Hex Nut, 50' & 60'
	81700	3/4" Hex Nut, 70'
35	811792	3/8" x 1 1/2" Hex Bolt
36	81593	3/8" Lock Washer
37	81592	3/8" Hex Nut
38	84277	1/2" x 1 1/2" Hex Bolt
39	81637	1/2" Lock Washer
40	81636	1/2" Hex Nut
41	86170	3/8" x 1" Hex Bolt
42	905602	Pulley Holder
43	81620	1/2" x 1 1/4" Hex Bolt
44	81678	5/8" Flat Washer
45	81676	5/8" Hex Nut
46	960040	Intake Lift Cable, 1/4" x 28'-3" (Assembled)
	960206	1/4" x 28'-3" Cable Only
47	960041	Lift Cable Hook
48	960749	1 1/4" Bearing with Collar * This Bearing has a Triple Lip Seal
49	961658	1/4" Cable Clamp
50	961846	Cable Pulley, 1/2" Bore
51	905601	Lift Boom
52	905604	Lift Boom Arm
53	960913	1/2" x 1 13/16" Clevis Pin
54	9812430	1/8" x 1" Cotter Pin
55	905568	Pin 5/8" x 4 1/4"
56	960048	2 1/2" x 8" Wheels
	960400	Wheel Bearing Only
57	960585	1/2" x 90° Street Elbow (Steel)
58	961627	1" Bearing

59	81549	5/16" x 3/4" Hex Bolt
60	81569	5/16" Lock Washer
61	81568	5/16" Hex Nut
63	9812378	3/8" x 3/4" Square Head Set Screw (SER)
65	812482	5/8" Lock Nut
67	81545	1/4" Lock Washer
68	81544	1/4" Hex Nut
69	81525	1/4" x 3/4" Hex Bolt
70	960057	1/2" Ball Valve
71	960219	3/8" x 21'-3" Cable (50' Assembled)
	960220	3/8" x 22'-11" Cable Only
	960221	3/8" x 26'-8" Cable (60' Assembled)
	960222	3/8" x 28'-4" Cable Only
	960223	1/2" x 30'-11" Cable (70' Assembled)
	960224	1/2" x 32'-7" Cable Only
72	960225	3/8" x 36' Cable (50' Assembled)
	960226	3/8" x 37'-8" Cable Only
	960227	3/8" x 43'-2" Cable (60' Assembled)
	960228	3/8" x 44'-10" Cable Only
	960229	1/2" x 54'-7" Cable (70' Assembled)
73	960230	1/2" x 56'-3" Cable Only
	F9021	82 1/4" Upper Lift Arm, 50'
	F9022	95" Upper Lift Arm, 60'
74	F9023	108" Upper Lift Arm, 70'
	F9024	82 1/4" Lower Lift Arm, 50'
	F9025	95" Lower Lift Arm, 60'
75	F9026	108" Lower Lift Arm, 70'
	F9253	153" Right Hand Und. Arm 50'
	F9251	184" Right Hand Und. Arm 60'
76	F9249	202" Right Hand Und. Arm 70'
	F9252	153" Left Hand Undercarriage Arm 50'
	F9250	184" Left Hand Undercarriage Arm 60'
77	F9248	202" Left Hand Undercarriage Arm 70'
	F0171	96" Axle 50'
	F0172	108" Axle 60'
78	F0173	132" Axle 70'
	960079	54 1/2" Right Hand Undercarriage Arch, 50'
	960080	80" Right Hand Undercarriage Arch, 60'
79	960081	85" Right Hand Undercarriage Arch, 70'
	960082	54 1/2" Left Hand Undercarriage Arch, 50'
	960083	80" Left Hand Undercarriage Arch, 60'
80	960084	85" Left Hand Undercarriage Arch, 70'
	960085	19 1/2" Arch Brace, 50'
	960086	30" Arch Brace, 60'
	960087	35" Arch Brace, 70'

81	960088	16" Tie Plate, 50' & 60'
	960089	18" Tie Plate, 70'
82	904980	33 1/4" Lift Arm Cradle, 50'
	904981	36' Lift Arm Cradle, 60'
	904982	41' Lift Arm Cradle, 70'
83	968430	Oil Seal (SE 14)
84	967208	Inner Bearing Cone (LM48548)
85	968412	Inner Bearing Cup (LM48510)
86	968404	1/2" Wheel Bolt
87	968403	5 Bolt Hub with Bearing Cups
	968431	5 Bolt Hub CTD H516 Complete Assembly
88	F0110	15" x 5" x 5 Bolt Wheel
89	959203	6.70 x 15 x 4 Ply Tire
	959202	7.60 x 15 x 4 Ply Tire
90	968405	Outer Bearing Cup (LM11910)
91	968406	Outer Bearing Cone (LM11949)
92	9812416	Washer (3/4" S.A.E.)
93	9812486	1/8" x 1 1/2" Cotter Pin
94	81834	3/4" Slotted Hex Nut
95	968409	Dust Cap (DC 12)
96	81588	3/8" x 4 1/2" Hex Bolt
97	84000	3/8" Flat Washer
98	81598	7/16" x 1 1/4" Hex Bolt
99	81615	7/16" Lock Washer
100	81614	7/16" Hex Nut
101	811796	1/2" x 2 1/2" Hex Bolt
102	84270	5/8" x 1 3/4" Hex Bolt
103	81677	5/8" Lock Washer
104	960150	Winch (K1050)
105	960093	Pivot Yoke, 50'
	960094	Pivot Yoke, 60'
	960095	Pivot Yoke, 70'
106	960096	Connecting Link, 50'
	960097	Connecting Link, 60'
	960098	Connecting Link, 70'
107	960099	1" x 16 1/8" Yoke Pin, 50'
	960100	1" x 17 7/8" Yoke Pin, 60'
	960101	1 1/4" x 22" Yoke Pin, 70'
108	960102	1" x 20" Connecting Link Pin, 50'
	960103	1" x 22" Connecting Link Pin, 60'
	960104	1 1/4" x 26" Connecting Link Pin, 70'
109	960105	1" x 11 7/8" Lift Arm Pivot Pin, 50' & 60'
	960106	1 1/4" x 12 1/4" Lift Arm Pivot Pin, 70'
110	960107	1" x 2 13/16" Lift Arm Clevis Pin, 50' & 60'
	960108	1 1/4" x 2 13/16" Lift Arm Clevis Pin, 70'

111	960109	1" x 5 1/2" Cylinder Swivel Pin, 50' & 60'
	960110	1 1/4" x 5 1/2" Cylinder Swivel Pin, 70'
112	960111	1" x 6 3/8" Cylinder Base Pin, 50'
	960112	1" x 6 7/8" Cylinder Base Pin, 60'
	960113	1 1/4" x 7 3/4" Cylinder Base Pin, 70'
113	9812433	3/16" x 1 1/2" Cotter Pin, 50' & 60'
	81210	1/4" x 2" Cotter Pin, 70'
114	F9183	3 1/2" x 30" Hydraulic Cylinder, 50'
	F9184	4" x 36" Hydraulic Cylinder, 60'
	F9185	4" x 40" Hydraulic Cylinder, 70'
115	960118	1/2" One Way Flow Control Valve
116	967908	Vented Plug (3/4 - 16ORB)
117	960162	1/2" x 18" Hydraulic Hose (Both Ends Solid - Both End JIC) - 60'
118	960140	Hydraulic Clamp
119	960469	5/8" O.D. x 16'-2" Hydraulic Line, 50'
	960467	5/8" O.D. x 15'-10" Hydraulic Line, 60'
	960468	5/8" O.D. x 13'-4" Hydraulic Line, 70'
120	81634	1/2" x 5 1/2" Hex Bolt
121	967291	3/8" x 2" Hex Bolt Full Thread
122	812363	3/8" Lock Nut
123	960327	Jack
124	961539	3/8" x 4 1/2" PTO Holder Pin
127	812711	JIC Male to Male Coupler
128	960152	JIC to 1/2" NPT Male to Male Adapter
129	909926	Hopper Rubber Edging (3/16"x6"x102" - 2/Hopper)
130	903483	Rubber Connector Plate (3" x 3")
131	960660	Side Rubber Reinforcement (1" x 57 1/4")
132	960661	End Rubber Reinforcement (1" x 13 1/2")
133	960160	1/2" x 4' Hydraulic Hose (One End 1/2" NPT)(One End JIC)
134	909927	Intake Hopper
135	909923	Intake Hopper Flighting
136	960547	Universal Joint (1140 Series)
	936079	Repair Kit Only For U-Joint
137	961012	#16 Hair Pin Clip
138	900930	1/4" x 1 1/2" Key (Alloy)
139	988999	3/8" x 3/8" Socket Set Screw
141	81527	1/4" x 1" Hex Bolt
144	960244	Cable Yoke
145	811791	1/2" x 2" Hex Bolt
146	811469	1/2" Nipple (Steel)
147	960330	1/2" x 45° Street Elbow (Steel)
148	906541	Elbow 90° 3/4" MORB x 1/2" MNPT

149	909955	3" Square x 48" Hitch Tube
	909957	3" Square x 45" Hitch (Option)
	960927	Clevis (Option - Required with 45" Hitch)
150	811790	3/4" x 4 1/2" Hex Bolt
151	961010	1/2" x 2 1/8" Clevis Pin
152	960466	1/2" x 112" Hydraulic Hose (B.E. Solid & 1/2" NPT)
156	87553	1/2" x 1 3/4" Hex Bolt
158	909631	Input Box
	905620	Clean-Out Lid
159	960754	Intake Auger Tube
160	960941	Intake Auger Flighting
	903214	Splined Coupler Only
161	905663	Intake Auger Top Box
162	960481	Ring (10 1/16" I.D.)
163	960952	Intake Auger Gearbox
164	960483	Intake Auger & Input Box Clean-Out Lid
165	905665	Door 14 1/8" x 15 1/4"
166	86111	3/4" Jam Nut (pl)
167	960393	U-Joint
	906546	Extended Life Repair Kit (Standard)
	936224	Repair Kit (Optional)
168	960953	Input Box Gearbox
170	960459	PTO Holder - 14"
	960181	PTO Holder -19" (Reverse Model)
171	960926	Chain Cover
172	961684	15T Sprocket. #60, 1 1/4" Bore
173	960493	#60 Chain x 38 Links
174	960494	1 1/4" OD 13/32" ID Washer
175	960495	2 1/2" OD 13/32" ID Washer
177	967163	5/16" x 3/4" Flat Head Socket Cap Screw
178	967906	3/8" x 2 3/4" Hex Bolt (Gr 8)
180	960531	Idler Arm
	960183	Idler Assembly (Arm, Sprocket Bearings, Shaft, Etc.)
	906579	Idler Assembly (with Reverse Shaft)
181	960532	15T Sprocket, #60, 1" Bore
182	963009	1" Bearing Flange Set
183	960533	1" x 4 1/2" Idler Shaft
	960182	Reverse Idler Shaft 8 3/4" x 6 Spline
184	960177	1/4" x 1 1/4" Key (Alloy)
186	960164	Bearing Hanger
187	960658	1 1/4" Wooden Bearing & Flange Set
	960659	1 1/4" Wooden Bearing Only
188	86171	3/8" x 1 1/4" Hex Bolt
189	81600	7/16" x 1 3/4" Hex Bolt
190	981616	7/16" Flat Washer

192	81672	5/8" x 4 1/2" Hex Bolt
194	905570	3/4" x 6 3/8" Pin
195	960167	5/16" Quick Link
196	811803	3/4" x 10" Hex Bolt
197	960180	5/16" x 1 3/8" Key (4140 Alloy)
198	960348	Hopper Lid
199	960349	Hopper Lid Rod (5/8" x 15")
200	967437	3/4" x 1 5/8" Bolt
202	812365	3/4" Lock Nut
203	84050	3/4" Flat Washer Sae
204	967183	5/16" x 1" Flat Head Bolt
205	960144	5/8" O.D. x 11' Hydraulic Line - 70'
206	967164	Drive-In Grease Zerk
207	960929	Deflector Extension
208	903925	Wheel Bracket (Right Hand)
209	903924	Wheel Bracket (Left Hand)
210	812693	Elbow 45° 3/4" MORB x 1/2" SWFNPT
211	9812433	3/16" x 1 1/2" Cotter Pin
212	960143	5/8" O.D. x 36" Hydraulic Line - 60'
213	967900	1/4" Grease Fitting
215	81700	3/4" Hex Nut
216	906437	Stub Axle
218	81546	1/4" Flat Washer
219	81638	1/2" Flat Washer
220	909277	Manual Holder
224	904123	Adaptor Assembly, Pump 1 1/4" (6 Spline)
225	81213	Setscrew Squareheadcup 3/8" x 1"
226	986045	3/8" Nut Hex Jam Gr. 2
227	84346	3/4" x 2 1/2" Hex Bolt
228	F0420	1/4" Safety Chain

10" MECHANICAL DRIVE AUGER REVERSE KIT

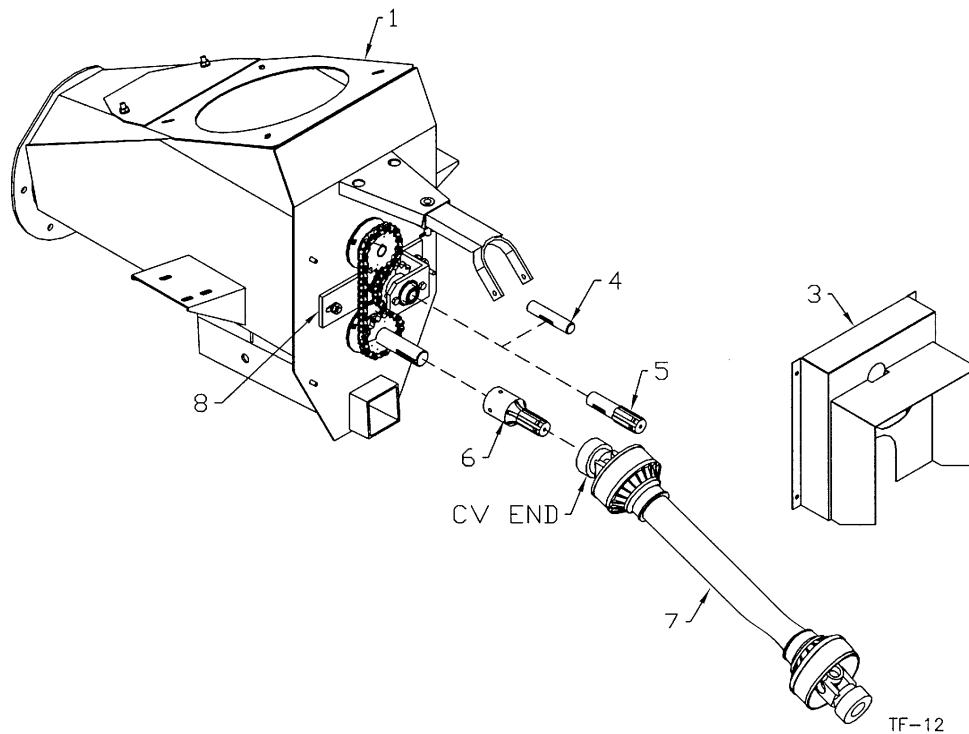

10" BACKSAVER AUGER REVERSE KIT PARTS LIST

Item #	Part #	Description
1	909631	Input Box
2	960181	PTO Holder (19" Long)
3	960926	Chain Cover
4	960533	1" x 4 1/2" Idler Shaft
5	960182	6-Splined Shaft (8 3/4" Long)
6	904123	1 1/4" I.D. Pump Adapter
7	936218	6-Spline End Yoke
	F9043	PTO Shaft, CV-10" (2-6 Splined Ends)(Rev Model)
	936166	Tractor Half PTO, 10" (6 Splined End)
	908718	Auger Half PTO, 10" (6 Splined End)(Rev Model)
8	906579	* Idler Assembly with Reverse (Arm, Sprocket, Bearings, Shaft, etc.)

- The Reverse Kit cannot be used without the idler assembly. The idler assembly is standard on all '92 and up Mechanical Drive Augers.

10" MULTI-FLIGHTING HOPPER

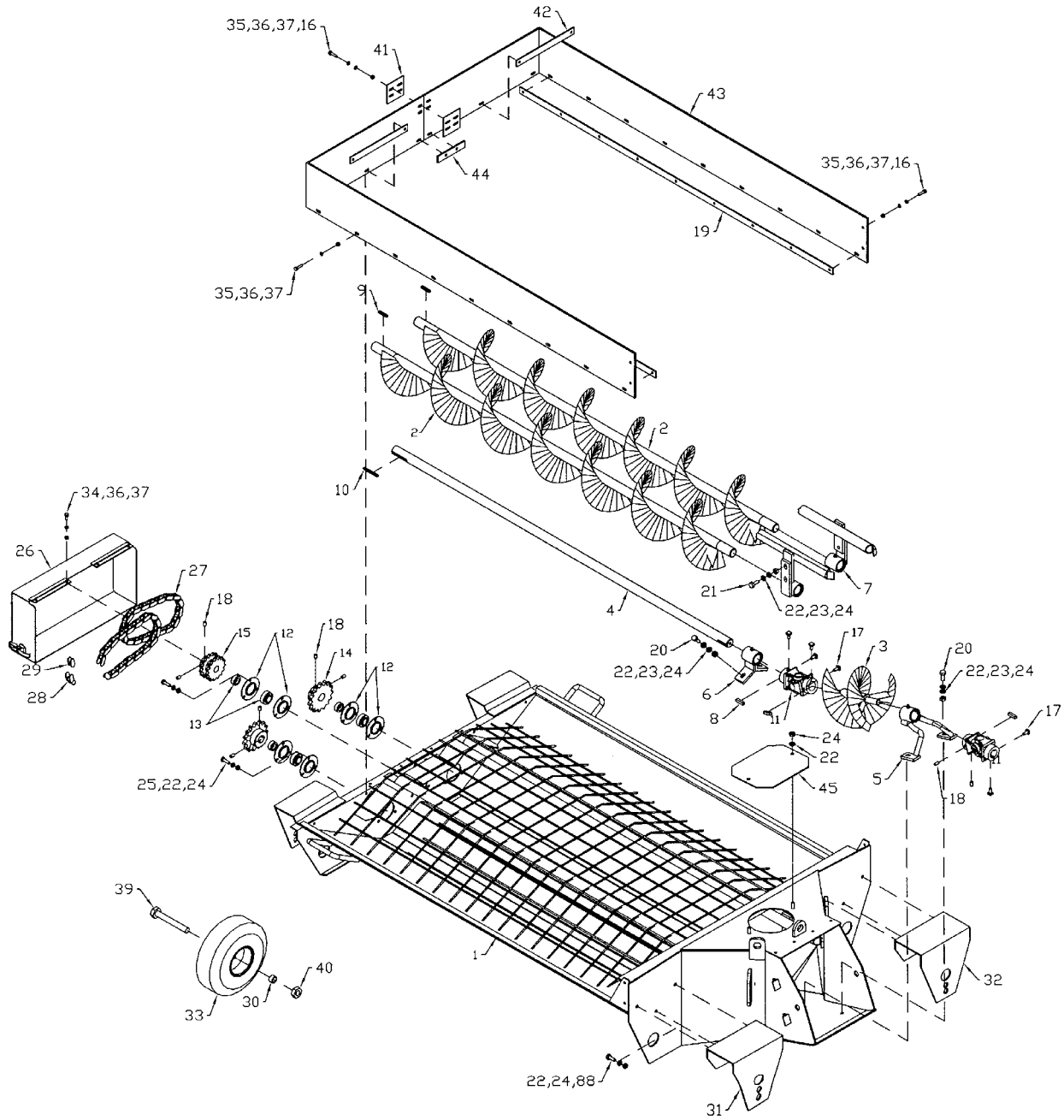

TF-06

10" MULTI-FLIGHTING HOPPER

Item #	Part #	Description
1	909916	Hopper
2	909908	Outside Flighting

3	905352	Center Flighting
4	909901	Center Flighting Shaft
5	905840	Center Flighting Holder
6	905842	Center Shaft Holder
7	905844	Outside Flighting Holder
8	960180	Hopper U-Joint Keys 5/16" x 1 3/8"
9	963026	Outside Sprocket Key 1/4" x 1 1/2"
10	905369	Inside Sprocket Key 1/4" x 2 1/2"
11	960547	U-Joint 1 1/4" Both Ends with 5/16" Keyway
12	961637	Flange Bearing (62MS) Pair
13	965818	1 1/4" Bearing with Collar
14	960492	Sprocket 17T #60 1 1/4" Bore
15	905562	Sprocket 14T #60 1 1/4" Bore
16	81546	1/4" B.S. Flat Washer
17	812037	3/8" x 3/4" Setscrew Square Head
18	812490	3/8" x 3/8" Setscrew Socket Ser
19	960660	Rubber Reinforcement 1" x 57 1/4"
20	86171	3/8" x 1 1/4" Hex Bolt
21	811792	3/8" x 1 1/2" Hex Bolt
22	81593	3/8" Lock Washer
23	84000	3/8" Flat Washer
24	81592	3/8" Hex Nut
25	86170	3/8" x 1" Hex Bolt
26	904584	Chain Guard
27	906480	Chain Assy #60H x 31L Including Connector & Offset
28	912300199	Connector Link #60
29	912300198	Chain #60 Offset Link
30	960839	Spacer 1" O.D. x 1 1/2"
31	905365	Standard Wheel Bracket 9" x 17 7/8" x 7 Ga - Left
32	905366	Standard Wheel Bracket 9" x 17 7/8" x 7 Ga - Right
33	960714	Wheel with Tire 4.10/3.50
34	81525	1/4" x 3/4" Hex Bolt
35	81527	1/4" x 1" Hex Bolt
36	81701	1/4" Lock Washer
37	81544	1/4" Hex Nut
38	86170	3/8" x 1" Hex Bolt
39	812114	3/4" x 5 1/2" Hex Bolt
40	812365	3/4" Lock Nut
41	903483	3" x 3" x 14 Ga Connector Plates
42	960837	1" x 10 1/2" x 10 Ga Rubber Reinforcement
43	905608	1/4" x 7" x 81" Rubber Strips with Holes
44	960834	3/16" x 1" x 5" Long Rubber Reinforcement
45	905364	Top Cover 7 1/2" x 9 1/2"

10" x 10' Extension Parts List

Item #	Part #	Description
1	960401	10" x 10' Tube
2	960402	10" x 10' Flighting
3	960018	Upper Bridging Yoke (31 1/2")
4	960403	Center Bridging Yoke (69")
5	960404	Center Bridging Tie Rod (26 3/4")
6	960405	Main Bridging Yoke (64")
7	960608	Main Bridging Brace (43 1/2")
8	960406	1/2" x 31'-9" Cable Assembled
	960407	1/2" x 33'-5" Cable Only
9	960408	1/2" x 64'-10" Cable Assembled
	960409	1/2" x 66'-6" Cable Only
10	84277	1/2" x 1 1/2" Hex Bolt
11	81637	1/2" Lock Washer
12	81636	1/2" Hex Nut
13	81598	7/16" x 1 1/4" Hex Bolt
14	81615	7/16" Lock Washer
15	81614	7/16" Hex Nut
16	964565	1/2" Cable Clamp
17	964001	3/8" Flat Washer (10 Ga)
18	811792	3/8" x 1 1/2" Hex Bolt
19	81593	3/8" Lock Washer
20	81592	3/8" Hex Nut
21	81620	1/2" x 1 1/4" Hex Bolt
22	9812368	1/2" x 2 3/4" (Gr.8) Hex Bolt
23	812364	1/2" Lock Nut

3.50 Dia. x 30.00 - CYLINDER ASSEMBLY

Item #	Part #	Description
	F9183	Cylinder Complete
1	24676	3.50 Dia. Head plate
2	108143	1.50 Dia. X 36.75 Lg Shaft Weldment
3	24883	3.50 Dia. Tube Weldment
4	105398	3.50 Dia. Piston
5	813407	Locknut 1.0 Unf
6	82338	O Ring 3.125 ID x 3.50 OD x 0.19
7	83338	Backup 3.125 ID x 3.50 OD x 0.06
8	82020	O Ring 0.875 ID x 1.00 ID x 0.06
9	810811	U-Cup 1.50 ID x 2.125 OD x 0.313
10	812976	Wiper Seal 1.50 ID x 1.875 OD (Snap-In)
11	812081	Plug 3/4" MORB Steel
12	22370	Hydraulic Cylinder Decal
13	105420	Reference Plate JBI/FK Serial #

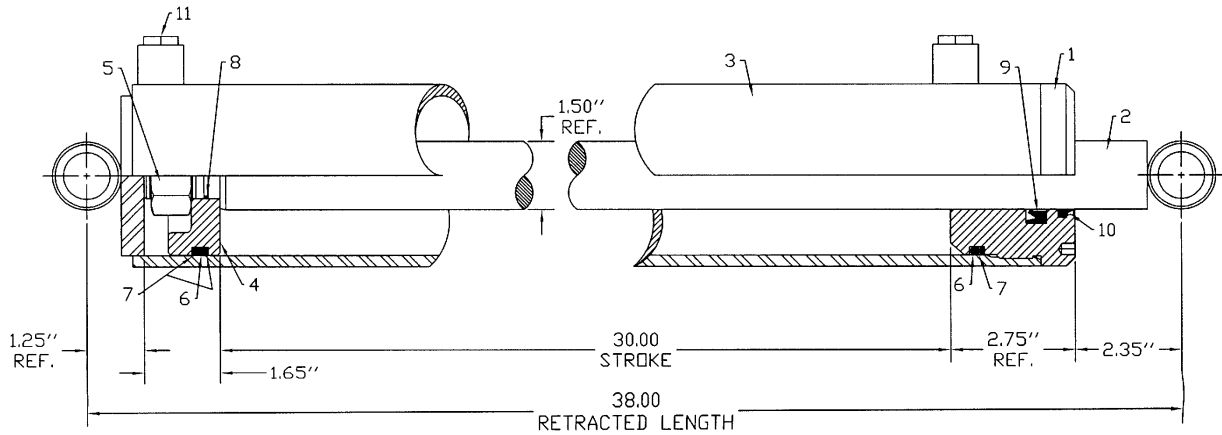

TF-19

4.00 Dia. x 36.00 - CYLINDER ASSEMBLY

Item #	Part #	Description
	F9184	Cylinder Complete
1	24865	4.0 Dia. Head plate
2	105422	Shaft Weld't 2.00 OD x 43.75 Lg
3	24884	4.0 Dia. Tube Weldment
4	105152	4.0 Dia. Piston
5	813407	Locknut 1.0 UNF
6	82342	O-Ring 3.625 ID x 4.0 x 0.19
7	83342	Backup 3.625 ID x 4.0 OD x 0.06
8	82020	O-Ring -.875 ID x 1.00 x 0.06
9	812967	U-Cup 2.00 ID x 2.50 OD x 0.375
10	812978	Wiper Seal 2.00 ID x 2.50 OD (Snap-In)
11	812081	Plug 3/4" MORB Steel
12	22370	Hydraulic Cylinder Decal
13	105420	Reference Plate JBI/FK Serial #

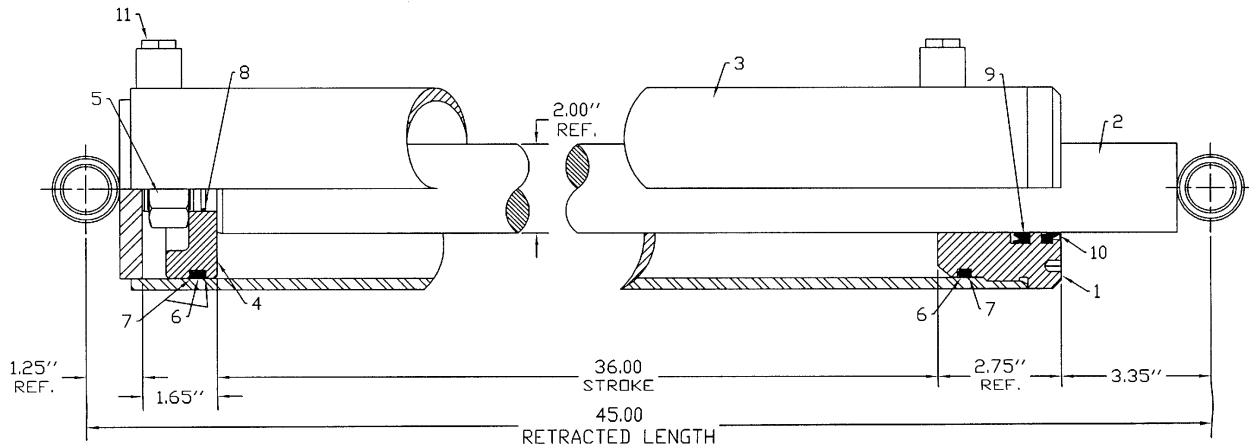

TF-20

4.0 Dia. x 40.00 - CYLINDER ASSEMBLY

Item #	Part #	Description
	F9185	Cylinder Complete
1	24865	4.0 Dia. Head plate
2	105426	Shaft Weld't 2.0 OD x 47.50 Lg
3	24885	4.0 Dia. Tube Weldment
4	105152	4.0 Dia. Piston
5	813407	Locknut 1.0 UNF
6	82342	O-Ring 3.625 ID x 4.0 OD x 0.19
7	83342	Backup 3.625 ID x 4.0 OD x 0.06
8	82020	O-Ring 0.875 ID x 1.00 x 0.06
9	812967	U-Cup 2.00 ID x 2.50 OD x 0.375
10	812978	Wiper Seal 2.00 ID x 2.50 OD (Snap In)
11	812081	Plug 3/4" MORB Steel
12	22370	Hydraulic Cylinder Decal
13	105420	Reference Plate JBI/FK Serial #

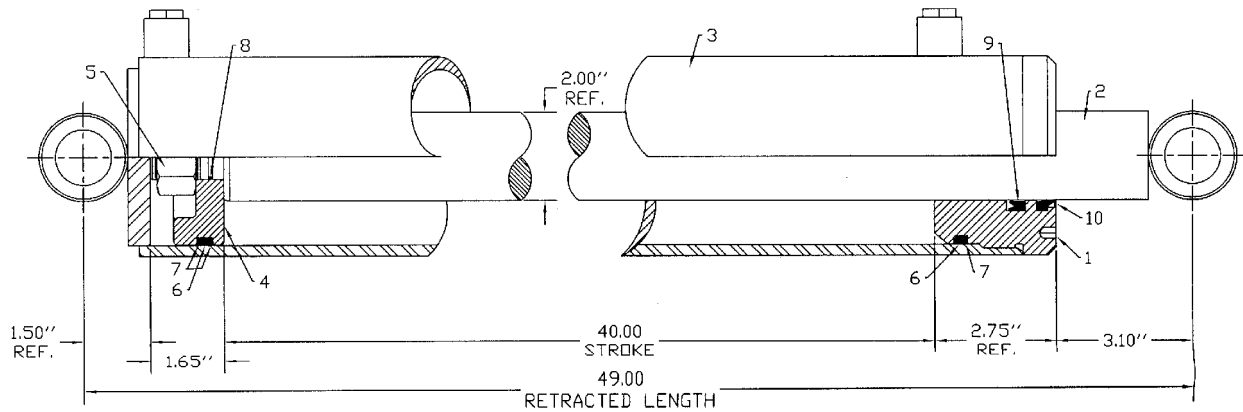

TF-21

10" BACKSAVER AUGER PTO SHAFT

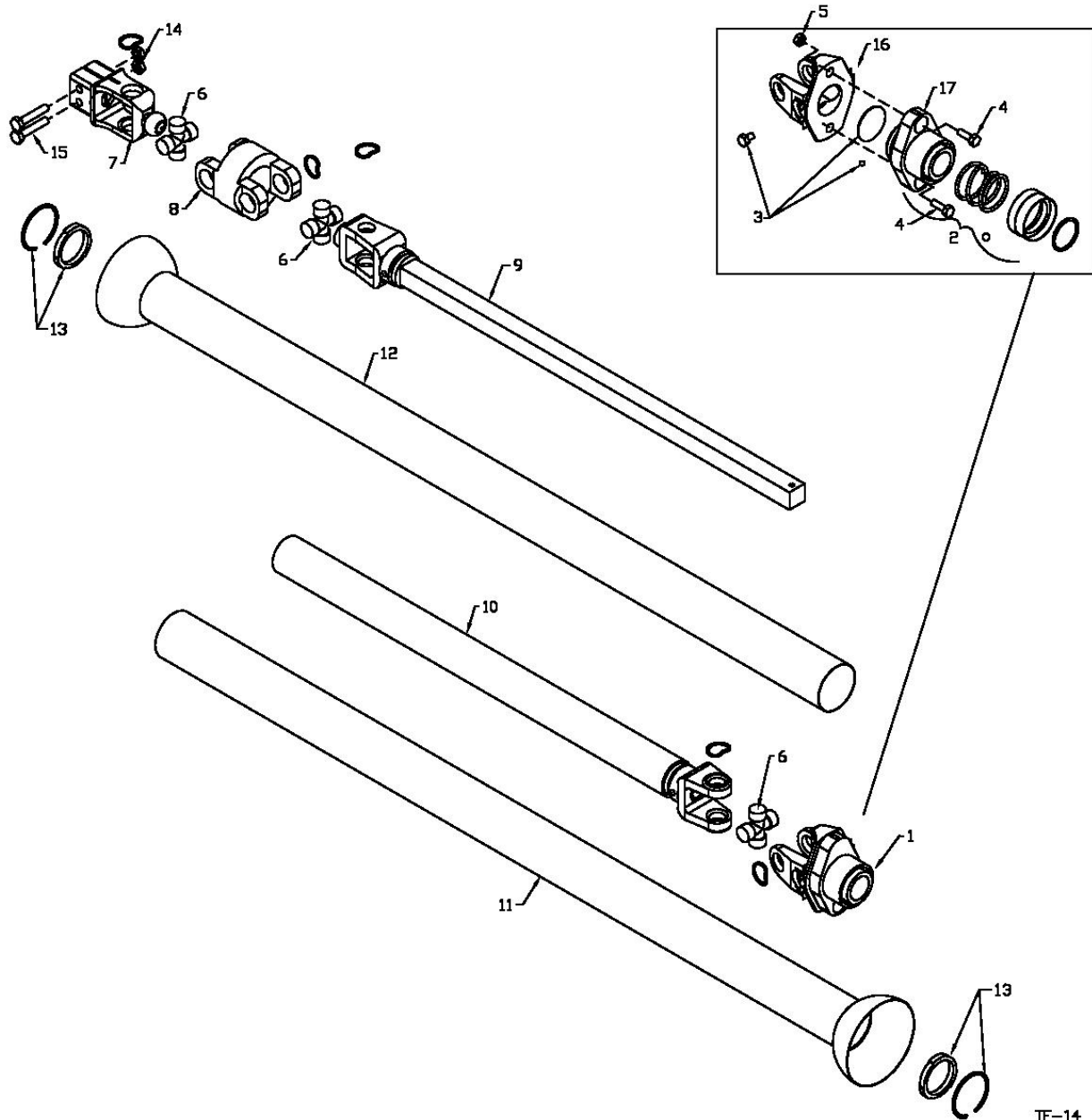

TF-14

10" BACKSAVER AUGER PTO SHAFT PARTS LIST

Item #	Part #	Description
	F9042	Shaft Complete
	936166	Inner Half Shaft - Tractor (with Shear)
	936317	Outer Half Shaft - Implement (with CV)
1	936167	Ball Shear Assembly
2	936168	Spring Lock Repair Kit (Ret. Ring, Collar, Spring 2-3/8" Balls)
3	936248	Shear Assembly Repair Kit (3/8" x 1/2" Bolt, Blank, 24-1/4" Balls)
4	903296	Shear bolt - 5/16" x 1" (Gr. 5) (Pack of 10)
5	812362	5/16" Lock Nut
6	906503	Repair Kit - Extended Life (standard)
	936093	Repair Kit - Optional
7	936318	Clamp Yoke
8	936181	CV Centre Housing
9	936180	Yoke & Shaft
10	936173	Yoke & Tube
11	936176	Inner Guard
12	936178	Outer Guard
13	936319	Nylon Repair Kit (Bearing & Snap Ring)
14	812364	1/2" Lock Nut
15	81627	1/2" x 3" Cap Screw
16	936172	Shear Flange Yoke
17	936169	Shear Flange Hub

REVERSE OPTION PTO SHAFT

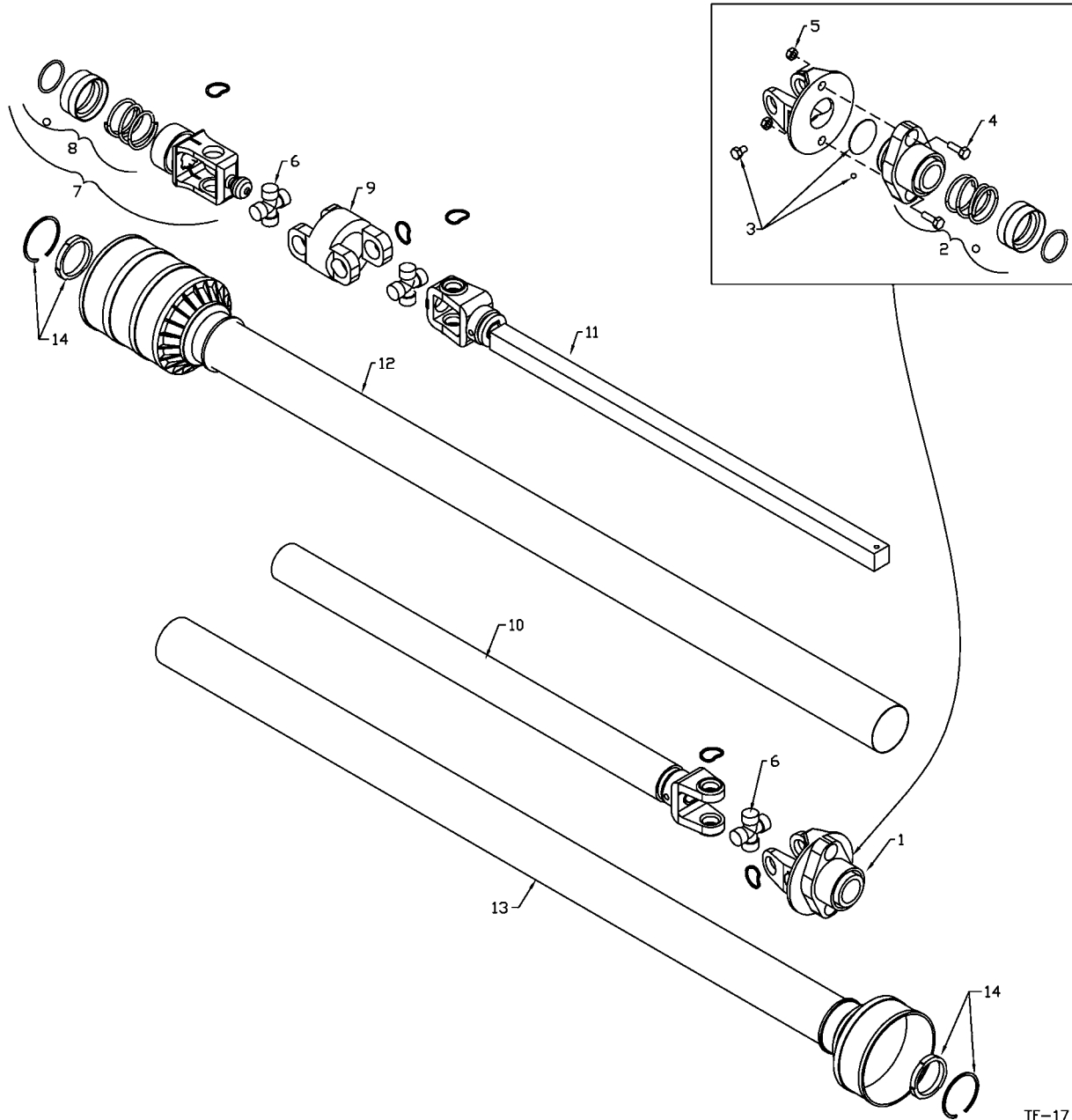

TF-17

10" BACKSAVER AUGER REVERSE OPTION PTO SHAFT PARTS LIST

Item #	Part #	Description
	F9043	Shaft Complete
	908718	Outer Half Shaft - Implement
	936166	Inner Half Shaft - Tractor
1	936167	Ball Shear Assembly
2	936168	Safety Slide Lock Repair Kit (collar, spring, ret. Ring, 2-pawls)
3	936248	Shear Assembly Repair Kit (3/8" x 1/2" bolt, lube, blank, 31-1/4" balls)
4	903296	Bag of 10 - Shear Bolts - 5/16" x 1" (gr. 5) with Nuts
5	812362	5/16" Lock Nut
6	906503	Repair Kit - Extended Life (standard)
	936093	Repair Kit - Optional
7	936218	Outer Spline Yoke
8	936226	Safety Slide Lock Repair Kit
9	936181	CV Center Housing
10	936173	Yoke & Tube
11	936180	Yoke & Shaft
12	936178	Outer Shield
13	936176	Inner Guard
14	936319	Nylon Repair Kit 20 x 26 (bearing & snap ring)

10" MECHANICAL DRIVE – INPUT BOX GEARBOX

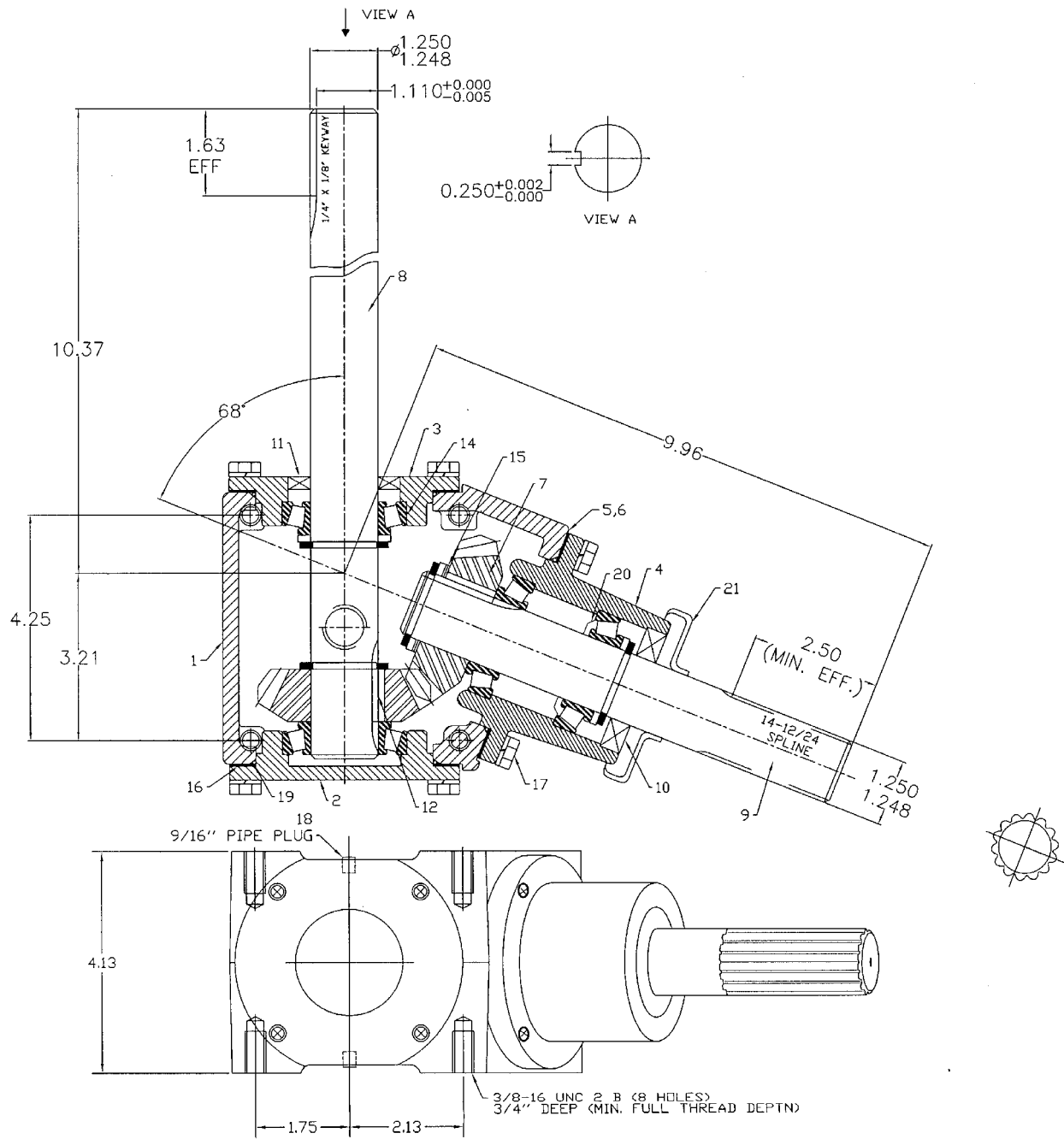

TF-15

10" BACKSAVER AUGER - INPUT BOX GEARBOX

Item #	Part #	Description
	960953	Gearbox Complete
1	960496	Case
2	960802	End Cap
3	960498	End Cap
4	960497	Quill
5	967712	Bearing Cone LM67048
6	967711	Bearing Cup LM67010
7	960505	Gear, DP 6 Teeth 19
8	960512	Shaft, Cross
9	960955	Shaft, Quill 14T
10	960509	Seal, (1.25x2.374x0.315)
11	960510	Seal, (1.25x2.00x0.315)
12	960513	Square Key, 1/4" x 0.9"
13	966769	Snap Ring
14	9812442	Spacer
15	960504	Spacer
16	93009	Gasket
17	9812351	Cap screw, 5/16" - 18UNC x 3/4"
18	960818	9/16" Pipe Plug w/ O-Ring
19	906444	O-Ring, 71mm x 1.8
20	960514	Grease Washer
21	960747	Shield

10" MECHANICAL DRIVE – INTAKE AUGER GEARBOX

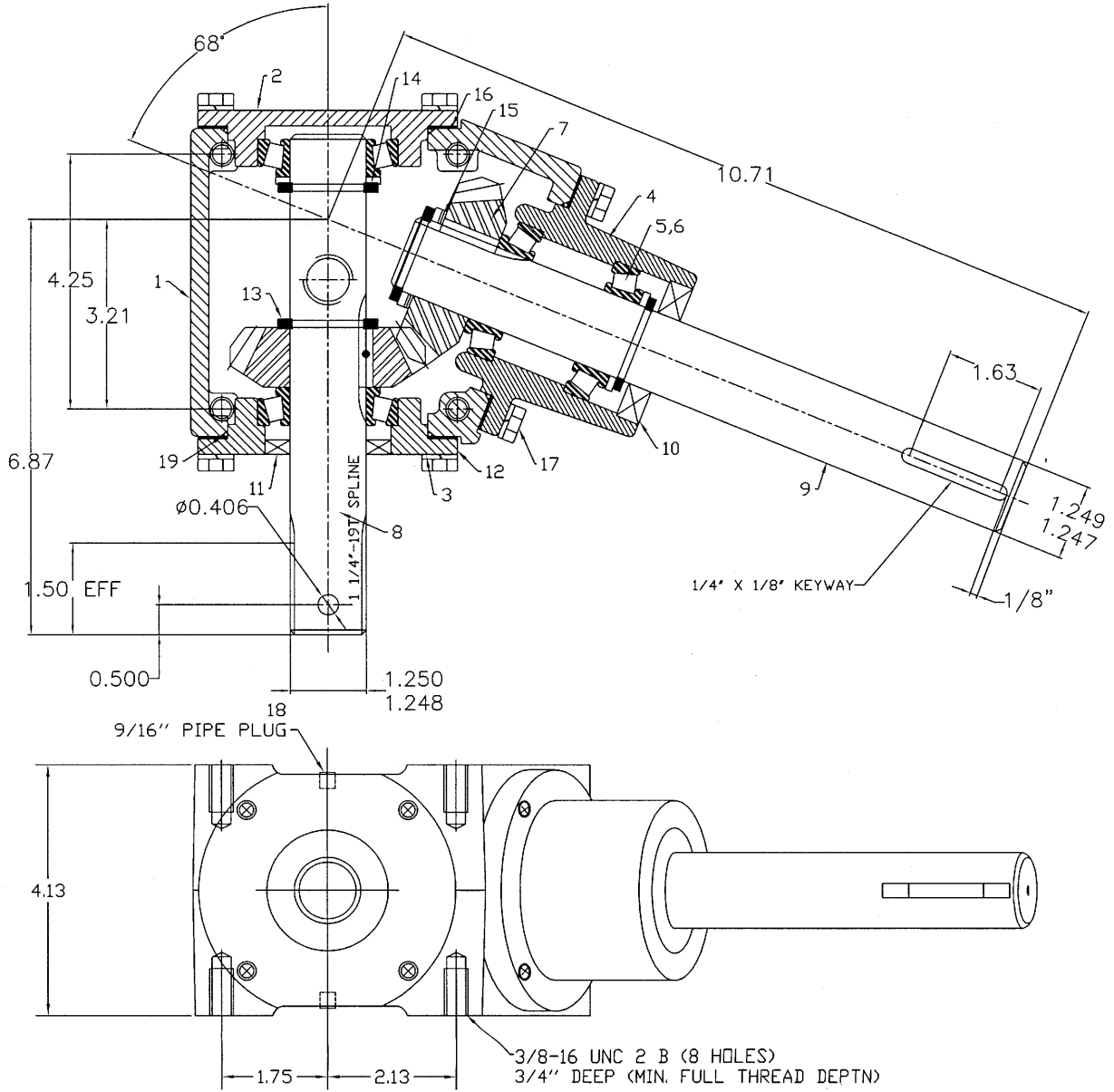

TF-16

10" BACKSAVER AUGER - INTAKE AUGER GEARBOX

Item #	Part #	Description
	960952	Gearbox Complete
1	960496	Case
2	960802	End Cap
3	960498	End Cap
4	960497	Quill
5	967712	Bearing Cone LM67048
6	967711	Bearing Cup LM67010
7	960505	Gear, DP 6 Teeth 19
8	960944	Shaft, Cross
9	960954	Shaft, Quill
10	960509	Seal, (1.25x2.374x0.315)
11	960510	Seal, (1.25x2.00x0.315)
12	960513	Square Key, 1/4" x 0.9"
13	966769	Snap Ring
14	9812442	Spacer
15	960504	Spacer
16	93009	Gasket
17	9812351	Capscrew, 5/16"-18UNCx3/4"
18	960818	9/16" Pipe Plug w/ O-Ring
19	906444	O-Ring, 71mm x 1.8

1051 WINCH - #960150

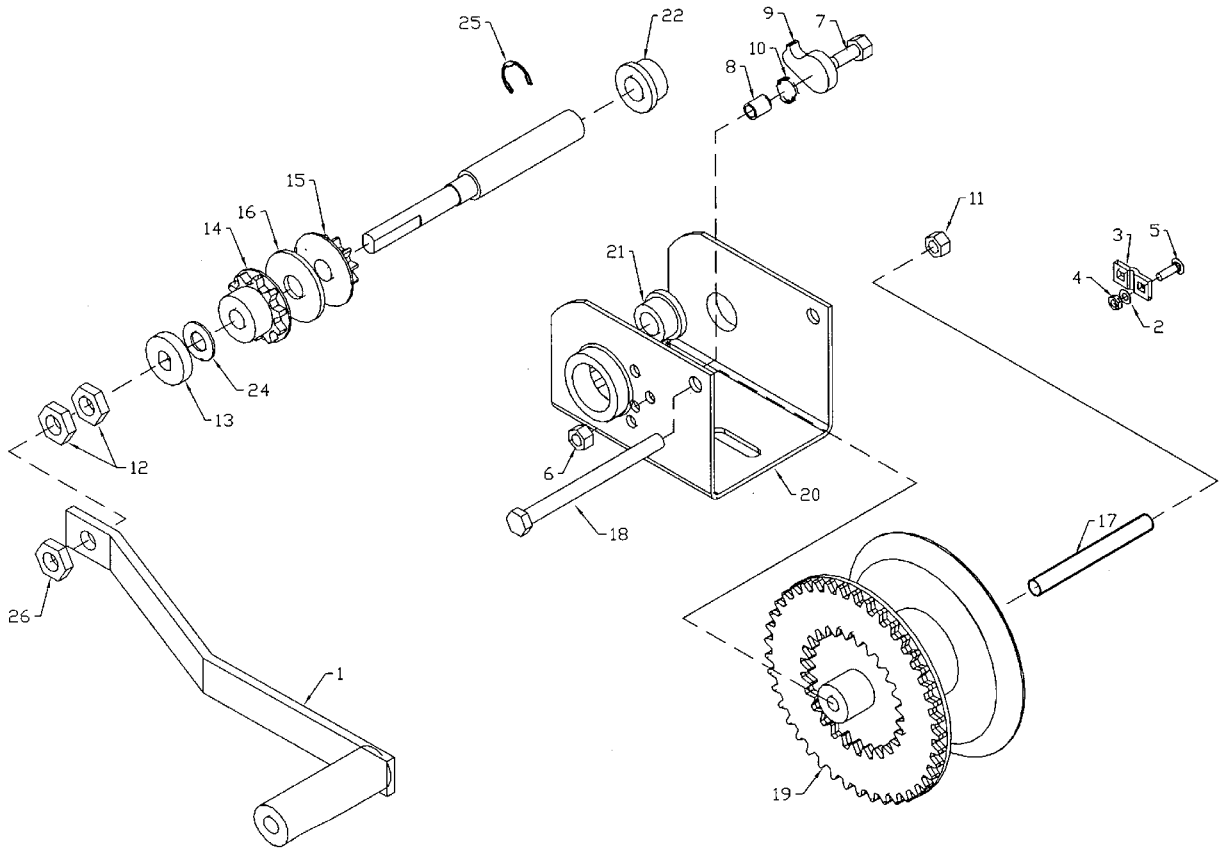

TF--22

No. 1051 WINCH PARTS LIST - 960150

Item #	Part #	Description
1	2461S01	Handle Assembly
2	5621S01	CABLE KEEPER KIT
3		Lockwasher #10
4		Cable Clamp
5		Nut - #10-24, Hex
		Carriage Bolt #10-24 x .69Lg
6	6731S00	RATCHET KIT
7		Lock Nut - 5/16-18
8		Hex Bolt - 5/16-18 x 1.00 Lg Gr.5
9		Ratchet Spacer
10		Ratchet Pawl
		Ratchet Spring
11	*	Lock Nut - 3/8-16
12	*	Lock Nut - 1/2-13
13	*	Disc - Brake
14	*	Ratchet Assembly
15	*	Pinion Gear Assembly
16	*	Friction Disc
17	*	Spacer - Drum, 3.81 Lg
18	*	Hex Bolt - 3/8-16 x 4.50 Lg Gr.2
19	*	Drum Weldment
20	*	Frame - K1051
21	*	Bushing - 1.25 ID x .50 Lg
22	*	Bushing - .758 ID x .50 Lg
23	*	Pinion Shaft
24	*	Nylon Washer
25	*	Retaining Ring - 3/4
26		Lock Nut - 1/2-13, Nylon
		* Not Available

SHIPPING KIT AND BUNDLE NUMBERS

The following is a list of Kit Numbers for this product and the Bundle Numbers, Descriptions, and Quantities for each Kit.

QUANTITY BUNDLE NO. DESCRIPTION

Y1050TM 10" x 50' BACKSAVER AUGER

1 only	F9070	Top Section, 10" x 50'
1 only	F0205	Bottom Section, 10" x 50'
1 only	F0171	Axle, 10" x 50'
1 only	F9253	Right Arm, 10" x 50'
1 only	F9252	Left Arm, 10" x 50'
1 only	F9021	Upper Lift Arm, 10" x 50'
1 only	F9024	Lower Lift Arm, 10" x 50'
1 only	F0101	Intake Auger
1 only	F0907	Intake Hopper
1 only	F9042	PTO Shaft
1 only	F0931	Crate of Parts
1 only	F0919	Input Box
2 only	F0110	15" x 5" x 5 Bolt Wheels Only
1 only	F0908	Carton of Parts

Y1050TMR 10" x 50' BACKSAVER AUGER W/REVERSE KIT

1 only	F9070	Top Section, 10" x 50'
1 only	F0205	Bottom Section, 10" x 50'
1 only	F0171	Axle, 10" x 50'
1 only	F9253	Right Arm, 10" x 50'
1 only	F9252	Left Arm, 10" x 50'
1 only	F9021	Upper Lift Arm, 10" x 50'
1 only	F9024	Lower Lift Arm, 10" x 50'
1 only	F0101	Intake Auger
1 only	F0907	Intake Hopper
1 only	F9043	PTO Shaft
1 only	F0931	Crate of Parts
1 only	F0920	Input Box
2 only	F0110	15" x 5" x 5 Bolt Wheels Only
1 only	F0908	Carton of Parts

Y1050TMM 10" x 50' BACKSAVER AUGER W/MULTI-FLIGHTING INTAKE HOPPER

1 only	F9070	Top Section, 10" x 50'
1 only	F0205	Bottom Section, 10" x 50'
1 only	F0171	Axle, 10" x 50'
1 only	F9253	Right Arm, 10" x 50'
1 only	F9252	Left Arm, 10" x 50'
1 only	F9021	Upper Lift Arm, 10" x 50'
1 only	F9024	Lower Lift Arm, 10" x 50'
1 only	F0101	Intake Auger
1 only	F0905	Multi-Flighting Hopper
1 only	F9042	PTO Shaft
1 only	F0931	Crate of Parts
1 only	F0919	Input Box
2 only	F0110	15" x 5" x 5 Bolt Wheels Only
1 only	F0906	Carton of Parts

Y1050TMMR 10" x 50' BACKSAVER AUGER W/MULTI-FLIGHTING INTAKE HOPPER AND REVERSE KIT

1 only	F9070	Top Section, 10" x 50'
1 only	F0205	Bottom Section, 10" x 50'
1 only	F0171	Axle, 10" x 50'
1 only	F9253	Right Arm, 10" x 50'
1 only	F9252	Left Arm, 10" x 50'
1 only	F9021	Upper Lift Arm, 10" x 50'
1 only	F9024	Lower Lift Arm, 10" x 50'
1 only	F0101	Intake Auger
1 only	F0905	Multi-Flighting Hopper
1 only	F9043	PTO Shaft
1 only	F0931	Crate of Parts
1 only	F0920	Input Box
2 only	F0110	15" x 5" x 5 Bolt Wheels Only
1 only	F0906	Carton of Parts

Y1060TM 10" x 60' BACKSAVER AUGER

1 only	F9071	Top Section, 10" x 60'
1 only	F9073	Center Section, 10" x 60'
1 only	F0206	Bottom Section, 10" x 60'
1 only	F0172	Axle, 10" x 60'
1 only	F9251	Right Arm, 10" x 60'
1 only	F9250	Left Arm, 10" x 60'
1 only	F9022	Upper Lift Arm, 10" x 60'
1 only	F9025	Lower Lift Arm, 10" x 60'
1 only	F0101	Intake Auger
1 only	F0907	Intake Hopper
1 only	F9042	PTO Shaft
1 only	F0932	Crate of Parts
1 only	F0919	Input Box
2 only	F0110	15" x 5" x 5" Bolt Wheels Only
1 only	F0908	Carton of Parts

Y1060TMR 10" x 60' BACKSAVER AUGER W/REVERSE KIT

1 only	F9071	Top Section, 10" x 60'
1 only	F9073	Center Section, 10" x 60'
1 only	F0206	Bottom Section, 10" x 60'
1 only	F0172	Axle, 10" x 60'
1 only	F9251	Right Arm, 10" x 60'
1 only	F9250	Left Arm, 10" x 60'
1 only	F9022	Upper Lift Arm, 10" x 60'
1 only	F9025	Lower Lift Arm, 10" x 60'
1 only	F0101	Intake Auger
1 only	F0907	Intake Hopper
1 only	F9043	PTO Shaft
1 only	F0932	Crate of Parts
1 only	F0920	Input Box
2 only	F0110	15" x 5" x 5" Bolt Wheels Only
1 only	F0908	Carton of Parts

Y1060TMM 10" x 60' BACKSAVER AUGER W/MULTI-FLIGHTING INTAKE HOPPER

1 only	F9071	Top Section, 10" x 60'
1 only	F9073	Center Section, 10" x 60'
1 only	F0206	Bottom Section, 10" x 60'
1 only	F0172	Axle, 10" x 60'
1 only	F9251	Right Arm, 10" x 60'
1 only	F9250	Left Arm, 10" x 60'
1 only	F9022	Upper Lift Arm, 10" x 60'
1 only	F9025	Lower Lift Arm, 10" x 60'
1 only	F0101	Intake Auger
1 only	F0905	Multi-Flighting Hopper
1 only	F9042	PTO Shaft
1 only	F0932	Crate of Parts
1 only	F0919	Input Box
2 only	F0110	15" x 5" x 5" Bolt Wheels Only
1 only	F0906	Carton of Parts

Y1060TMMR 10" x 60' BACKSAVER AUGER W/MULTI-FLIGHTING INTAKE HOPPER

AND REVERSE KIT

1 only	F9071	Top Section, 10" x 60'
1 only	F9073	Center Section, 10" x 60'
1 only	F0206	Bottom Section, 10" x 60'
1 only	F0172	Axle, 10" x 60'
1 only	F9251	Right Arm, 10" x 60'
1 only	F9250	Left Arm, 10" x 60'
1 only	F9022	Upper Lift Arm, 10" x 60'
1 only	F9025	Lower Lift Arm, 10" x 60'
1 only	F0101	Intake Auger
1 only	F0905	Multi-Flighting Hopper
1 only	F9043	PTO Shaft
1 only	F0932	Crate of Parts
1 only	F0920	Input Box
2 only	F0110	15" x 5" x 5" Bolt Wheels Only
1 only	F0906	Carton of Parts

Y1070TM 10" x 70' BACKSAVER AUGER

1 only	F9072	Top Section, 10" x 70'
1 only	F9074	Center Section, 10" x 70'
1 only	F0207	Bottom Section, 10" x 70'
1 only	F0173	Axle, 10" x 70'
1 only	F9249	Right Arm, 10" x 70'
1 only	F9248	Left Arm, 10" x 70'
1 only	F9023	Upper Lift Arm, 10" x 70'
1 only	F9026	Lower Lift Arm, 10" x 70'
1 only	F0101	Intake Auger
1 only	F0907	Intake Hopper
1 only	F9042	PTO Shaft
1 only	F0933	Crate of Parts
1 only	F0919	Input Box
2 only	F0110	15" x 5" x 5" Bolt Wheels Only
1 only	F0908	Carton of Parts

Y1070TMR 10" x 70' BACKSAVER AUGER W/REVERSE KIT

1 only	F9072	Top Section, 10" x 70'
1 only	F9074	Center Section, 10" x 70'
1 only	F0207	Bottom Section, 10" x 70'
1 only	F0173	Axle, 10" x 70'
1 only	F9249	Right Arm, 10" x 70'
1 only	F9248	Left Arm, 10" x 70'
1 only	F9023	Upper Lift Arm, 10" x 70'
1 only	F9026	Lower Lift Arm, 10" x 70'
1 only	F0101	Intake Auger
1 only	F0907	Intake Hopper
1 only	F9043	PTO Shaft
1 only	F0933	Crate of Parts
1 only	F0920	Input Box
2 only	F0110	15" x 5" x 5" Bolt Wheels Only
1 only	F0908	Carton of Parts

Y1070TMM 10" x 70' BACKSAVER AUGER W/MULTI-FLIGHTING HOPPER

1 only	F9072	Top Section, 10" x 70'
1 only	F9074	Center Section, 10" x 70'
1 only	F0207	Bottom Section, 10" x 70'
1 only	F0173	Axle, 10" x 70'
1 only	F9249	Right Arm, 10" x 70'
1 only	F9248	Left Arm, 10" x 70'
1 only	F9023	Upper Lift Arm, 10" x 70'
1 only	F9026	Lower Lift Arm, 10" x 70'
1 only	F0101	Intake Auger
1 only	F0905	Multi-Flighting Hopper
1 only	F9042	PTO Shaft
1 only	F0933	Crate of Parts
1 only	F0919	Input Box
2 only	F0110	15" x 5" x 5" Bolt Wheels Only
1 only	F0906	Carton of Parts

Y1070TMMR 10" x 70' BACKSAVER AUGER W/MULTI-FLIGHTING HOPPER AND REVERSE KIT

1 only	F9072	Top Section, 10" x 70'
1 only	F9074	Center Section, 10" x 70'
1 only	F0207	Bottom Section, 10" x 70'
1 only	F0173	Axle, 10" x 70'
1 only	F9249	Right Arm, 10" x 70'
1 only	F9248	Left Arm, 10" x 70'
1 only	F9023	Upper Lift Arm, 10" x 70'
1 only	F9026	Lower Lift Arm, 10" x 70'
1 only	F0101	Intake Auger
1 only	F0905	Multi-Flighting Hopper
1 only	F9043	PTO Shaft
1 only	F0933	Crate of Parts
1 only	F0920	Input Box
2 only	F0110	15" x 5" x 5" Bolt Wheels Only
1 only	F0906	Carton of Parts

OPTIONAL BUNDLE NUMBERS

The following is a list of options available for the Kits listed above.

F3004	10" Flexible Spout (Galvanized)
F214	10" Poly Spout (Oval)
Y208	Set of 2 7.60 x 15 x 4 ply tires (non-highway rated)
F7346	Reverse Kit
F9042	PTO Shaft
F9550	Extreme-use PTO shaft (high moisture corn, peas, beans)
F9043	PTO Shaft for Reverse Kit (2 – 6 spline ends)
F0331	CE Approved CV PTO Shaft
Y1105	Multi-flighting hopper conversion
Y1104	Hopper Mover (hydraulic)
909681	Closed Centre Hopper Mover Valve Kit
F0017	Safety Light Kit
F0420	Safety Chain Assembly
Y120	10" x 10' Extension Kit (for extending 10" x 70' only)
F0014	Reflective Safety Decal Kit
F0923	Clevis Hitch
Y1106	Hydraulic Winch Kit

NOTES

DIVISION LOCATIONS

Farm King Division
301 Mountain Street S.
Morden, MB R6M 1X7
Ph.: (204) 822-4467
Fax: (204) 822-6348

Allied/Inland Division
1260 Clarence Avenue
Winnipeg, MB R3T 1T2
Ph.: (204) 284-6100
Fax: (204) 477-2325

B.I.I. Division
1330 43rd Street N.W.
Fargo, ND 58102
Ph: (701) 282-7014
Fax: (701) 282-5865

U.S. WAREHOUSES

AR, West Memphis
(870) 732-3132

GA, Stone Mountain
(770) 908-9439

ID, Meridian
(208) 887-6006

IN, Clarksville
(812) 284-3376

KS, Wichita
(316) 265-9577

MN, Lakeville
(952) 469-5267

MT, Billings
(406) 248-7771

ND, Bismarck
(701) 223-1886

ND, Fargo
(701) 282-7003

NE, Blair
(402) 426-8211

OH, Youngstown
(330) 793-0862

OR, Beaverton
(503) 641-1865

SD, Huron
(605) 352-8616

TX, Houston
(713) 928-2632

UT, Salt Lake City
(801) 972-4321

WI, Portage
(608) 742-1370

CANADIAN WAREHOUSES

B.C., Abbotsford
(604) 864-2665

AB, Edmonton
(780) 962-6991

SK, Regina
(306) 781-2300

ON, Woodstock
(519) 539-0435

QC, Dorion
(450) 455-4840

OFFSHORE WAREHOUSES

Burando Hill
Katanning
W. Australia
011-618-98-214422

Chihuahua, Mexico
011-52-158-90306

John Kerr Equipment Ltd.
Wilcoxholm Farm
Linlithgow, W. Lothian
Scotland
011-441-506-842280

Skovde, Sweden
011-46-500-452651

Naestved, Denmark
011-45-557-29511

bühler

Buhler Manufacturing

**301 Mountain Street S.
Morden MB.
R6M 1X7
Ph.: (204) 822-4467
Fax: (204) 822-6348
www.buhler.com**